



HESTORE.HU

elektronikai alkatrész áruház

EN: This Datasheet is presented by the manufacturer.

Please visit our website for pricing and availability at www.hestore.hu.

Piezo Element

Customer	
Customer P/O	
BeStar Model Name	FT-27T-4.0A1
Product No.	161900
Issue No.	BS/TEY01.076A
Issue Date	04/01/16

Approval:

1. Technical Terms
2. Drawing
3. Characteristics



BESTAR ELECTRONICS INDUSTRY CO., LTD
TianAn Industry Park4/F, Site B ChangZhou New District
Tel:86-519-5103228
Fax:86-519-5131010
Http:www.be-star.com
E-Mail:bestarco@pub.cz.jsinfo.net

FT-27T-4.0A₁

1. Technical Terms:

Item	Unit	Specification
Resonant Frequency	K Hz	4.0± 0.5
Resonant Resistance	Ω	200max
Capacitance at 120Hz	nF	25± 30%
Input Voltage	V _{p-p}	30max
Operating Temperature	°C	-20-+70
Storage Temperature	°C	-30-+80

2. Drawing

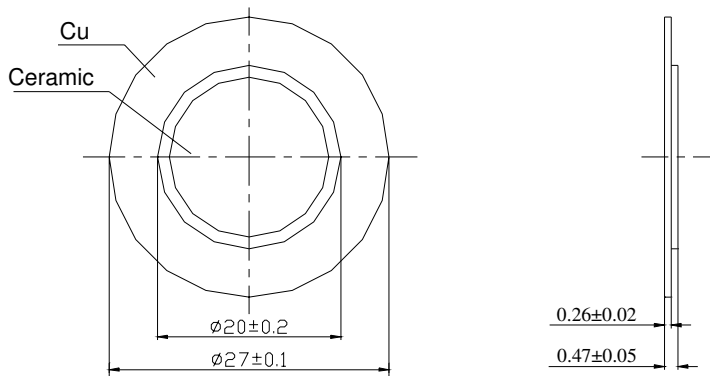

This print and information therein are proprietary to Bestar Electronics Industry Co., Ltd. and shall not be used in whole or in part without its written content

DIS.		DATE		Page:1 of 2 3rd angle projection	FT-27T-4.0A ₁
CHEC.		DATE			Piezo Element
APPR.		DATE			DRG NO BS/TEY01.076A
 BESTAR ELECTRONICS INDUSTRY CO.,LTD TianAn Industry Park 4/F, Site B ChangZhou New District					

FT-27T-4.0A₁

3.Characteristics:

3.1 Solderability

300±10°C Temperature of Merited Solder,2±0.5ec Duration of Dipping.

3.2 Lead pull off test

a) Wire to be soldered on ceramic at the edge. It should withstand minimum 1.5 kg force applied in 180°.The wire should not come out before this .The ceramic can be either glued on a surface of can be held in hand.(Fig.2)

b) Wire to be soldered on ceramic at the edge&should be pulled up at 90° The element should be hold on bottom and wire should be pulled up .It should withstand at least for 3000gm force(Fig.1)

3.3Bend Test

The element should be bend on to a pipe of 10mm diameter.The bend should be in only one direction. The length of pipeshould be at least 1.5 times the diameter of the brass disc.i.e for 20mm element ,the pipe should be at least 30mm .With this bend,ceramic cracking is allowed and chipping off of ceramic disc is not allowed

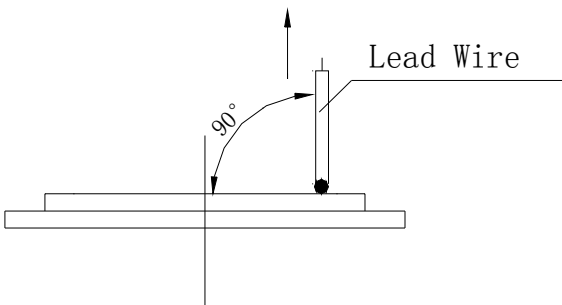

Fig.1 Direction of Lead Wire

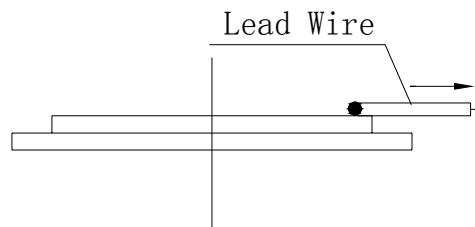

Fig.2 Direction of Lead Wire

This print and information therein are proprietary to Bestar Electronics Industry Co., Ltd. and shall not be used in whole or in part without its written content

DIS.		DATE		Page:2 of 2	FT-27T-4.0A ₁
CHEC.		DATE		3rd angle projection	
APPR.		DATE			Piezo Element
 BESTAR ELECTRONICS INDUSTRY CO.,LTD TianAn Industry Park 4/F,Site B ChangZhou New District					DRG NO BS/TEY01.076A