



HESTORE.HU

elektronikai alkatrész áruház

EN: This Datasheet is presented by the manufacturer.

Please visit our website for pricing and availability at www.hestore.hu.



PL-2303 Edition USB to Serial Bridge Controller Product Datasheet

Document Revision: 1.6

Document Release: April 26, 2005

Prolific Technology Inc.

7F, No. 48, Sec. 3, Nan Kang Rd.

Nan Kang, Taipei 115, Taiwan, R.O.C.

Telephone: + 886-2-2654-6363

Fax: + 886-2-2654-6161

E-mail: sales@prolific.com.tw

Website: <http://www.prolific.com.tw>



Disclaimer

All the information in this document is subject to change without prior notice. Prolific Technology Inc. does not make any representations or any warranties (implied or otherwise) regarding the accuracy and completeness of this document and shall in no event be liable for any loss of profit or any other commercial damage, including but not limited to special, incidental, consequential, or other damages.

Trademarks

The Prolific logo is a registered trademark of Prolific Technology Inc. All brand names and product names used in this document are trademarks or registered trademarks of their respective holders.

Copyrights

Copyright © 2005 Prolific Technology Inc. All rights reserved.

No part of this document may be reproduced or transmitted in any form by any means without the express written permission of Prolific Technology Inc.

Revision History

Revision	Description	Date
1.6	➤ Modify Temperature Characteristics (Sec 8.4)	April 26, 2005
1.5	<ul style="list-style-type: none"> ➤ Added List of Figures and List of Tables ➤ Modify Features section ➤ Improve clarity of Pin Assignment diagram ➤ Correct Minimum Operating Temperature to 0°C ➤ Modify Operating Voltage ➤ Add EEPROM Timing Diagram ➤ Add Reset Timing Diagram ➤ Added Ordering Information ➤ Added Reel Packing Information 	February 02, 2005
1.4	➤ Add Windows CE .NET support feature	August 29, 2002
1.3	➤ Buffer for upstream and downstream data flow – change from 96 to 256 bytes	August 01, 2002
1.2	<ul style="list-style-type: none"> ➤ For Chip Version H (date code 0206) ➤ Add OS Support in Features Section ➤ Correct default values in Table 5. Device Configuration Register ➤ Add Suspend Current in DC Characteristics Section ➤ Move Operating Temperature in DC Characteristics to new section 	July 03, 2002

Table of Contents

1.0	FEATURES.....	6
2.0	INTRODUCTION	6
3.0	FUNCTIONAL BLOCK DIAGRAM.....	7
4.0	PIN ASSIGNMENT OUTLINE	8
5.0	PIN ASSIGNMENT & DESCRIPTION.....	9
6.0	DATA FORMATS & PROGRAMMABLE BAUD RATE GENERATOR.....	10
7.0	EXTERNAL EEPROM AND DEVICE CONFIGURATION	11
8.0	ELECTRICAL, TEMPERATURE & TIMING CHARACTERISTICS.....	13
8.1	Absolute Maximum Ratings	13
8.2	DC Characteristics	13
8.3	Clock Characteristics	13
8.4	Temperature Characteristics	14
8.5	USB Transceiver Characteristics	14
8.6	EEPROM Timing Diagram	14
8.7	Reset Timing Diagram	15
9.0	OUTLINE DIAGRAM.....	16
9.1	SSOP28 Package.....	16
10.0	REEL PACKING INFORMATION.....	17
10.1	Carrier Tape (SSOP-28).....	17
10.2	Reel Dimension	18
11.0	ORDERING INFORMATION	18

List of Figures

Figure 3-1 Block Diagram of PL-2303.....	7
Figure 4-1 Pin Assignment Outline of PL-2303.....	8
Figure 8-1 Byte Write Timing Diagram.....	14
Figure 8-2 Selective Read Timing Diagram.....	15
Figure 8-3 Reset Timing Diagram.....	15
Figure 9-1 Outline Diagram of PL-2303 SSOP28.....	16
Figure 10-1a SSOP28 Carrier Tape.....	17
Figure 10-1b IC Reel Placements.....	17
Figure 10-2 Reel Dimension.....	18

List of Tables

Table 5-1 Pin Assignment & Description.....	9
Table 6-1 Supported Data Formats.....	10
Table 6-2 Baud Rate Setting.....	10
Table 7-1 EEPROM Contents.....	11
Table 7-2 Device Configuration Register.....	11
Table 8-1 Absolute Maximum Ratings.....	13
Table 8-2 DC Characteristics.....	13
Table 8-3 Clock Characteristics.....	13
Table 8-4 Temperature Characteristics.....	14
Table 8-5 USB Transceiver Characteristics.....	14
Table 8-6 Power-On Reset.....	15
Table 9-1 Package Dimension.....	16
Table 10-2 Reel Part Number Information.....	18
Table 11-1 Ordering Information.....	18

1.0 Features

- Fully compliant with USB Specification v1.1 and USB CDC v1.1
- Supports RS232 Serial interface
- Supports automatic handshake mode
- Supports Remote wake-up and power management
- 256-bytes buffer each for upstream and downstream data flow
- Supports default ROM or external EEPROM for device configuration
- On-chip USB transceiver
- On-chip crystal oscillator running at 12MHz
- Supports Windows 98/SE, ME, 2000, XP, Windows CE3.0, CE .NET, Linux, and Mac OS
- Designed for Windows XP/2000 Certified Logo Drivers
- USB-IF Logo Compliant with TID 10240590
- 28-Pin SSOP package

2.0 Introduction

The PL-2303 operates as a bridge between one USB port and one standard RS232 Serial port. The two large on-chip buffers accommodate data flow from two different buses. The USB bulk-type data is adopted for maximum data transfer. Automatic handshake is supported at the Serial port. With these, a much higher baud rate can be achieved compared to the legacy UART controller.

This device is also compliant with USB power management and remote wakeup scheme. Only minimum power is consumed from the host during Suspend. By integrating all the function in a SSOP-28 package, this chip is suitable for cable embedding. Users just simply hook the cable into PC or hub's USB port, and then they can connect to any RS-232 devices.

3.0 Functional Block Diagram

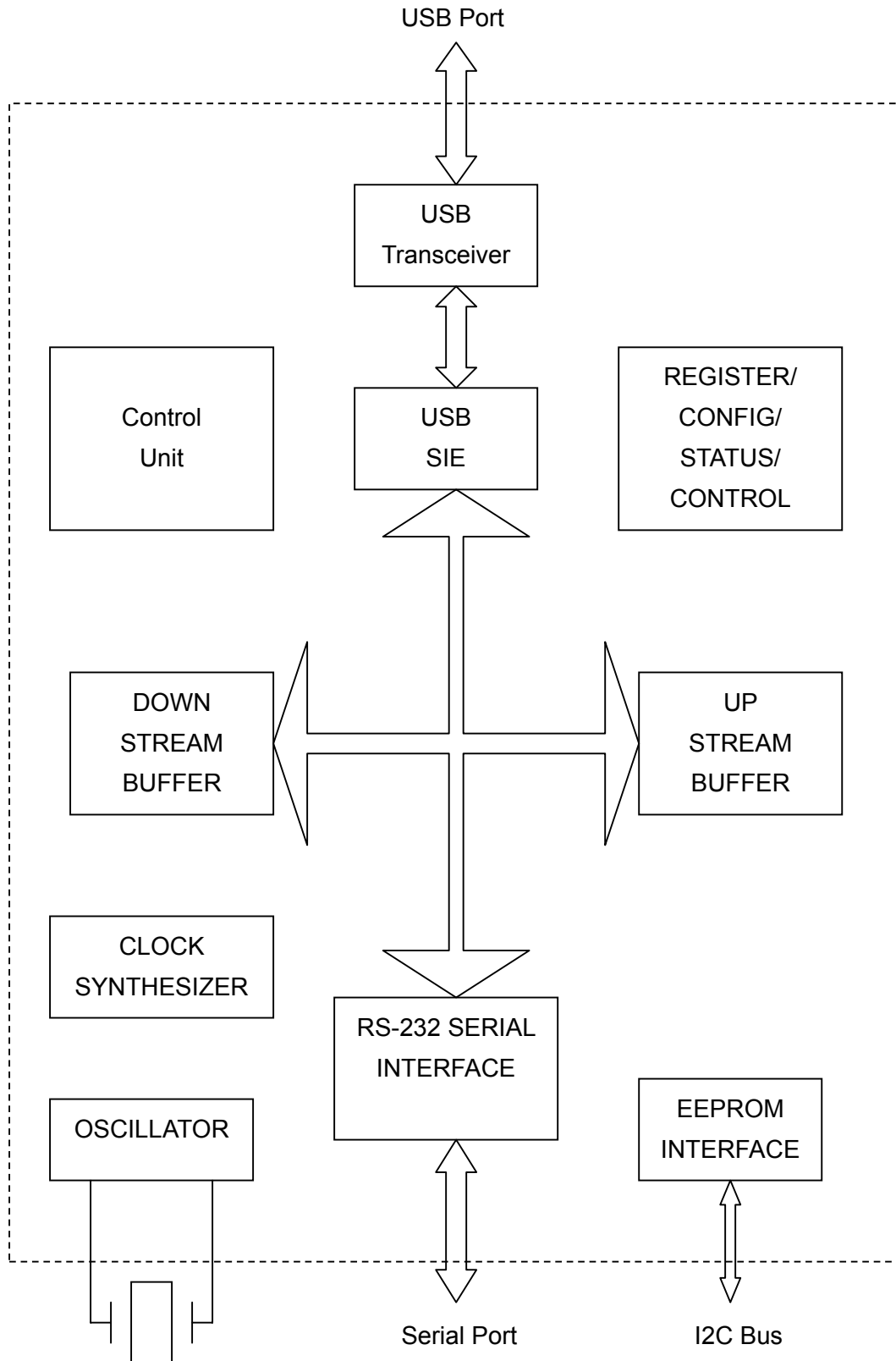

Figure 3-1 Block Diagram of PL-2303

4.0 Pin Assignment Outline

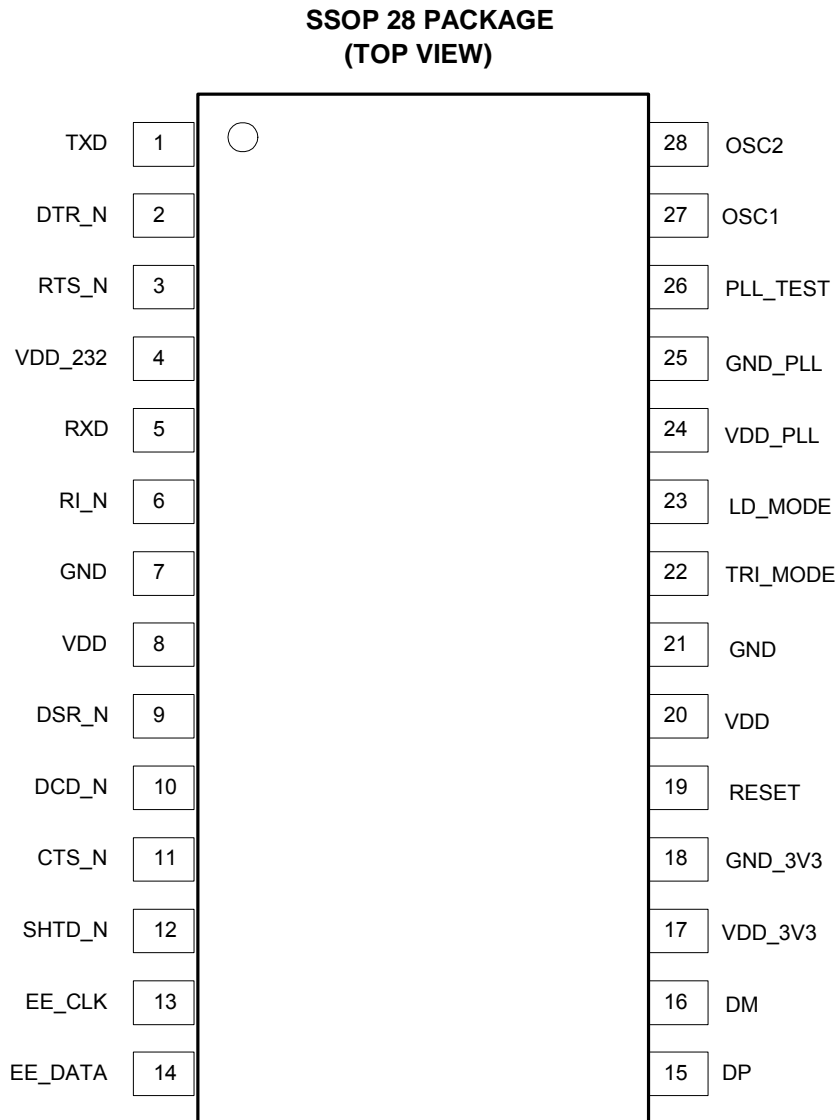

Figure 4-1 Pin Assignment Outline of PL-2303

5.0 Pin Assignment & Description

Table 5-1 Pin Assignment & Description

Pin No.	Name	Type	Description
1	TXD	O	Data output to Serial port
2	DTR_N	O	Data Terminal Ready, active low
3	RTS_N	O	Request To Send, active low
4	VDD_232	P	RS-232 VDD. The RS-232 output signals (Pin 1 ~ Pin 3) are designed for 5V, 3.3V or 3V operation. VDD_232 should be connected to the same power level of the RS-232 interface. (The RS-232 input signals are always 5V~3V tolerant.) Note: This document version only provides 5V DC characteristic information. Refer to future revisions for updates.
5	RXD	I	Data input from Serial Bus
6	RI_N	I	Ring Indicator, active low
7	GND	P	Ground
8	VDD	P	Power
9	DSR_N	I	Data Set Ready, active low
10	DCD_N	I	Data Carrier Detect, active low
11	CTS_N	I	Clear To Send, active low
12	SHTD_N	O	Shut Down RS232 Transceiver
13	EE_CLK	I/O	During Reset, this pin is input for simulation purpose. During normal operation, this pin is Serial ROM clock
14	EE_DATA	I/O	Serial ROM data signal
15	DP	I/O	USB DPLUS signal
16	DM	I/O	USB DMINUS signal
17	VDD_3V3	P	3.3V power for USB transceiver
18	GND_3V3	P	3.3V ground
19	RESET	I	System Reset
20	VDD	P	Power
21	GND	P	Ground
22	TRI_STATE	I	Tri-State This pin is referred after reset. High: RS-232 output inactive during Suspend. Low: RS-232 output tri-state during Suspend.
23	LD_MD/ SHTD	I/O	Load Mode/SHTD This pin is input during reset. Pull high with a 220K resistor to indicate the heavy load USB device (500mA). Pull down with a 220K resistor to indicate the light load USB device 100mA). After reset, this pin becomes output. It output the inverse of SHTD_N.
24	VDD_PLL	P	5V power for PLL
25	GND_PLL	P	Ground for PLL
26	PLL_TEST	I	PLL test mode control
27	OSC1	I	Crystal oscillator input
28	OSC2	O	Crystal oscillator output

Type: I – Input signal O – Output signal I/O – Bi-directional signal P – Power/Ground

6.0 Data Formats & Programmable Baud Rate Generator

The PL2303 controller supports versatile data formats and has a programmable baud rate generator. The supported data formats are shown on Table 6-1. The programmable baud rate generator supports baud rates up to 1.2M bps as shown in Table 6-2.

Table 6-1 Supported Data Formats

	Description
Stop bits	1 1.5 2
Parity type	None Odd Even Mark Space
Data bits	5, 6, 7, 8, or 16

Table 6-2 Baud Rate Setting

dwDTERate	Baud Rate
0012C000h	1228800
000E1000h	921600
00096000h	614400
00070800h	460800
00038400h	230400
0001C200h	115200
0000E100h	57600
00009600h	38400
00007080h	28800
00004B00h	19200
00003840h	14400
00002580h	9600
00001C20h	7200
000012C0h	4800
00000E10h	3600
00000960h	2400
00000708h	1800
000004B0h	1200
00000258h	600
0000012Ch	300
00000096h	150
0000004Bh	75

7.0 External EEPROM and Device Configuration

PL-2303 allows storing the configuration data in an external EEPROM. After reset, the first two bytes of EEPROM are checked. If the value is 067Bh, the EEPROM is valid and the contents of the EEPROM are loaded as the chip's default parameters. Otherwise, the chip's default setting is used. The content of EEPROM is shown in table below.

The Device Configuration Register is used to control some vendor-specific functions. The meaning of each bit in Device Configuration Register is shown in Table 7-2. Reserved and unused pins always set to the default value.

Table 7-1 EEPROM Contents

Bytes	Name	Description
1:0	EECHK	When the EEPROM is programmed, these two bytes is configured as 067B. After reset, they will be checked for the value. If matched, the following information will be loaded as the default parameters.
3:2	VID	USB Vendor ID
5:4	PID	Product ID
7:6	RN	Release number (BCD)
10:8	DCR	Device Configuration Register

Table 7-2 Device Configuration Register

Name	Bits	Definition	Default
23	RESERVED	Reserved	0
22	TRI_OUT	RS-232 Output Tri-state: 1: RS-232 output tri-state 0: RS-232 output in output mode	0
21	RW_MODE	Remote Wakeup Mode: 0: When engages remote wakeup, the device issues disconnect signal 1: When engages remote wakeup, the device issues resume signal	1
20	WURX	Enable Wake Up Trigger on RXD: 0 – Disabled; 1 – Enable Wake Up Trigger on RXD state changes.	0
19	WUDSR	Enable Wake Up Trigger on DSR: 0 – Disabled; 1 – Enable Wake Up Trigger on DSR state changes.	0
18	WURI	Enable Wake Up Trigger on RI: 0 – Disabled; 1 – Enable Wake Up Trigger on RI state changes.	1
17	WUDCD	Enable Wake Up Trigger on DCD: 0 – Disabled; 1 – Enable Wake Up Trigger on DCD state changes.	0

Name	Bits	Definition	Default
16	WUCTS	Enable Wake Up Trigger on CTS: 0 – Disabled; 1 – Enable Wake Up Trigger on CTS state changes.	0
15	RESERVED	Always set to one	1
14	RESERVED	Always set to zero	0
13	RESERVED	Always set to zero	0
12	RW_INH	Remote Wake Inhibit: 1 – Inhibit the USB Remote Wakeup function 0 – Enable the USB Remote Wakeup function	0
11:6	RESERVED	Always set to zero	0
5:4	RTSM	RTS Control Method: 00b – RTS is controlled by ControlBitMap. Signal is active low; 01 – RTS is controlled by ControlBitMap. Signal is active high; 10 – Drive RTS active when Downstream Data Buffer is NOT EMPTY; otherwise Drive RTS inactive. 11 – Drive RTS inactive when Downstream Data Buffer is NOT EMPTY; otherwise Drive RTS active.	0
3:1	RESERVED	Always set to zero	0
0	RSPDM	RS-232 Transceiver Shut-Down Mode: 1: Shut down the transceiver when USB SUSPEND is engaged 0: Do not shut down the transceiver even when USB SUSPEND is engaged	1

8.0 Electrical, Temperature & Timing Characteristics

8.1 Absolute Maximum Ratings

Table 8-1 Absolute Maximum Ratings

Items	Ratings
Power Supply Voltage	-0.3 to 6.0 V
Input Voltage	-0.3 to VDD+0.3 V
Output Voltage	-0.3 to VDD+0.3 V
Storage Temperature	-55 to 150 °C

8.2 DC Characteristics

Table 8-2 DC Characteristics

Parameter	Symbol	Min	Typ	Max	Units
Power Supply Current	I _{DD}	0.5	19	24	mA
Input Voltage					
Low	V _{IL}	--	--	0.3* V _{DD}	V
High	V _{IH}	0.7* V _{DD}	--	--	V
Output Voltage					
Low	V _{OL}	--	--	0.4	V
High	V _{OH}	3.5	--	--	V
Schmitt Trigger Threshold Voltage* ¹					
Negative going	V _{t-}	--	1.10	--	V
Positive going	V _{t+}	--	1.87	--	V
Output Voltage, 3.3V* ²					
Low	V _{OL}	--	--	0.4	V
High	V _{OH}	2.4	--	--	V
Input Leakage Current	I _L	-1	--	1	uA
Tri-state Leakage Current	I _{oz}	-10	--	10	uA
Input Capacitance	C _{IN}	--	3	--	Pf
Output Capacitance	C _{OUT}	--	3	--	Pf
Bi-directional Buffer Capacitance	C _{BiD}	--	3	--	Pf
Operating Voltage Range	--	4.4	5	5.25	V
Suspend Current	I _{SUS}	--	400	490	uA

*1. RS232 pins RXD_I, RI_I, DSR_I, DCD_I, CTS_I are 5V TTL Schmitt Trigger inputs.

*2. RS232 pins TXD, DTR_N, RTS_N are 3.3V tri-state outputs.

8.3 Clock Characteristics

Table 8-3 Clock Characteristics

Parameter	Min	Typ	Max	Units
Frequency of Operation	11.976	12.000	12.024	MHz
Clock Period	83.1	83.3	83.5	ns
Duty Cycle	45	50	55	%

8.4 Temperature Characteristics

Table 8-4 Temperature Characteristics

Parameter	Symbol	Min	Typ	Max	Unit
Operating Temperature	--	-40 ⁽¹⁾	--	85 ⁽¹⁾	°C
Junction Operation Temperature	T _J	-40	25	115	°C

Note: (1) – Test condition: Baud rate 115200 bps loop testing (4096 bytes/loop, random/fix 0xFF data transfer) over 30 minutes.

8.5 USB Transceiver Characteristics

Table 8-5 USB Transceiver Characteristics

Parameter	Symbol	Min	Typ	Max	Units
Rise and Fall Times: (10%—90%)	T _R	4	8	15	ns
(90%—10%)	T _F	4	8	15	ns
Cross Point	V _{CR}	1.3	--	2.0	V
Output Impedance	R _D	23	28	33	ohm
High Level Output	V _{OH}	2.8	--	--	V
Low Level Output	V _{OL}	--	--	0.7	V
High Level Input	V _{IH}	2.0	--	--	V
Low Level Input	V _{IL}	--	--	0.8	V

Note: C_L: 50pf

8.6 EEPROM Timing Diagram

8.6.1 Byte Write Timing

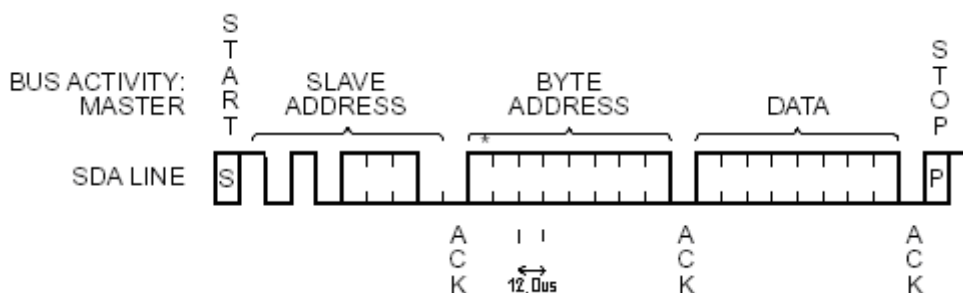

Figure 8-1 Byte Write Timing Diagram

8.6.2 Selective Read Timing

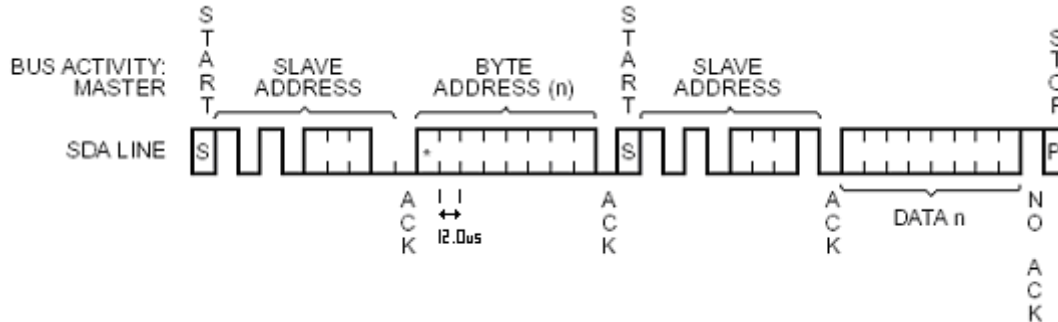

Figure 8-2 Selective Read Timing Diagram

8.7 Reset Timing Diagram

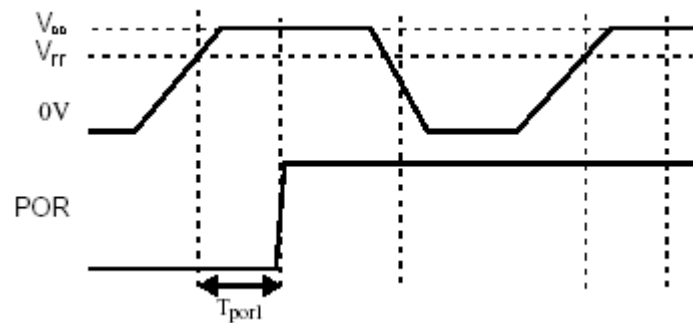

Figure 8-3 Reset Timing Diagram

Table 8-6 Power-On Reset

Symbol	Parameter and Condition	PORM5 (0.5μm 5V)			Units
		Min.	Typ.	Max.	
V _{rr}	V _{CC} rise relax voltage	3.0	3.4	3.7	V
T _{por1}	Power output low duration	4.4	6.3	8.2	μSec
	V _{CC} _{rise} @V _{rr} to POR _{rise} @ $\frac{1}{2}$ V _{CC} -V _{CC} slew rate=1V/1mSec				

9.0 Outline Diagram

9.1 SSOP28 Package

Table 9-1 Package Dimension

Symbol	Millimeter			Inch		
	Min	Nom	Max	Min	Nom	Max
b	0.22		0.38	0.009		0.015
E	7.40	7.80	8.20	0.291	0.307	0.323
E1	5.00	5.30	5.60	0.197	0.209	0.220
L	0.55	0.75	0.95	0.021	0.030	0.037
R1	0.09			0.004		
D	9.9	10.2	10.5	0.390	0.402	0.413
A			2.0			0.079
e		0.65			0.0256	
L1		1.25			0.050	
A1	0.05			0.020		
A2	1.65	1.75	1.85	0.065	0.069	0.073

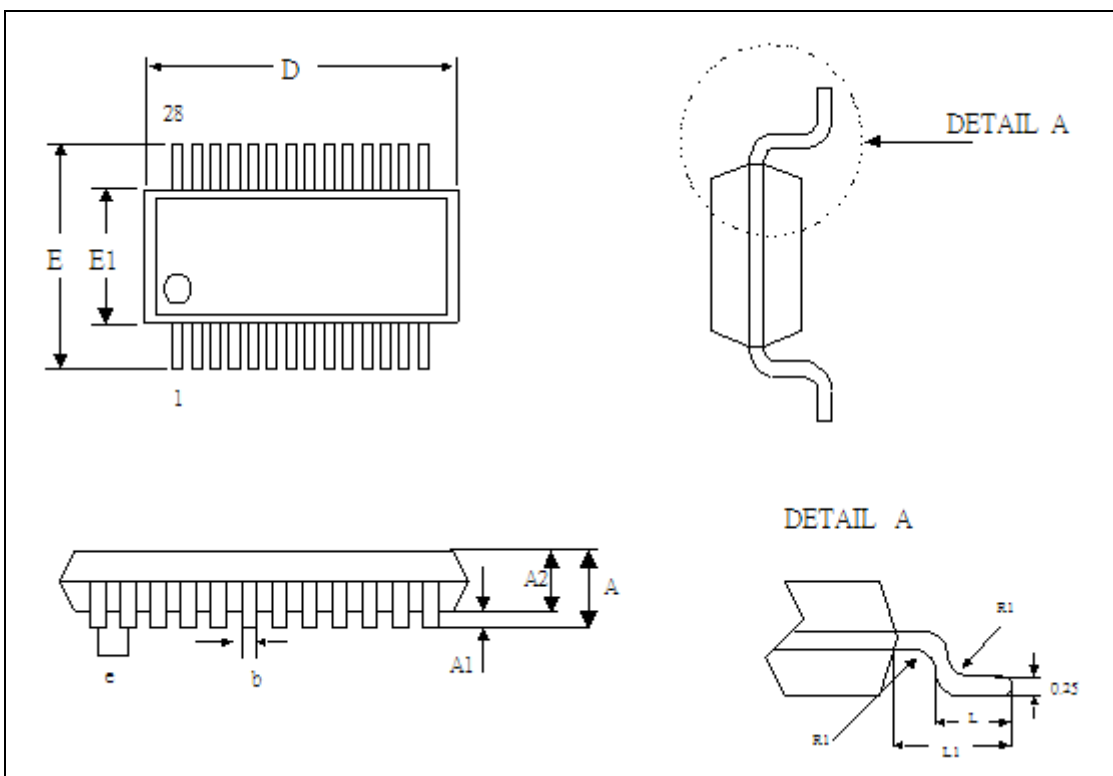

Figure 9-1 Outline Diagram of PL-2303 SSOP28

10.0 Reel Packing Information

10.1 Carrier Tape (SSOP-28)

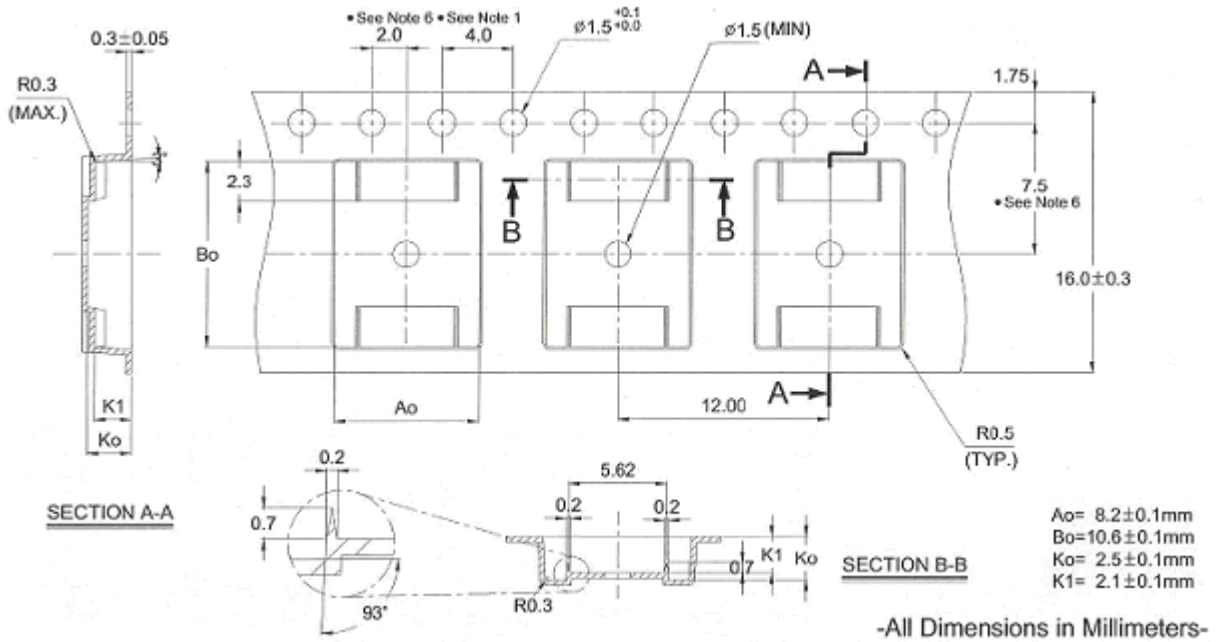

Figure 10-1a SSOP28 Carrier Tape

Notes:

1. 10 sprocket hole pitch cumulative tolerance ± 0.2
2. Camber not to exceed 1mm in 100mm.
3. Material: Black Polystyrene.
4. Ao and Bo measured on a plane 0.3mm above the bottom of the pocket.
5. Ko measured from a plane on the inside bottom of the pocket to the top surface of the carrier.
6. Pocket position relative to sprocket hole measured as true position of pocket, not pocket hole.
7. IC quantity per one reel: 1,000 (min) ~ 2,000 (max)

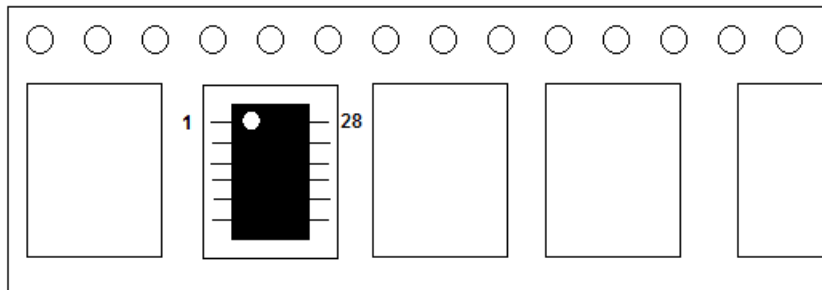

Figure 10-1b IC Reel Placements

10.2 Reel Dimension

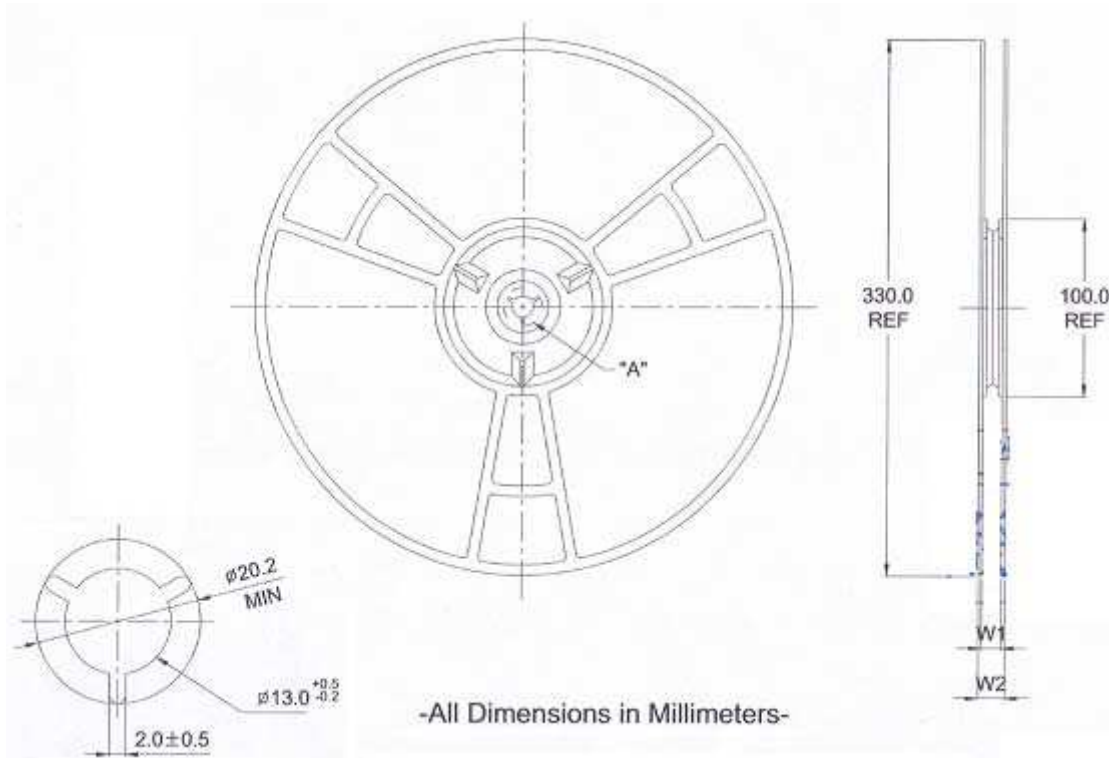

Figure 10-2 Reel Dimension

Table 10-2 Reel Part Number Information

Part Number	Normal Hub Width	W1 +0.3mm -0.2mm	W2 Max
RD33008SW-T + RD33008SW-T	16mm	16.8mm	22.2mm

11.0 Ordering Information

Table 11-1 Ordering Information

Part Number	Package Type
PL-2303	28-pin SSOP