



**HESTORE.HU**

elektronikai alkatrész áruház

**EN:** This Datasheet is presented by the manufacturer.

Please visit our website for pricing and availability at [www.hestore.hu](http://www.hestore.hu).



# ETH click™

## 1. Introduction

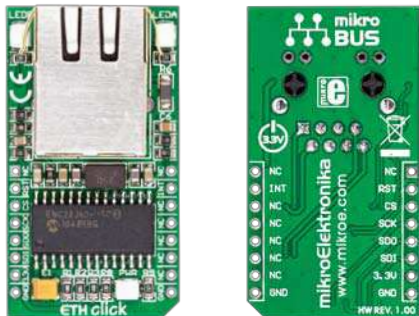

ETHClick is an accessory board in **mikroBus™** form factor. It features **ENC28J60**, a 28-pin, 10BASE-T stand alone Ethernet Controller with an on-board MAC & PHY, 8K Bytes of Buffer RAM and SPI serial interface. Chip supports programmable automatic retransmit on collision and automatic rejection of erroneous packets. Board contains standard RJ-45 connector, transmit, receive and power LEDs. On-board crystal oscillator ensures stable operation. Board is designed to use 3.3V power supply only.

## 2. Soldering the headers

Before using your click board, make sure to solder the provided 1x8 male headers to both sides of the board. Two 1x8 male headers are included with the board in the package.



2



Turn the board upside down, so that bottom side is facing you upwards. Place shorter parts of the header pins in the both soldering pad locations.

3

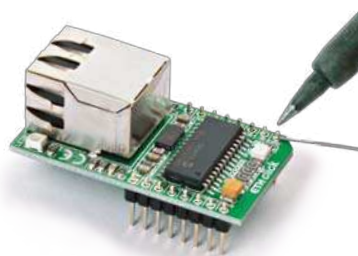

Turn the board upward again. Make sure to align the headers so that they are perpendicular to the board, then solder the pins carefully.

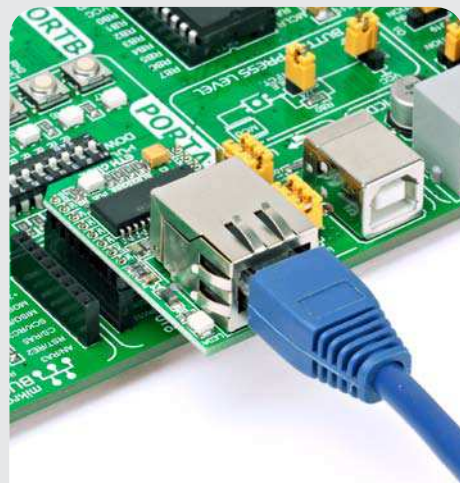

## 4. Board applications

Due to zero hardware configuration, this board is the perfect solution for adding Ethernet feature to your devices. ETH click is driven using SPI communication lines. Target applications include VoIP, Industrial Automation, Building Automation, Home Control, Security and Instrumentation, etc.

## 3. Plugging the board in

Once you have soldered the headers your board is ready to be placed into desired mikroBUS™ socket. Make sure to align the cut in the lower-right part of the board with the markings on the silkscreen at the mikroBUS™ socket. If all the pins are aligned correctly, push the board all the way into the socket.



click™  
BOARD  
[www.mikroe.com](http://www.mikroe.com)

ETH click Manual  
ver. 1.00



## 5. ETH click Board Schematics

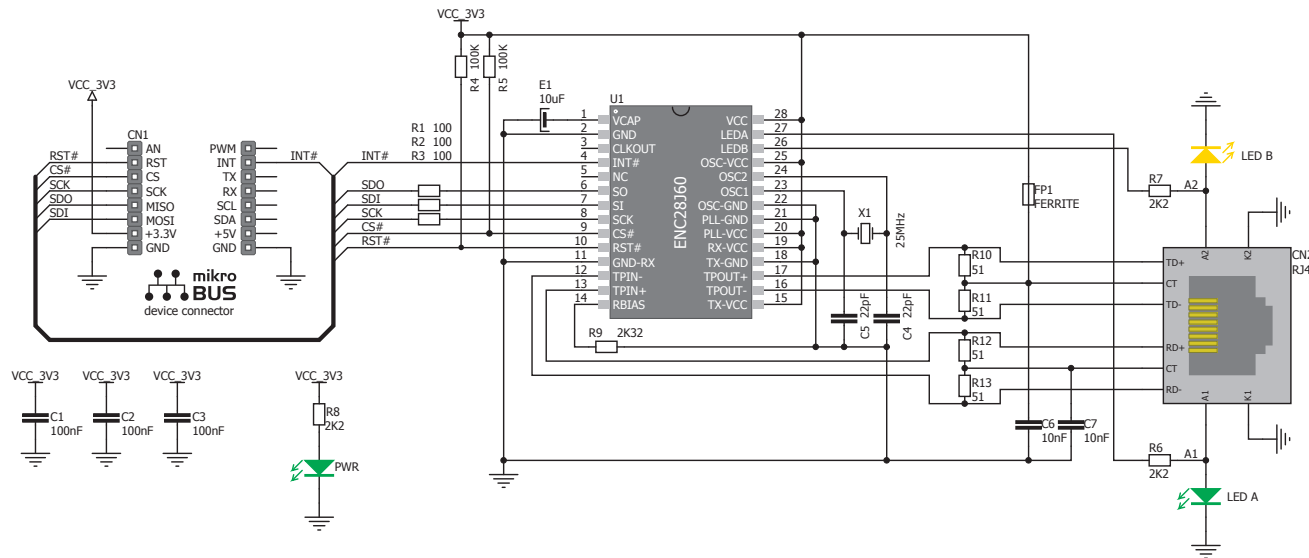

## 6. Power supply - 3.3V only



Board is designed to use 3.3V power supply only. If you need to add ethernet feature to your 5V prototype or development board, we recommend you to use other boards such as the Serial Ethernet Accessory Board:

<http://www.mikroe.com/eng/products/view/14/serial-ethernet-board/>

## 7. Code Examples

Once you have done all the necessary preparations, it's time to get your click board up and running. We have provided the examples for mikroC, mikroBasic and mikroPascal compilers on our **Libstock** website. Just download them and you are ready to start.



## 8. Support

MikroElektronika offers **Free Tech Support** ([www.mikroe.com/esupport](http://www.mikroe.com/esupport)) until the end of product lifetime, so if something goes wrong, we are ready and willing to help!

MikroElektronika assumes no responsibility or liability for any errors or inaccuracies that may appear in the present document.

Specification and information contained in the present schematic are subject to change at any time without notice. Copyright © 2012 MikroElektronika. All rights reserved.