



HESTORE.HU

elektronikai alkatrész áruház

EN: This Datasheet is presented by the manufacturer.

Please visit our website for pricing and availability at www.hestore.hu.

IQS550/525/512 Capacitive Controller Platform

IQS5xx-A000 – Trackpad/Touchscreen Controller

Multiple Channel Projected Capacitive Controller, with Proximity, Touch and Snap

The IQS5xx-A000 is a projected capacitive touch and proximity trackpad/touchscreen controller implementation on the IQS550, IQS525 and IQS512 platforms. The IQS5xx-A000 features best in class sensitivity, signal-to-noise ratio and automatic tuning of electrodes. Low power proximity detection allows extreme low power operation.

Main Features

- Proximity, touch and snap* on each channel
- Multi-touch and multi-hover support
- 3584 x 2304 resolution (IQS550)
- I²C™ communications interface
- ATI: automatic tuning for optimum sensitivity
- Supply Voltage 1.65V to 3.6V
- Proximity low power operation (<10uA)
- Event mode and streaming modes
- Dedicated proximity channel for long range proximity sensing
- Internal voltage regulator and reference capacitor
- On-chip noise detection and suppression

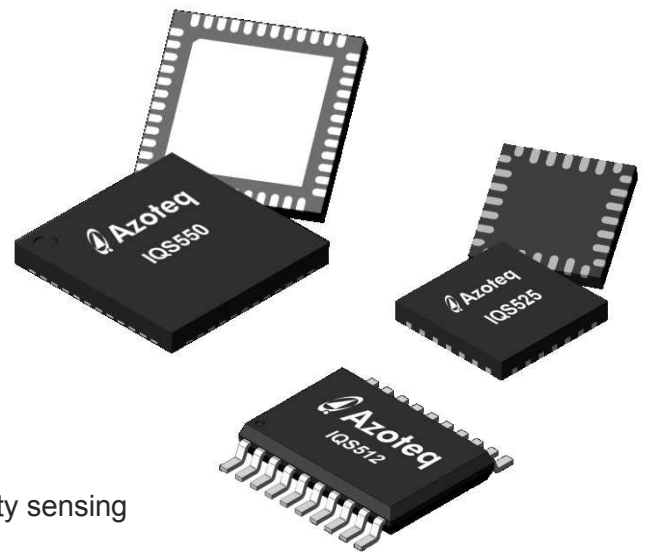

	IQS550	IQS525	IQS512
Maximum channels	150	25	12
Minimum report rate (with dual touch / max channels active)	100Hz	220Hz	400Hz
Resolution (for shown Tx Rx configurations)	3584 x 2304 (15 x 10)	1280 x 768 (6 x 4)	768 x 512 (4 x 3)

Applications

- Compact Capacitive Keyboards
- Remote Control Trackpads
- Appliances
- Navigation devices
- Kiosks and POS terminals
- E-readers
- Consumer electronics

Available options

T _A	QFN(7x7)-48	QFN(4x4)-28	TSSOP-20
-40°C to 85°C	IQS550	IQS525	IQS512

*patents pending



Contents

1	Overview	5
2	Packaging and Pin-out	6
2.1	<i>IQS550 - QFN48</i>	6
2.2	<i>IQS525 - QFN28</i>	8
2.3	<i>IQS512 - TSSOP20</i>	10
3	ProxSense[®] Module	12
3.1	<i>Individual Channels</i>	12
3.2	<i>Normal Mode Charging</i>	12
3.3	<i>ProxMode Charging</i>	12
3.4	<i>Automatic Mode Switching</i>	13
3.5	<i>Low Power Charging</i>	13
3.5.1	<i>Low-Power with Automatic Mode Switching</i>	13
3.5.2	<i>Low-Power in Normal Mode</i>	13
3.5.3	<i>Low-Power in ProxMode</i>	13
3.6	<i>Data Report Rate</i>	13
3.7	<i>Count Value Filter</i>	14
3.7.1	<i>Filter in Normal Mode</i>	14
3.7.2	<i>Filter in ProxMode</i>	14
3.8	<i>Environmental Drift</i>	14
3.8.1	<i>Long-Term Average Filter</i>	14
3.8.2	<i>Filter Halt</i>	14
3.9	<i>Auto Tuning (ATI)</i>	14
3.10	<i>Snap* (Metal-Dome click)</i>	14
3.11	<i>Proximity Sensitivity</i>	15
3.12	<i>Touch Sensitivity</i>	15
3.13	<i>Snap Sensitivity</i>	16
3.14	<i>Output Debounce</i>	16
3.15	<i>Touch and Proximity XY Data</i>	16
3.16	<i>Position Tracking</i>	17
3.17	<i>Touch Co-ordinate Filtering</i>	17
3.17.1	<i>Dynamic Filter</i>	17
3.17.2	<i>Static Filter</i>	17
3.18	<i>Hover / Prox Co-ordinate Filtering</i>	17
3.19	<i>Position adjustment / Calibration</i>	17
3.20	<i>Touch Strength</i>	17
3.21	<i>Physical Layout</i>	17



4	Additional Features	18
4.1	Event Mode Communication	18
4.2	RF Immunity	18
4.2.1	Design Guidelines	18
4.2.2	RF detection	18
4.3	Additional Non-Trackpad Channels	18
4.4	Active Channels / Disabling Channels	19
4.5	POUT / TOUT	19
4.6	Sleep	19
5	Communication	20
5.1	I ² C	20
5.1.1	Protocol	20
5.2	Control Byte	21
5.3	I ² C Read	21
5.4	I ² C Write	21
5.5	End of Communication Session / Window	21
5.6	Address-Command Description	21
5.6.1	Version Information Read (0x00)	21
5.6.2	XY Data Read (0x01)	21
5.6.3	Proximity Status Read (0x02)	23
5.6.4	Touch Status Read (0x03)	23
5.6.5	Count Data Read (0x04)	24
5.6.6	Long-Term Average Data Read (0x05)	25
5.6.7	ATI Compensation Read & Write (0x06)	25
5.6.8	Port Control (0x07)	25
5.6.9	Snap Status Read (0x08)	26
5.6.10	Control Settings (0x10)	26
5.6.11	Threshold Settings (0x11)	28
5.6.12	ATI Settings (0x12)	29
5.6.13	Filter Settings (0x13)	30
5.6.14	Timing Settings (0x14)	32
5.6.15	Channel Setup (0x15)	33
5.6.16	Hardware Config Settings (0x16)	35
5.6.17	Active Channels (0x17)	37
5.6.18	Debounce Settings (0x18)	37
5.6.19	ProxMode Proximity Status (0x20)	38
5.6.20	ProxMode Count Data Read (0x21)	38
5.6.21	ProxMode Long-Term Average Read (0x22)	38
5.6.22	ProxMode ATI Compensation Read/Write (0x23)	39
5.6.23	ProxMode ATI Settings (0x24)	39
6	Circuit Diagram	40
7	Electrical Characteristics	45
7.1	Absolute Maximum Ratings	45
7.2	Operating Conditions	46
7.2.1	General Operating Conditions	46



7.2.2	Power-up / Power-down Operating Conditions	46
7.2.3	Supply current characteristic	47
7.2.4	Report Rate	48
7.2.5	I/O port pin characteristics	48
7.2.6	Electrostatic discharge (ESD)	51
7.2.7	Thermal characteristics.....	52
8	Mechanical Dimensions	53
8.1	<i>IQS550 QFN(7x7)-48 Mechanical Dimensions</i>	<i>53</i>
8.2	<i>IQS550 Landing Pad Layout.....</i>	<i>54</i>
8.3	<i>IQS525 QFN(4x4)-28 Mechanical Dimensions</i>	<i>55</i>
8.4	<i>IQS525 Landing Pad Layout.....</i>	<i>56</i>
8.5	<i>IQS512 TSSOP20 Mechanical Dimensions</i>	<i>57</i>
8.6	<i>IQS512 Landing Pad Layout.....</i>	<i>58</i>
9	Device Marking	59
9.1	<i>IQS550 Marking.....</i>	<i>59</i>
9.2	<i>IQS525 Marking.....</i>	<i>60</i>
9.3	<i>IQS512 Marking.....</i>	<i>60</i>
10	Ordering Information	61
10.1	<i>IQS550 Ordering</i>	<i>61</i>
10.2	<i>IQS525 Ordering</i>	<i>61</i>
10.3	<i>IQS512 Ordering</i>	<i>61</i>
Changes:	62
	Release v1.00	62
	Release v1.01	62
	Release v1.02	62
	Release v1.03	63
	Release v1.04	63
	Release v1.05	63
	Release v1.06	63



1 Overview

The IQS550 / IQS525 / IQS512 is a capacitive sensing controller designed for multi-touch applications using projected capacitance touch panels. The device offers high sensitivity proximity/hover (PROX) detection and contact detection (TOUCH) through a selectable number of sensor lines (Rx's and Tx's).

Touch and proximity positions are calculated to provide multiple X-Y coordinates.

The device has an internal voltage regulator and Internal Capacitor Implementation (ICI) to reduce external components. Advanced on-chip signal processing capabilities yields a stable high performance capacitive controller with high sensitivity.

The controller uses the principle of projected capacitance charge transfer on the trackpad. When a conductive object such as a human finger approaches the sense plate it will decrease the detected capacitance. Observing the measured results at various sensing points on the trackpad enables the controller to determine PROX and TOUCH on all channels, and accurately determine the coordinates on the touch area. Multiple touch positions can thus be obtained.

Due to the advanced sensitivity of the device, MULTIPLE non-contact (proximity hover) co-ordinates can also be obtained. These hover co-ordinates can be used to predict the touch co-ordinate of an approaching user, before the touch is made, allowing innovative user interface options.

Multiple filters are implemented to suppress and detect noise and track slow varying environmental conditions, and avoid effects of possible drift. The Auto Tuning (ATI) allows for the adaptation to a wide range of touch screens without using external components.

An innovative addition, known as a *Snap** (*Click*), is also available on each channel. This adds another output additional to the PROX and TOUCH of each channel.

The trackpad application firmware on the IQS5xx is very flexible in design, and can incorporate standard touch sensors, trackpad / touchscreen areas (giving XY output data) and conventional snap-dome type buttons, all providing numerous outputs such as Prox, Touch, Snap, Touch Strength and actual finger position even before physical contact, all in one solution.



*This datasheet applies to the following **IQS550** version:*

Product Number 40 / Project Number 0 / Version Number 55



*This datasheet applies to the following **IQS525** version:*

Product Number 52 / Project Number 0 / Version Number 2



*This datasheet applies to the following **IQS512** version:*

Product Number 53 / Project Number 0 / Version Number 1



*patents pending



2 Packaging and Pin-out

2.1 IQS550 - QFN48

The IQS550 is available in a QFN(7x7)-48 package.

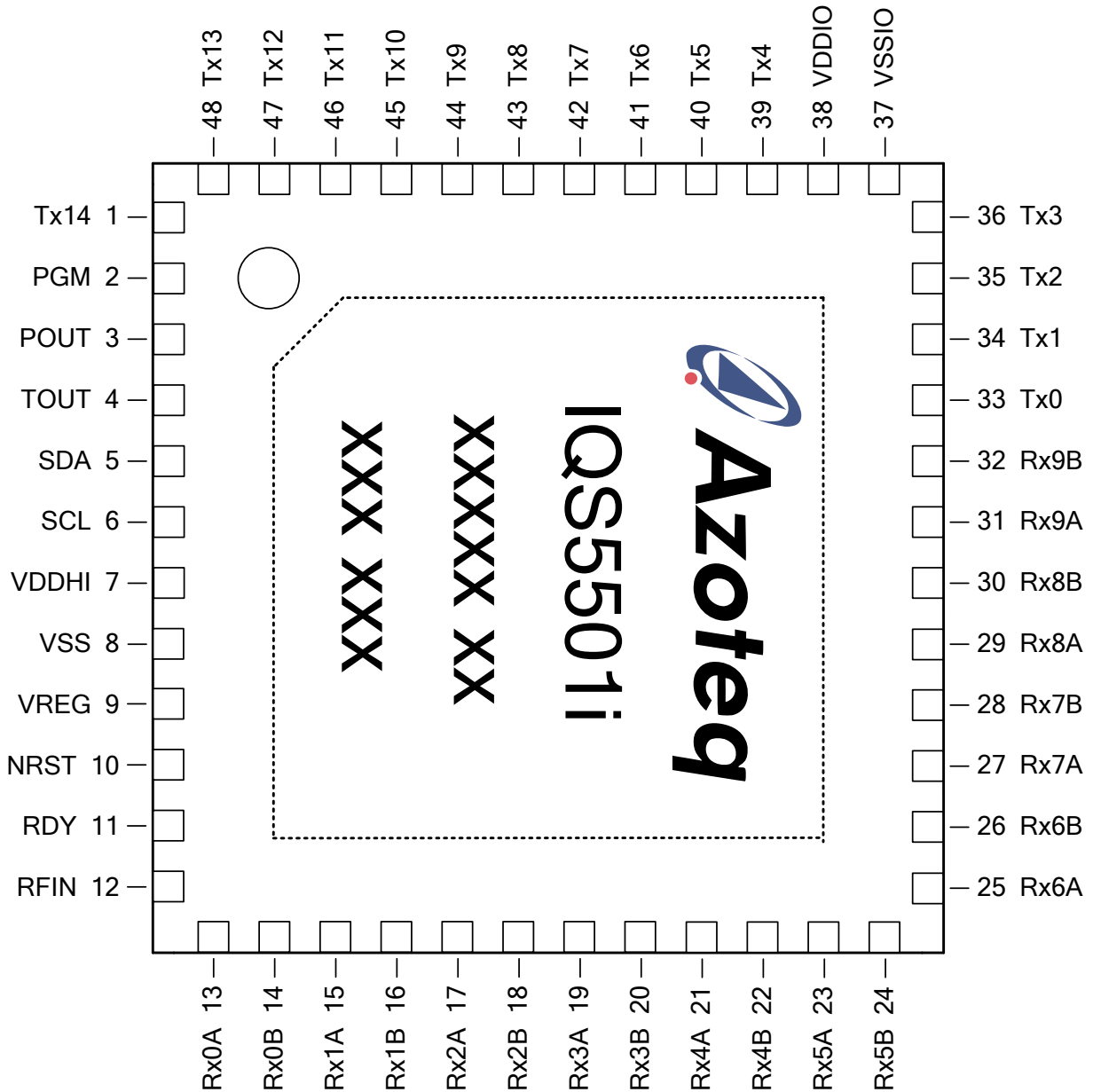

Figure 2.1 QFN Top View



Table 2.1 QFN48 Pin-out

Pin	Name	Description
1	Tx14	Transmitter electrode
2	PGM	Programming Pin
3	POUT	Global Prox Output
4	TOUT	Global Touch Output
5	SDA	I ² C Data
6	SCL	I ² C Clock
7	VDDHI	Supply Voltage
8	VSS	Ground Reference
9	VREG	Internal Regulator Voltage
10	NRST	Reset (active LOW)
11	RDY	I ² C RDY
12	RFIN	RF antenna input
13	Rx0A	Receiver electrode
14	Rx0B	Default ProxMode electrode
15	Rx1A	Receiver electrode
16	Rx1B	Note1
17	Rx2A	Receiver electrode
18	Rx2B	Note1
19	Rx3A	Receiver electrode
20	Rx3B	Note1
21	Rx4A	Receiver electrode
22	Rx4B	Note1
23	Rx5A	Receiver electrode
24	Rx5B	Note1

Pin	Name	Description
25	Rx6A	Receiver electrode
26	Rx6B	Note1
27	Rx7A	Receiver electrode
28	Rx7B	Note1
29	Rx8A	Receiver electrode
30	Rx8B	Note1
31	Rx9A	Receiver electrode
32	Rx9B	Note1
33	Tx0	Transmitter electrode
34	Tx1	Transmitter electrode
35	Tx2	Transmitter electrode
36	Tx3	Transmitter electrode
37	VSSIO	I/O Ground Reference
38	VDDIO	I/O Supply Voltage
39	Tx4	Transmitter electrode
40	Tx5	Transmitter electrode
41	Tx6	Transmitter electrode
42	Tx7	Transmitter electrode
43	Tx8	Transmitter electrode
44	Tx9	Transmitter electrode
45	Tx10	Transmitter electrode
46	Tx11	Transmitter electrode
47	Tx12	Transmitter electrode
48	Tx13	Transmitter electrode

Note1: Any of these can be configured through I²C as the ProxSense[®] electrode.



2.2 IQS525 - QFN28

The IQS525 is available in a QFN(4x4)-28 package. The production version is shown below.

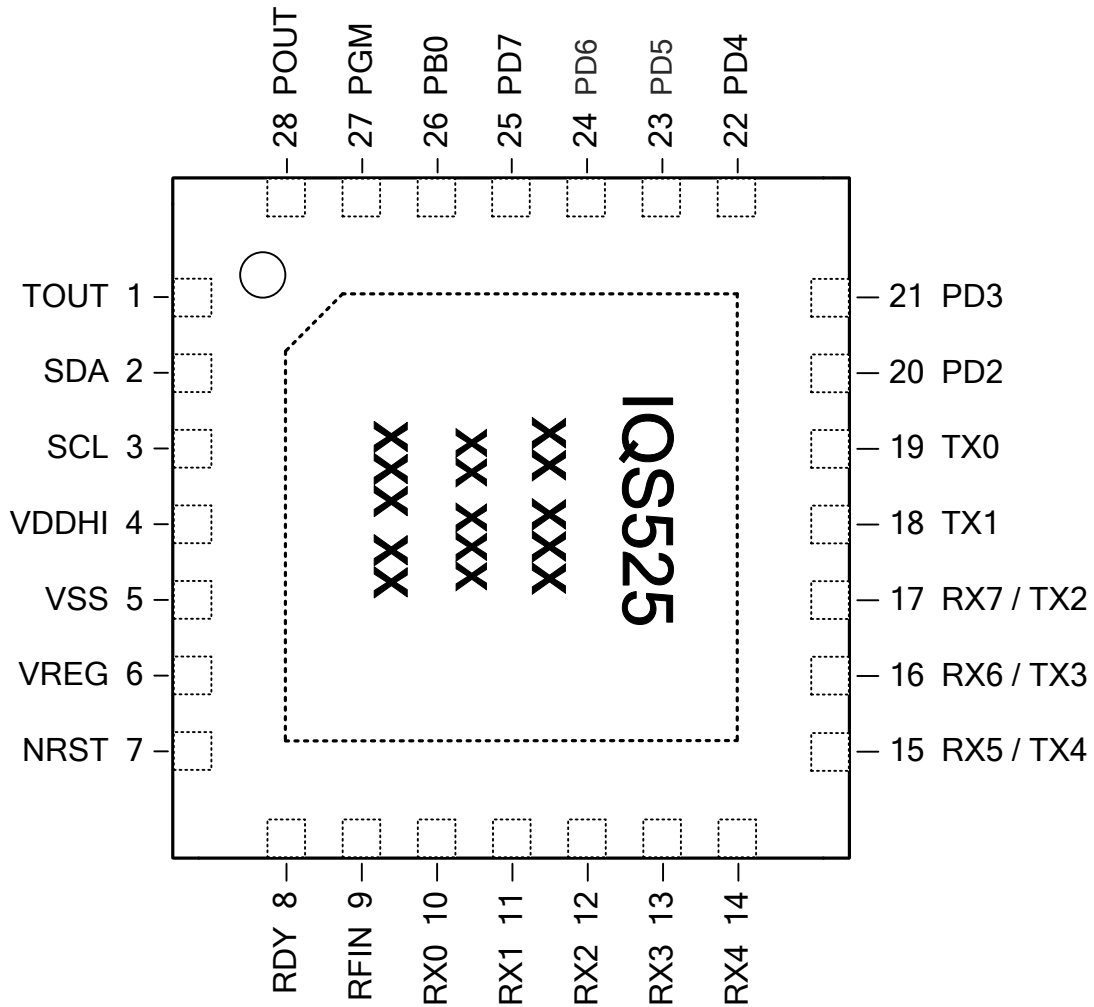

Figure 2.2 QFN Top View



Table 2.2 QFN48 Pin-out

Pin	Name	Description
1	TOUT	Global Touch Output
2	SDA	I ² C Data
3	SCL	I ² C Clock
4	VDDHI	Supply Voltage
5	VSS	Ground Reference
6	VREG	Internal Regulator Voltage
7	NRST	Reset (active LOW)
8	RDY	I ² C RDY
9	RFIN	RF antenna input
10	Rx0	Receiver electrode
11	Rx1	Receiver electrode
12	Rx2	Receiver electrode
13	Rx3	Receiver electrode
14	Rx4	Receiver electrode

15	Rx5 / TX4	Receiver / Transmitter electrode
16	Rx6 / TX3	Receiver / Transmitter electrode
17	Rx7 / TX2	Receiver / Transmitter electrode
18	Tx1	Transmitter electrode
19	Tx0	Transmitter electrode
20	PD2	General purpose I/O
21	PD3	General purpose I/O
22	PD4	General purpose I/O
23	PD5	General purpose I/O
24	PD6	General purpose I/O
25	PD7	General purpose I/O
26	PB0	General purpose I/O
27	PGM	Programming Pin
28	POUT	Global Prox Output



2.3 IQS512 - TSSOP20

The IQS512 is currently available in a TSSOP20 package. The production version is shown below.

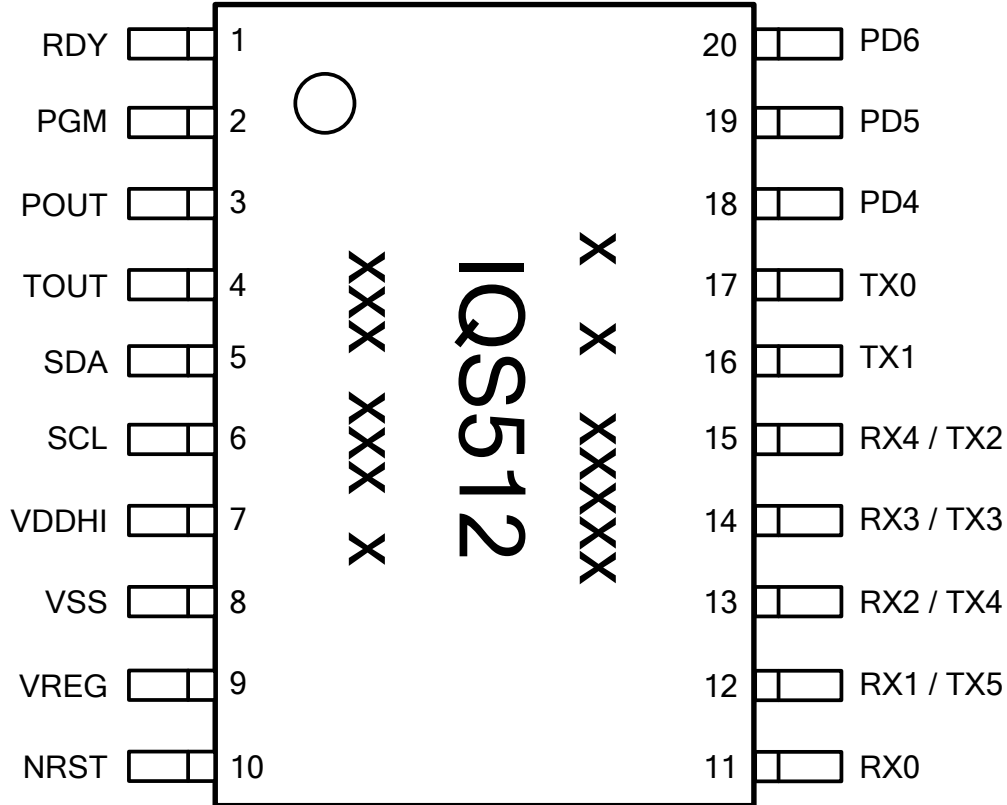

Figure 2.3 TSSOP Top View



Table 2.3 TSSOP20 Pin-out

Pin	Name	Description
1	RDY	I ² C RDY
2	PGM	Programming Pin
3	POUT	Global Prox Output
4	TOUT	Global Touch Output
5	SDA	I ² C Data
6	SCL	I ² C Clock
7	VDDHI	Supply Voltage
8	VSS	Ground Reference
9	VREG	Internal Regulator Voltage

10	NRST	Reset (active LOW)
11	Rx0	Receiver electrode
12	Rx1 / TX5	Receiver / Transmitter electrode
13	Rx2 / Tx4	Receiver / Transmitter electrode
14	Rx3 / Tx3	Receiver / Transmitter electrode
15	Rx4 / Tx2	Receiver / Transmitter electrode
16	Tx1	Transmitter electrode
17	Tx0	Transmitter electrode
18	PD4	General Purpose I/O
19	PD5	General Purpose I/O
20	PD6	General Purpose I/O



3 ProxSense[®] Module

The device contains a ProxSense[®] module that uses patented technology to provide detection of PROX and TOUCH, and calculate X and Y touch and/or proximity coordinates. A combination of hardware and software is used to obtain a set of measurements used for calculating the respective outputs.

An additional 'Snap' output is now available which adds further conventional button snap functionality above the trackpad area.

The system can operate in a Normal- or Prox-Mode charging configuration. In both of these a low-power charging scheme can also be implemented.

3.1 Individual Channels

On a trackpad type pattern (typically a diamond shape layout), each intersection of an Rx and Tx row/column forms a channel. Each channel has a count value, Long-Term Average, Proximity, Touch and Snap (if enabled) status. The default on the IQS550 device is 15x10 thus giving 150 channels in total.

Any channels not forming part of the trackpad area (see Section 4.3) can be used as separate sensors, and designed with any projected sensor pattern (Rx + Tx) as required by the design.

Each channel is limited in having a count value < 20000. If the ATI setting or hardware causes samples higher than this, the conversion will be stopped, and a value of '0' will be read for that relevant count value.

3.2 Normal Mode Charging

The sensors are scanned one Tx transmitter at a time, until all have completed, with all enabled Rx's charging in each Tx 'time-slot'. This then provides all the sample data for the touch panel, which can be used to obtain Long-term Average values, Prox and Touch status, and finally full XY co-ordinate information.

In a 15x10 system (15 Tx and 10 Rx), 15 conversion timeslots occur, with each timeslot

consisting of the acquisition of 10 receiver channels.

Communication is only done once all these timeslots are completed.

3.3 ProxMode Charging

An additional ProxMode charging scheme is selectable, and aimed at providing long range proximity detection, useful for implementing low-power modes during periods of no user activity. The ProxMode channel is configurable, and can function in either self- or projected- capacitive mode. Standard sensor electrode design for self or projected channels must be adhered for optimal proximity sensing.

The system performs a ProxMode channel acquisition (while waiting in a low-power state for the conversion to complete). Once complete, the data is processed, updating the proximity status. A low duty cycle can then also be selected, further reducing the total current consumption. With the superior sensitivity of the ProxSense[®] hardware, the system will be fully operational in Normal Mode charging before the user is within operating distance of the sensors.

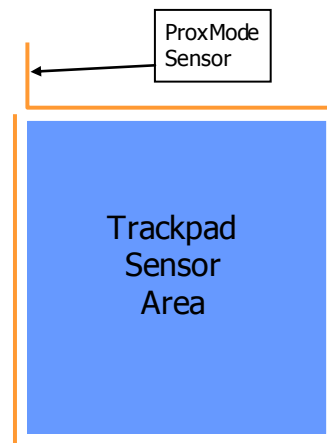

Figure 3.1 ProxMode Layout Suggestion

If a trackpad is implemented on which a ProxMode is to be designed, it is recommended to route the ProxMode Rx channel around the perimeter of the trackpad sensors. The channel is then configured in projected capacitive sensing mode, and all the Tx's on the trackpad sensors are enabled.



This gives a good proximity sensor in the trackpad area. Adding a ground track between this Rx and the trackpad channels also improves the proximity sensing.

3.4 Automatic Mode Switching

With this enabled, automatic interaction and switching between Normal- and ProxMode charging is achieved. For the automatic mode (and also low-power charging) a selectable *ModeTime* is used.

After being correctly configured, the system will operate in ProxMode, until a proximity event is sensed on the ProxMode channel. At this point the system will switch to Normal Mode charging, ready to sense user interaction with the trackpad channels.

The system will revert back to ProxMode charging if no prox, touch or snap condition is found on the Normal Mode channels for a period of *ModeTime*.

When in ProxMode, a Normal Mode conversion will automatically take place roughly every 4s, but no communication for this cycle will be presented. This cycle is simply to keep the Long-Term Average values of the Normal Mode channels up to date.

3.5 Low Power Charging

By enabling low-power, the device will add a *sleep* between conversions. If no prox, touch or snap is sensed for *ModeTime*, then the system will go into the low duty-cycle charging mode. As soon as a channel output is sensed, the system will resume full-speed charging. Introducing this low-power duty cycle into the system naturally decreases total power consumption of the device, dependant on the selected *LPTime*.

3.5.1 Low-Power with Automatic Mode Switching

If it is possible to have a ProxMode sensor, the best is to use the system in automatic mode switching, combined with low-power charging. This will give by far the lowest power consumption, and works as follows:

The system charges in ProxMode until a PROX event occurs, and since automatic

mode is enabled, it will switch to Normal Mode charging which occurs at full-speed (no low-power). If no activity occurs for *ModeTime*, then the system will revert to ProxMode charging. Here it will continue at full-speed for a further *ModeTime*, and after this, low-power charging will take place on the ProxMode channel.

This gives the lowest power consumption, combined with a possibility of good range proximity (sensor and system dependent) which helps with the wake-up response time of the system.

3.5.2 Low-Power in Normal Mode

If automatic mode is NOT selected, the system will work as follows in Normal Mode (possibly the hardware does not allow for a ProxMode electrode):

After *ModeTime* of no prox, touch or snap, the system will stay in Normal Mode, but all channels will with a low-power duty cycle. If an event is sensed on a Normal Mode channel, full-speed charging will commence immediately to provide fast response. This will not provide the same low power consumption as found in ProxMode, since more channels are usually processed in Normal Mode, thus increasing the consumption (longer/more processing means higher ratio of high current operation time versus sleep time).

3.5.3 Low-Power in ProxMode

If automatic mode is NOT selected, and the system is in ProxMode charging:

After a period of *ModeTime* of no PROX on the ProxMode sensor, the ProxMode channel will charge in the low-power mode. If a PROX is sensed on this channel, it will stay in ProxMode, and will charge at full-speed.

3.6 Data Report Rate

The report rate of the device depends on the charge transfer frequency, number of enabled channels, and the count value of the channels. The length of communications initiated by the master device will also affect the report rate. There is a maximum rate governed by the



time taken to process the data, but the rate can be decreased if the other factors extend the cycle.

The frequency of the transfers can be adjusted. An optimal transfer frequency must be selected for a specific touch panel application by choosing the optimal setting.

High count values will give good resolution and proximity hover performance, but could decrease the report rate.

For an indication of the expected report rate, please refer to Table 7.7.

3.7 Count Value Filter

3.7.1 Filter in Normal Mode

To improve hover reliability, a count value filter is implemented in normal mode. Since this would greatly reduce the response rate for normal touch operation, it is only active when no touch or snap output is sensed. When these occur the filter is bypassed and fast response is achieved. This filter can also be disabled and adjusted.

3.7.2 Filter in ProxMode

For the ProxMode channel, a count value filter is implemented. This allows the user to increase the sensitivity of the ProxMode electrode drastically to obtain good proximity distance, whilst the filter retains the stability of the count values and thus the PROX output. The filter damping factor can be adjusted, and the filter can also be totally disabled.

3.8 Environmental Drift

The Long-Term Average (LTA) can be seen as the baseline or reference value.

3.8.1 Long-Term Average Filter

The Long-Term Average filter is calculated from the sample count value of each channel. This allows the device to adapt to environmental (slow moving) drift. To force an update, a reseed command can be executed.

3.8.2 Filter Halt

To ensure that the Long-Term Average filters

do not adapt during a prox, touch or snap event, a filter halt scheme is implemented on the device. The designer can choose between filter halt times ranging from 0.5 to 127 seconds, in multiples of 500ms. Also 'Always Halt' can be selected (value = 255). Once this filter halt time has elapsed, a recalibration (reseed) is executed, resetting all outputs and incorporating the current environment into the new baseline.

3.9 Auto Tuning (ATI)

The ATI is a sophisticated technology implemented in the new ProxSense® devices to allow optimal performance of the devices for a wide range of sensing electrode capacitances, without modification to external components. The ATI allows the tuning of two parameters, ATI Multiplier and ATI Compensation, to adjust the sample value for an attached sensing electrode.

ATI allows the designer to optimise a specific design by adjusting the sensitivity and stability through the adjustment of the ATI parameters.

With a selected ATI C value, the ATI Compensation can then be automatically configured for an adjustable channel target sample value by means of an automated ATI function.

The device requires that for optimal performance on the trackpad, all these channels must be configured to have similar sample values.

Different sets of settings exist for trackpad, non-trackpad and the ProxMode channel.

3.10 Snap* (Metal-Dome click)

When adding a metal snap-dome button as the overlay to the trackpad pattern, an additional 'Snap' function is available. The device is able to distinguish between a normal 'touch' on the overlay and an actual button 'snap', which depresses the metal dome onto the Rx/Tx pattern. This output is referred to as a snap. The design must be configured so that a snap on the metal dome will result in a channels' sample value falling well below the

*patent pending



Long-Term Average value for that channel.

A few suggestions are:

- Place the snap-dome directly above a channel (thus exactly on the Rx-Tx junction)
- Alternatively place the snap-dome in the centre of the diamond pattern, and add a round pad of the second sensor inside the diamond.
- The snap-dome must consist of the standard metal dome or carbon circle pattern (or similar conductive material) on the inside of the dome.
- This conductive dome must be of adequate size to provide good count value deviation below the Long-Term Average of the channel on a snap.
- The conductive dome must however not be too big relative to the pitch of the Rx/Tx sensors, so as to not block the field lines for the trackpad sensing.
- No electrical connection between the snap-dome and the Rx-Tx must be made. Usually PCB solder-mask is adequate. Optimally the sensors are covered by solder-mask, with the snap-dome directly above.
- The snap-dome overlay must not have varying air-gaps between itself and the sensors. Thus having the overlay securely fastened to the PCB is ideal. A variable air-gap causes sporadic sensing, and gives unreliable data.

If required, the function can be enabled, and the snap bits are then available to the user, similar to the prox and touch status bits. The Long-Term Average filter halt is also implemented on snap outputs.

With the high level of sensitivity found on the device, a touch- / track-pad can now be projected through conventional keys, providing full XY functionality behind these without requiring additional real-estate or sense ICs.

For more information, refer to the Application Note: AZD068 – Trackpad Design Guide.

3.11 Proximity Sensitivity

The proximity threshold of the channels is calculated as a delta value of the count value relative to the Long-Term Average value. A PROX status is detected when the count value changes by more than the selected delta. Any 8 bit value can be used as the proximity threshold delta value.

A different threshold is available for the trackpad, non-trackpad and the ProxMode channels.

Note: For the trackpad channels (projected capacitive) the samples will increase with user interaction, thus the threshold is this value ABOVE the Long-Term Average.

However for the ProxMode channel, if self capacitive mode is selected, the samples will decrease during user interaction, thus the threshold is this value BELOW the Long-Term Average.

If ProxMode Reverse sensing (ControlSettings1 byte) is enabled, the proximity output will trigger on a positive or negative change. It has been found that for certain battery applications, even though projected capacitance is selected, a self-capacitive effect can occur.

3.12 Touch Sensitivity

The touch sensitivity of the channels is a user defined threshold calculated as a ratio of count value to the Long-Term Average for each channel. Note that a user touching the sensor will cause the count value to increase. A smaller fraction will thus be a more sensitive threshold (for example 1/64 is more sensitive than 1/16)

The touch threshold for a specific channel is calculated as follows:

$$\text{Threshold} = \text{LTA} \times (1 + \text{Multiplier} / 2^{\text{SHIFTER}})$$

where the MULTIPLIER and SHIFTER values can be adjusted.

If the count value increases with more than this threshold value, then a touch condition is true.

A touch is NOT calculated for the ProxMode channel, but two sets of thresholds are available for the trackpad and non-trackpad channels.



3.13 Snap Sensitivity

The Snap threshold is a delta value BELOW the Long-Term Average of the channel. When a snap is performed, a self capacitive effect is observed, and the sample value will decrease. To be able to distinguish between a snap, and a normal touch release, the hardware must be designed so that a snap forces the samples below the Long-Term Average value. A 16-bit value can be selected for this delta.

When a user touches the key, the samples on that specific channel will increase and a normal touch and prox output will trigger. When the user pushes the button down (snap), the samples will decrease (removing the prox and touch outputs) below the Long-Term Average value, and a snap output can be observed.

One global Snap threshold is implemented.

3.14 Output Debounce

All the channel outputs (proximity, touch and snap) are debounced according to the selectable debounce values. The default debounce values are shown in the table, note that a debounce value = 1 means that two samples satisfying the condition must be met before the output is activated. A debounce value of 0 thus means no debouncing takes place. The default touch debounce setting is set to no debouncing. This is due to the fact that with a 15x10 sensor, debouncing adds too much delay, and fast movements on the touch panel cannot be debounced fast enough to provide reliable XY output data. With the advanced sensitivity of the sensors, a touch is regarded as a large deviation this does not pose any problems.

Table 3.1 Debounce values

	Set	Clear
Proximity	4	4
Touch	0	0
Snap	1	1

3.15 Touch and Proximity XY Data

Five XY co-ordinates are available to the master (*Note:* The IQS512 is limited to 2). These are the 5 ‘hardest/biggest’ touches/proximity points sensed on the sensor panel. The XY data is sent out in order, from hardest to least hard touch/prox. The IC however tracks each specific XY position from cycle to cycle (since they will move in position relative to their touch strength) and attaches the relating ID tag with each co-ordinate.

5 unique ID tags are available for TOUCH co-ordinates, namely values of 1-5, and 5 ID’s for HOVER co-ordinates, namely 129 - 133.

256 steps are implemented between the relative Rx’s and also between the relative Tx’s, giving x coordinates that range from 0 to $(256 \times (\text{TrackpadRxs}-1))$.

The Y coordinates will have an output range from 0 to $(256 \times (\text{TrackpadTxs}-1))$. Thus in a 15x10 system: $(0 < y < 3584)$ and $(0 < x < 2304)$.

It is not necessary to read the proximity, touch or snap status data to obtain a global picture of the touch panel status. The XY data stream contains all information required during normal operation.

The XY data stream is lead by an information byte showing certain status bits, as well as how many active co-ordinates are currently available (the number of touches + hovers).

For each co-ordinate, the ID tag is sent first, followed by an X co-ordinate, a Y co-ordinate, and finally the touch strength. All of these are 2 bytes each.

A total of 5 (2 on IQS512) co-ordinates are always available to be read, but if the information byte indicates fewer co-ordinates are active, the master is allowed to stop reading after the relative co-ordinate. A global snap indication bit is also available in the information byte and will indicate when the individual status bits must be read.

On the IQS525 and IQS512, an option exists to force the sensing to calculate a single XY output, based on all the sensing data on the trackpad channels. This can be useful for certain applications with non-ideal overlays.



Incorrect multiple points could be detected due to the overlay, where a single output using all trackpad data would still give a reliable position.

3.16 Position Tracking

Position filtering is performed on-chip, and is configurable through the I²C interface. For filtering to be possible, position tracking is required.

Each calculated XY co-ordinate must be matched with the previous co-ordinates to be able to identify a specific point. The co-ordinates are identified by an identification value (ID) that is provided along with each XY data packet. This ID allows the master to differentiate between Touch and Hover co-ordinates, and also track specific points.

3.17 Touch Co-ordinate Filtering

Selecting between dynamic, static or no filtering is possible.

3.17.1 Dynamic Filter

Relative to the speed of movement of a co-ordinate, a dynamic filter is implemented on the touch co-ordinates.

The filter dynamically adjusts the amount of filtering (damping factor) relative to the movement of the XY co-ordinate. When fast response is required, less filtering is done. Similarly when a co-ordinate is stationary or moving at a slower speed, then more filtered XY co-ordinates are obtained.

3.17.2 Static Filter

Co-ordinates filtered with a fixed but configurable damping factor are obtained when using the static filter. It is recommended that the dynamic filter be used due to the advantages of a dynamically changing damping value.

3.18 Hover / Prox Co-ordinate Filtering

A static filter is implemented on the hover co-ordinates, and can be adjusted independently from the touch co-ordinate filter. The hover points are usually filtered much more than the

touch points, since the hover operates closer to the system's noise floor.

3.19 Position adjustment / Calibration

No position calibration is required. The position data starts at the centre of the first Rx/Tx electrode, and ends at the centre of the last Rx/Tx electrode.

3.20 Touch Strength

This value indicates the strength of the touch/proximity with the touch screen. The touch strength information can be used to add extra effects in applications. Two possible applications would be broadening the paintbrush width while drawing on the touch screen, or sensing presses of the finger while moving across a touch panel, without lifting your finger. The calculated value of the touch strength can be seen as providing 'Z' direction data.

This strength value varies according to the sensitivity of the sensors.

3.21 Physical Layout

The Rx and Tx channels must be connected sequentially for the trackpad channels, as shown in Figure 3.2. To assist routing, they can be chosen to be ascending or descending, this will just invert the X or Y output data.

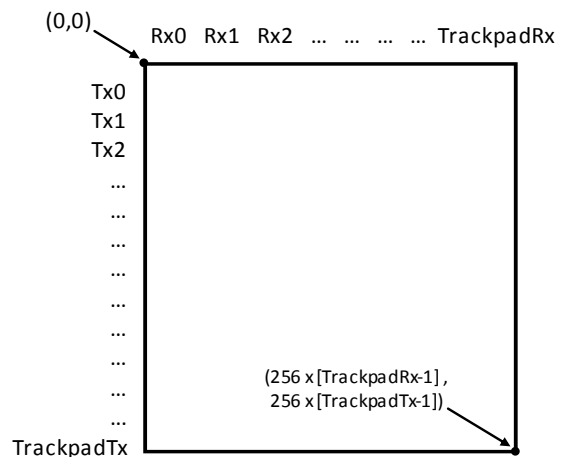

Figure 3.2 Hardware Rx/Tx Setup



4 Additional Features

4.1 Event Mode Communication

The device can be set up to bypass the communication window when no activity is sensed. This could be enabled if a master does not want to be unnecessarily interrupted during every charging cycle. The communication will resume (RDY will indicate available data) if a proximity, touch or snap is sensed. It is recommended that the RDY be placed on an interrupt-on-pin-change input on the master.

As soon as the active output is no longer sensed, one communication cycle will still be available to be able to read that this event has ended, and then the communication will again cease until further interaction with the sensors are observed.

Using the Event Mode will typically work as follows:

The master sends a command to enable event mode. The device then continually does conversions without interaction (communication) with the master, until a proximity, touch or snap event occurs, which is most likely the first time that the master will be interested in the data. The master reads data during the communication windows, until the event is over, and then the communication windows will again be bypassed.

If however the master would like to force communication session, it must perform a single byte read from the device at any time (obviously without the need for RDY to go HIGH, which it won't since communication is skipped). The master will read one byte with a value of 0xA3, and then the master gives an I²C STOP. This shows that a request for a communication session is successful. Now when the next set of data is ready, a temporary communication session will be forced (and RDY will be set as usual to indicate this). This will however not disable Event Mode, and if this is required, it must be disabled during this single temporary window.

The different events to trigger the Event Mode, namely ProxMode Proximity, Proximity, Touch

or Snap, can be configured. For example all events except Touch can be disabled, and then communication will only be available when a touch output is detected.

4.2 RF Immunity

The IQS5xx has immunity to high power RF noise. In this section general design guidelines will be given to improve noise immunity and the noise detection function is explained.

4.2.1 Design Guidelines

To improve the RF immunity extra decoupling capacitors are suggested on V_{REG} and V_{DDHI} .

Place a 100pF in parallel with the 1uF ceramic on V_{REG} . Place a 1uF ceramic on V_{DDHI} . All decoupling capacitors should be placed as close as possible to the V_{DDHI} and V_{REG} pads.

PCB ground planes also improve noise immunity.

4.2.2 RF detection

In cases of extreme RF interference, on-chip RF detection is provided. By connecting a suitable RF antenna to the RF input pin, it improves detection of RF noise. The RF noise is identified on-chip, and suitable steps are taken to block the corrupt samples from influencing the output data. In standard designs this will not be necessary, since the on-chip sensing has a good immunity to noise interference.

4.3 Additional Non-Trackpad Channels

If there is a requirement for standard projected sensors that do not form part of the trackpad area, then this can be configured. The trackpad sensors can be reduced by defining the *TrackpadRx* and *TrackpadTx* parameters. These define where the trackpad ends. Any Rx/Tx channels remaining can be used as standard capacitive sensing buttons/sensors, and only proximity, touch and snap data is processed on these channels, no XY data. An example is shown in Figure 4.1. Here the trackpad area will be 8x7, and an additional 14 sensors are available outside of this area. Clearly the following must be true:



$$\text{TrackpadRx} \leq \text{TotalRx}$$
$$\text{TrackpadTx} \leq \text{TotalTx}$$

Not all of the channels inside the blocks need to be used, these can also individually be disabled, see Section 4.4.

Separate proximity and touch thresholds, as well as separate ATI settings are implemented on these non-trackpad channels.

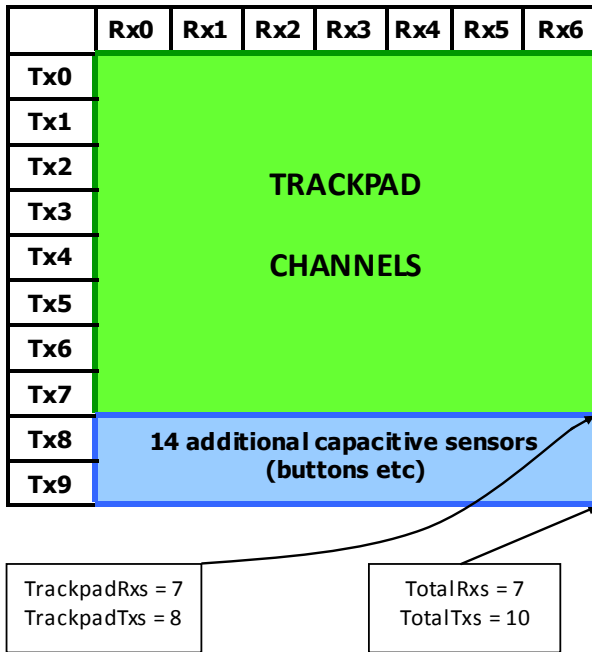

Figure 4.1 Defining trackpad area

4.4 Active Channels / Disabling Channels

If irregular shape trackpads are required, or certain channels are not required, they can individually be disabled. These channels are then skipped, and no calculation is performed on these channels.

This is useful for example when a round trackpad is used. Here the trackpad area is defined by *TrackpadTx* and *TrackpadRx*, which is a square selection of channels, but some corner channels do not exist due to the

round structure. To allow accurate XY coordinates to be calculated, the non-existing corner channels can be disabled. It is recommended that all non-existent (not part of physical sensor layout) channels falling within the selected *TotalRx* and *TotalTx* block should be disabled.

Note that non-linear edge effects can still take place on such an irregular shaped trackpad, and if the design allows, it is better to keep a square sensor, and process the XY values to only output the required shapes' co-ordinates.

4.5 POUT / TOUT

The POUT I/O is HIGH if there is proximity on any of the channels (including ProxMode channel). This can for example be used to control backlighting in the design.

The TOUT output indicates a touch or snap condition on any of the Normal Mode channels.

4.6 Sleep

A constant low-power sleep state can be added to each complete system cycle. This will clearly reduce the average operating current of the device, at the expense of reduction in response rate.

When activated, this is permanently added in **only the Normal Mode** charging, irrespective of the low-power setting/state.

In current critical applications, where a response rate slower that the full-speed rate is acceptable, this further reduction in power consumption can be implemented.

The length of the time that the system is in this sleep state each cycle is set by changing the *SleepTime* value. This value will in most cases be $\leq 20\text{ms}$ to still obtain good performance.



5 Communication

5.1 I²C

The device can communicate in I²C using the standard communication protocol. An additional RDY signal is added which indicates when the communication window is available, it is thus optimal for response rate to use the RDY as a communication trigger, but polling is also available as a less attractive option. Designing the RDY to connect to an interrupt-on-change input is recommended for easier implementation and optimal response time.

The first communication window is available before the device performs any sensing or calculations, to allow initial configuration to take place.

Standard I²C clock stretching can occur, so monitoring the availability of the SCL is required, as per usual I²C protocol.

5.1.1 Protocol

The I²C currently employs an ‘address-command’ type structure instead of a memory map. What this means is that data bytes cannot be individually addressed, but can be obtained by configuring a relevant address-command on the device to specify which blocks of data to read or write. Specific data is thus grouped together, and identified / accessed by means of the ‘address-command’ relating to the specific group.

Table 5.1 I²C Address-Command Structure

Command Value	Command Description	Read/Write
0x00	Version Info	R
0x01*	XY Data (default)	R*
0x02	Proximity Status	R
0x03	Touch Status	R

0x04	Count Values	R
0x05	Long-Term Averages	R
0x06	ATI Compensation	R/W
0x07	Port Control	R/W
0x08	Snap Status	R
0x10	Control Settings	R/W
0x11	Threshold Settings	R/W
0x12	ATI Settings	R/W
0x13	Filter Settings	R/W
0x14	Timing Settings	R/W
0x15	Channel Setup	R/W
0x16	Hardware Config Settings	R/W
0x17	Active Channels	R/W
0x18	Debounce Settings	R/W
0x20	PM Proximity Status	R
0x21	PM Count Values	R
0x22	PM Long-Term Averages	R
0x23	PM ATI Compensation	R/W
0x24	PM ATI Settings	R/W

For example, to read out the proximity status bytes, the following must be done:

```

START -->
CONTROL BYTE(Write) -->
0x02 (proximity read address-command) -->
REPEATED-START -->
CONTROL BYTE(Read) -->
ProxByte[0] ->
...
ProxByte[TotalTx-1] -->
STOP
    
```



5.2 Control Byte

The 7-bit device address is '1110100'. Currently the sub-address is fixed at '00'. An option does exist to change the device address if needed.

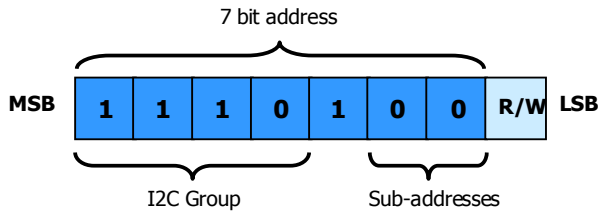

Figure 5.1 I²C Control Byte

5.3 I²C Read

To read from the device a *current address read* can be performed. This assumes that the address-command is already setup as desired.

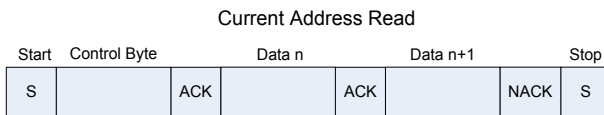

Figure 5.2 Current Address Read

If the address-command must first be specified, then a *random read* must be performed. In this case a WRITE is initially performed to setup the address-command, and then a repeated start is used to initiate the READ section.



Figure 5.3 Random Read

5.4 I²C Write

To write settings to the device a *Data Write* is performed. Here the Address-Command is always required, followed by the relevant data bytes to write to the device.

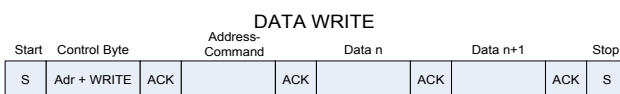

Figure 5.4 Data Write

5.5 End of Communication Session / Window

Similar to other Azoteq I²C devices, to end the communication session, an I²C STOP is given. When sending numerous read and write commands in one communication cycle, a repeated start command must be used to string them together (since a STOP will jump out of the communication window, which is not desired).

The STOP ends the communication, RDY goes LOW, and the device will return to process a new set of data. Once this is obtained, the communication window will again become available (RDY set HIGH).

5.6 Address-Command Description

In the address-commands, the length of the available data is often relative to the total Rx and Tx channels configured on the device. To indicate the length of these address-commands, the terms *TotalTxs* and *TotalRxs* will be used.

Most of the commands allow the master to Read/Write certain data. However in normal operation initially only the XY Data Read is recommended, since it gives a good summary of all required data. The other address-commands should only be used for setup/configuration, or when needed.

Note: For the IQS525 and IQS512 platforms often the upper byte of 2byte data will never be used. However these upper bytes are still present to maintain compatibility.

5.6.1 Version Information Read (0x00)

Here device version information can be obtained. A Product Number (2 bytes), Project Number (2 bytes), Major Release Number (1 byte) and Minor Release / Build Number (1 byte) are available, followed by a Hardware ID, and Hardware Revision (2 bytes each). A total of 10 bytes are thus available.

5.6.2 XY Data Read (0x01)

The **default** address-command at the start of each communication window is set to the XY



data read address-command. This means that if a *Current Address Read* is performed at the start of the communications window without having set the address-command before this, then the XY Data will be obtained. The XY data consists of the status byte and the following repeated sets of data bytes, relative to the number of multi-touch points used. Currently 5 points are implemented, and thus a total of (7x5 + 1) 36 bytes are available to be read in XY Data Read mode.

Table 5.2 XY Data

Byte No.	Data	Description
1	XY Info Byte	Status bytes, and indicates the total number of active co-ordinates
2 / 9 / 16 ...	ID Tag	Identify a specific co-ordinate
3 / 10 / 17 ...	Xpos – High Byte	X Position
4 / 11 / 18 ...	Xpos – Low Byte	
5 / 12 / 19 ...	Ypos – High Byte	Y Position
6 / 13 / 20 ...	Ypos – Low Byte	
7 / 14 / 21 ...	Touch Strength – High Byte	Touch Strength – indicates the ‘hardness’ of this touch
8 / 15 / 22 ...	Touch Strength – Low Byte	

XYInfoByte								
Bit	7	6	5	4	3	2	1	0
Name	SHOW_RESET	MODE_INDICATOR	NOISE_STATUS	LP_STATUS	SNAP_OUTPUT	NO_OF_FINGERS		

Bit 7: **SHOW_RESET:** This bit can be monitored to determine whether a reset occurred on the device after the **ACK_RESET** was last sent. The value of **SHOW_RESET** can be set to ‘0’ by writing a ‘1’ in the **ACK_RESET** bit.

0 = No reset has occurred since last cleared by ACK_RESET command

1 = Reset has occurred

Bit 6: **MODE_INDICATOR:** This shows in which mode the device currently is (only required in Auto Mode)

0 = Normal Mode Charging

1 = ProxMode Charging

Bit 5: **NOISE_STATUS:** This bit indicates the presence of RF noise interference.

0 = No noise detected

1 = Noise detected (noise affected outputs are not used on-chip)



- Bit 4:** **LP_STATUS:** This bit indicates if the charging is at full-speed, or low-power
 0 = full speed charging
 1 = low-power charging
- Bit 3:** **SNAP_OUTPUT:** This bit indicates if any snap outputs are active
 0 = No active snap outputs
 1 = At least one snap output
- Bit 2-0** **NO_OF_FINGERS:** Indicates how many active XY data points (number of touches + hovers) there currently are.

5.6.3 Proximity Status Read (0x02)

The proximity of each individual channel can be retrieved from the IC. After writing the 'Proximity Status' address-command, a read can be performed to obtain the proximity

bytes. The proximity of each channel found for a corresponding Tx can be obtained from two bytes. This gives a total number of proximity bytes of $2 \times TotalTxs$.

Table 5.3 Proximity Status Bytes

Byte	Data	Description
1	Prox[Tx0] – High Byte	Proximity bits (Rx0 = bit0, Rx1 = bit1 ...)
2	Prox[Tx0] – Low Byte	
3	Prox[Tx1] – High Byte	Proximity bits (Rx0 = bit0, Rx1 = bit1 ...)
4	Prox[Tx1] – Low Byte	
.	.	.
.	.	.
(2 x TotalTxs) - 1	Prox[Last Tx] – High Byte	Proximity bits (Rx0 = bit0, Rx1 = bit1 ...)
(2 x TotalTxs)	Prox[Last Tx] – Low Byte	

5.6.4 Touch Status Read (0x03)

The touch status of each individual channel can also be retrieved from the IC, exactly the same as the proximity status. After writing the 'Touch Status' address-command, a read can be performed to obtain the touch bytes.

The touch of each channel found for a corresponding Tx can be obtained from two bytes. This gives a total number of touch bytes of $2 \times TotalTxs$.



Table 5.4 Touch Status Bytes

Byte	Data	Description
1	Touch[Tx0] – High Byte	Touch bits (Rx0 = bit0, Rx1 = bit1 ...)
2	Touch [Tx0] – Low Byte	
3	Touch [Tx1] – High Byte	Touch bits (Rx0 = bit0, Rx1 = bit1 ...)
4	Touch [Tx1] – Low Byte	
:	:	:
(2 x TotalTx) - 1	Touch [Last Tx] – High Byte	Touch bits (Rx0 = bit0, Rx1 = bit1 ...)
(2 x TotalTx)	Touch [Last Tx] – Low Byte	

5.6.5 Count Data Read (0x04)

When this address-command is setup, all the count values can be read from the device. Each consists of 2 bytes, giving a total of (2 x TotalTx x TotalRx) bytes available. This will most likely be a large amount of data, and to obtain better response rate, it is NOT recommended to read this continuously.

Normally this is only read while setting up the ATI parameters.

The count values are written out, high byte first, row by row. Thus all of the first row's (Tx) count values are sent, then the second, and so on.

Table 5.5 Count Value Bytes

Byte	Data	Description
1	Count Value[0][0] – High Byte	count @ first row, and first column (thus top left)
2	Count Value[0][0] – Low Byte	
3	Count Value[0][1] – High Byte	count @ first row, and 2nd column
4	Count Value[0][1] – Low Byte	
:	:	:
(2 x TotalTx x TotalRx) - 1	Count Value[Last Tx][Last Rx] – High Byte	count @ last row, and last column (thus bottom right)
2 x TotalTx x TotalRx	Count Value[Last Tx][Last Rx] – Low Byte	



5.6.6 Long-Term Average Data Read (0x05) Average consists of 2 bytes, giving a total of $(2 \times TotalTx \times TotalRx)$ bytes available.

All the Long-Term Averages are available to be read from the device. Each Long-Term The Long-Term Averages are read in the same order as the count values, from top left (row 0 and column 0), row by.

Table 5.6 Long-Term Average Bytes

Byte	Data	Description
1	LTA[0][0] – High Byte	LTA @ first row, and first column (thus top left)
2	LTA [0][0] – Low Byte	
3	LTA [0][1] – High Byte	LTA @ first row, and 2nd column
4	LTA [0][1] – Low Byte	
:	::	:
$(2 \times TotalTx \times TotalRx) - 1$	LTA[Last Tx][Last Rx] – High Byte	LTA @ last row, and last column (thus bottom right)
$2 \times TotalTx \times TotalRx$	LTA[Last Tx][Last Rx] – Low Byte	

5.6.7 ATI Compensation Read & Write (0x06)

To read/write each channels ATI Compensation setting, a read/write must be performed after setting up the corresponding address-command to the IC. Each channels' ATI Compensation consists of 1 byte, giving a total of $(TotalTx \times TotalRx)$ bytes to read/write to/from the device. Again the channels are read/written from Tx0, Rx0, row by row down to the bottom right corner. This is however a lengthy process of configuring the ATI Compensation and the Auto-ATI is recommended (using a target value and allowing the device to automatically setup the ATI Compensation to obtain that target).

the address-command, two bytes must be written, firstly PORTB, followed by PORTD. Not all of these are available on the smaller platforms.

Table 5.7 Outputs

Tx	Port	Tx	Port
Tx0	D0	Tx8	B0
Tx1	D1	Tx9	B1
Tx2	D2	Tx10	B2
Tx3	D3	Tx11	B3
Tx4	D4	Tx12	B4
Tx5	D5	Tx13	B5
Tx6	D6	Tx14	B6
Tx7	D7	~	~

5.6.8 Port Control (0x07)

Tx's not used for sensing can be used as general purpose outputs. Clearly they are limited to being switched during the communication window. The 15 Tx's map to I/Os as shown in the table below. After setting



5.6.9 Snap Status Read (0x08)

The snap status of each individual channel can also be retrieved (if Snap functionality is

enabled), exactly the same as the proximity and touch status bits.

Table 5.8 Snap Status Bytes

Byte	Data	Description
1	Snap[Tx0] – High Byte	Snap bits (Rx0 = bit0, Rx1 = bit1 ...)
2	Snap [Tx0] – Low Byte	
3	Snap [Tx1] – High Byte	Snap bits (Rx0 = bit0, Rx1 = bit1 ...)
4	Snap [Tx1] – Low Byte	
:	:	:
(2 x TotalTx) - 1	Snap [Last Tx] – High Byte	Snap bits (Rx0 = bit0, Rx1 = bit1 ...)
(2 x TotalTx)	Snap [Last Tx] – Low Byte	

5.6.10 Control Settings (0x10)

To send the data relating to certain control commands, the *Control Settings* address-

command must be used. Two bytes follow the address-command, namely *ControlSettings0* and *ControlSettings1*.

ControlSettings0								
Bit	7	6	5	4	3	2	1	0
Name	ACK_RESET	AUTO_MODES	SINGLE_XY	PM_RESEED	MODE_SELECT	AUTO_ATI	TRACKPAD_RESEED	EVENT_MODE
Default	0	0	0	0	0	0	0	0

Bit 7: **ACK_RESET:** Acknowledge 'Indicate Reset' bit

0 = Nothing

1 = Clears the flag **SHOW_RESET** in the **XY Info Byte**

This is used to be able to notice if an unexpected reset has occurred. After setting up the device, the master can clear the SHOW_RESET flag to confirm the device is correctly setup. If the SHOW_RESET bit ever becomes set, the master will know a reset has occurred, which would mean the device must again be setup with the necessary parameters.



- Bit 6:** **AUTO_MODES:** Automatic mode switching between ProxMode and Normal Charging Mode
0 = Mode is decided by the MODE_SELECT bit
1 = Mode is automatically controlled
- Bit 5:** **SINGLE_XY:** Switching between multi-touch output to single XY output
0 = Multi-touch detection done on trackpad area
1 = Single touch output from all trackpad data (only on IQS525/512)
- Bit 4:** **PM_RESEED:** Reseed the ProxMode (PM) channel
0 = Do not reseed Long-Term Average
1 = Reseed Long-Term Average with current environment
Note: This only executes (once) after the communication window is completed.
- Bit 3:** **MODE_SELECT:** Select charging mode (if AUTO_MODES is not set)
0 = Normal Mode channels charging
1 = ProxMode channel charging
- Bit 2:** **AUTO_ATI:** Begin Automatic ATI Compensation routine
0 = No nothing
1 = Begin Auto-ATI routine (affected channels depending on current mode)
The AUTO-ATI bit must be sent ONCE to begin the AUTO-ATI routine. The ATI Compensation will be setup so that each target is close to the respective ATI Target value selected. The bit clears automatically on chip. This bit will then configure the ATI compensation relative to the current mode selected; for example if the system is in ProxMode, then the PM ATI Target will be used, and the ProxMode channel will be configured, similarly the normal mode channels will be configured if this is the current mode.
Note: This routine only executes after the communication window is completed. Also the following communication cycle will occur after the routine is completed.
- Bit 1:** **TRACKPAD_RESEED:** Reseed all the Normal Mode channels
0 = No not reseed Long-Term Average
1 = Reseed Long-Term Average with current environment
Note: The RESEED bit for both the trackpad and the ProxMode must be sent only ONCE to reseed the Long-Term Averages, the bit clears automatically on chip. This reseed only executes after the communication window is completed.
- Bit 0:** **EVENT_MODE:** Skip communication when no user activity is present
0 = Normal communication / each cycle
1 = Communication aborted until selectable activity (prox/touch/snap) is detected, or the master forces communication



ControlSettings1								
Bit	7	6	5	4	3	2	1	0
Name	DIS_PROX_EVENT	DIS_TOUCH_EVENT	DIS_SNAP_EVENT	DIS_PMPROX_EVENT	REVERSE_EN	SLEEP_EN	LOW_POWER	SNAP_EN
Default	0	0	0	0	0	0	0	0

- Bit 7:** **DIS_PROX_EVENT:** Remove proximity from Event Mode events
 0 = Proximity on Normal Mode channels will trigger the Event Mode
 1 = Proximity cannot trigger the Event Mode
- Bit 6:** **DIS_TOUCH_EVENT:** Remove touch from Event Mode events
 0 = Touch will trigger the Event Mode
 1 = Touch cannot trigger the Event Mode
- Bit 5:** **DIS_SNAP_EVENT:** Remove snap from Event Mode events
 0 = Snap will trigger the Event Mode
 1 = Snap cannot trigger the Event Mode
- Bit 4:** **DIS_PMPROX_EVENT:** Remove proximity from Event Mode events
 0 = Proximity on ProxMode channel will trigger the Event Mode
 1 = Proximity cannot trigger the Event Mode
- Bit 3:** **REVERSE_EN:** Sense proximity changes in BOTH directions
 0 = Allow only positive deltas in Projected-, and negative deltas in self-capacitive setting to trigger proximity output
 1 = Positive and negative deltas can trigger a proximity event
- Bit 2:** **SLEEP_EN:** Add a permanent sleep interval to each system cycle in Normal Mode
 0 = Normal operation
 1 = Permanent sleep time added (according to the selected *SleepTime*)
- Bit 1:** **LOW_POWER:** Low Power charging selection
 0 = Normal Power charging / full-speed
 1 = Low Power charging (according to the selected *LPTime*)
- Bit 0:** **SNAP_EN:** Enable calculating Snap status
 0 = Snap calculating is disabled
 1 = Snap calculating is enabled

5.6.11 Threshold Settings (0x11)

All the thresholds are setup through this address-command. This includes both the XY touch panel channels, as well as the

ProxMode channels. The meaning of these bytes are covered in Section 3.11, Section 3.12 and Section 3.13. The relative bytes are shown in the tables below:



Table 5.9 Threshold Settings Bytes

Byte	Data	Applicable channels	Description	Default Value
1	ProxThreshold	Thresholds applied to trackpad channels (falling within the selected <i>TrackpadTx</i> and <i>TrackpadRx</i> block)	Delta value used for proximity threshold	10
2	TouchThresholdMult		Touch Threshold Multiplier	5
3	TouchThresholdShift		Touch Threshold Shifter	7
4	PM ProxThreshold	ProxMode channel	Delta value used for proximity threshold of ProxMode channels	10
5	Snap Threshold – High Byte	All channels (not including ProxMode)	Delta value BELOW LTA where a SNAP is decided	100
6	Snap Threshold – Low Byte			
7	ProxThreshold2	Thresholds applied to non-trackpad channels (falling outside the selected <i>TrackpadTx</i> and <i>TrackpadRx</i> block and within the <i>TotalRx</i> and <i>TotalTx</i> block)	Delta value used for proximity threshold	10
8	TouchThresholdMult2		Touch Threshold Multiplier	5
9	TouchThresholdShift2		Touch Threshold Shifter	7

5.6.12 ATI Settings (0x12)

To configure the ATI parameters relating to the XY trackpad channels, and a second set for non-trackpad channels, this address-command can be used. Here the ATI Target can be set (which is then used together with

the Auto-ATI routine) to configure the ATI Compensation on each channel. An ATI C value can also be configured here for the entire touch panel. The bytes to be written are shown below.



Table 5.10 ATI Settings Bytes

Byte	Data	Applicable channels	Description	Default
1	ATI Target – High Byte	ATI settings applied to trackpad channels (falling within the selected <i>TrackpadTx</i> and <i>TrackpadRx</i> block)	Target value for Count values, obtained by changing ATI compensation parameter (sensitivity)	600
2	ATI Target – Low Byte			
3	ATIC			
4	ATI Target – High Byte	ATI settings applied to non-trackpad channels (falling outside the selected <i>TrackpadTx</i> and <i>TrackpadRx</i> block and within the <i>TotalRx</i> and <i>TotalTx</i> block)	Target value for Count values, obtained by changing ATI compensation parameter (sensitivity)	600
5	ATI Target – Low Byte			
6	ATIC			

5.6.13 Filter Settings (0x13)

The various settings relating to the on-chip filters can be adjusted / configured here. All these filters can be disabled if not required. Also, the damping factors (amount of filtering) can be adjusted for these independently. This is because the hover requires more filtering, whereby the touch points have either a static or dynamic filter implementation. The

damping parameter for the touch and hover co-ordinate, and ProxMode count filters are used as this value/256. The normal mode count filter damping value is $1/2^{\text{value}}$. The smaller these fractions, the MORE filtering will occur. More filtering provides stable data at the cost of responsiveness. The bytes and definitions are provided.



Table 5.11 Filter Settings Bytes

Byte	Data	Description	Default Value
1	FilterSettings0	Numerous filter settings	0x00
2	Touch Filter Damping Value	Adjust the amount of filtering applied to the XY touch points	128 (128/256)
3	Hover Filter Damping Value	Adjust the amount of filtering applied to the XY hover points	38 (128/256)
4	PM Count Filter Damping Value	Adjusts the amount of filtering applied to the ProxMode count value	16 (128/256)
5	LP PM Count Filter Damping Value	Adjusts the amount of filtering applied to the ProxMode count value – In Low-Power charging	128 (128/256)
6	NM Count Filter Damping Value	Adjusts the amount of filtering applied to the normal mode count values	3 (1/2 ³)

FilterSettings0								
Bit	7	6	5	4	3	2	1	0
Name				DIS_NM_FILTER	DIS_PM_FILTER	SELECT_TOUCH_FILTER	DIS_HOVER_FILTER	DIS_TOUCH_FILTER
Default	-	-	-	-	0	0	0	0

Bit 7-5: *Unused*

Bit 4: **DIS_NM_FILTER:** Disable Normal Mode count value filter

0 = Filter enabled

1 = Filter disabled

Bit 3: **DIS_PM_FILTER:** Disable ProxMode count value filter

0 = Filter enabled

1 = Filter disabled

Bit 2: **SELECT_TOUCH_FILTER:** Select the type of filtering for the touch co-ordinates

0 = Dynamic filter (variable damping factor relative to XY motion)

1 = Static filter (fixed but configurable damping factor)

Bit 1: **DIS_HOVER_FILTER:** Disable filtering on hover co-ordinates

0 = Hover filtering enabled

1 = Hover filtering disabled



Bit 0: **DIS_TOUCH_FILTER:** Disable filtering on touch co-ordinates
0 = Touch filtering enabled
1 = Touch filtering disabled

5.6.14 Timing Settings (0x14)

On-chip timings can be adjusted here, and are explained below.

Reseed Time

The reseed time is the time that a channel allows a prox/touch to continually be set, before assuming it is a fault condition. Once this time has elapsed, a reseed is forced to correct the condition. In Normal Mode, all the channels (not including the ProxMode channel) are reseeded. For the default value, if a prox/touch is seen anywhere on the touch panel for 40s, a global reseed will be executed to remove this assumed stuck condition. It is recommended to make this timeout quite long, since it is unpleasant to have the device reseed while drawing on the panel. The master can however still send the Reseed command anytime when fault conditions relative to the application are assumed.

When this occurs in ProxMode, only the ProxMode channel is reseeded.

The configurable value works in multiples of 500ms, thus the default value of 80, will select a *ReseedTime* of 40s.

Comms Timeout

This is a timer that monitors the activity on the I²C bus. If there is no successful read/write this within this time a timeout will occur, and the communication window will close, resuming sensing.

This assists in overcoming any stuck conditions caused by errors on the I²C bus. It can also be used as a RDY timeout, thus if the master cannot always service the communication, and does not mind missing a

cycle's data, then the RDY will only be high for the *Comms Timeout* time, and then it will go low, and the cycle will continue.

Mode Time

This timer is responsible for the timings used when implementing the Automatic Mode control, and also the low-power timings. The value used here is also a multiple of 500ms. For more details see Section 3.4 and Section 3.5

Low-Power Time

Here the low-power timing can be adjusted. Predetermined intervals can be selected here to configure how long the device will sleep between data acquisitions in the Low-Power charging mode. Clearly the longer the sleep time, the lower the power consumption will be, at the expense of response time. Typically the ProxMode channel will be setup to provide a good distance proximity. This will give the device enough time to be up and running before the user interacts with the trackpad channels, even if the *LPTime* is selected to be reasonably long.

Sleep Time

This is a sleep interval that is permanently added to each cycle in Normal Mode, unlike the Low-Power which is only added under certain conditions (for example if no prox/touch is sensed). This can be used in current sensitive designs, where a rapid response rate is not crucial. For example, if a normal cycle took ~10ms in total, then adding a 10ms *SleepTime* could almost halve the total current consumption. This would add to any Low-Power timing.



Table 5.12 Timing Settings Bytes

Byte	Data	Description	Default Value
1	ReseedTime	Stuck prox/touch condition timer	80 (thus 40s)
2	CommsTimeout	Timer monitoring the I ² C activity	100 (ms)
3	ModeTime	Mode timer (Mode switching, and Low-Power switching)	8 (thus 4s)
4	LPTime	Low-Power timing	8 ^{Note1} (~160ms)
5	SleepTime	Permanent sleep timing	3 ^{Note1} (~5ms)

Note1: Both of these values are translated to the time interval, as depicted in Table 5.13.

Table 5.13 LPTime and SleepTime Selections

Value	Time	Value	Time
1	1 ms	7	80 ms
2	2 ms	8	160 ms
3	5 ms	9	320 ms
4	10 ms	10	640 ms
5	20 ms	11	1.2 s
6	40 ms	12	2.4 s
		13	5 s

Note: These are only approximate values, and must not be used for time critical applications.

5.6.15 Channel Setup (0x15)

The amount of Rx's and Tx's used for trackpad (XY information) purposes, as well as the total Rx and Tx's used can be selected. Note that many of the data packets are variable in length relative to how many Rx's

and Tx's are used. Thus once these are changed, remember that the amount of data available under certain address-commands could also change.



Table 5.14 Channel Setup Bytes

Byte	Data	Description	Default Value		
			IQS550	IQS525	IQS512
1	TotalRxs	Total amount of Rx channels used	10	5	4
2	TotalTxS	Total amount of Tx channels used	15	5	3
3	TrackpadRxs	Total amount of Rx channels used for XY trackpad purposes	10	5	4
4	TrackpadTxS	Total amount of Tx channels used for XY trackpad purposes	15	5	3
5	PMSetup0	ProxMode settings, and Rx configuration	40 (hex)	0	0
6	TxHigh	ProxMode Tx configuration	7F (hex)	0	0
7	TxLow		FF (hex)	1F (hex)	07 (hex)

PMSetup0								
Bit	7	6	5	4	3	2	1	0
Name	CHARGE_TYPE	RX_GROUP (only on IQS550)	~	SUM_OF_TP (only on IQS512/525)	RX_SELECT			
Default	0	1	0	0	0	0	0	0

Bit 7: **CHARGE_TYPE:** Select ProxMode method of charging

- 0 = Projected/Mutual Capacitive Charging
- 1 = Self Capacitive Charging

Bit 6: **RX_GROUP:** Select RxA or RxB for ProxMode channel electrode

- 0 = ProxMode channel is from RxA group
- 1 = ProxMode channel is from RxB group

Bit 5: *Unused*

Bit 4: **SUM_OF_TP:** Configure ProxMode channel as sum of trackpad channels

- 0 = ProxMode channel defined by RX_SELECT and TxHigh:TxLow
- 1 = ProxMode is sum of Rx's falling within selected *TrackpadRxs*. CHARGE_TYPE and TxHigh:TxLow still select as usual.

Bit -0-3: **RX_SELECT:** Select individual Rx electrode for ProxMode

- 0 – 9 = Decimal value translates to Rx0 to Rx9



TxHigh ⁽¹⁾								
Bit	7	6	5	4	3	2	1	0
Name	~	PM_TX14	PM_TX13	PM_TX12	PM_TX11	PM_TX10	PM_TX9	PM_TX8
Default	0	1	1	1	1	1	1	1

Bit 7: Unused

Bit 6-0: **PM_TX**: Select active Tx's for ProxMode

0 = Disabled

1 = Enabled

TxLow ⁽¹⁾								
Bit	7	6	5	4	3	2	1	0
Name	PM_TX7	PM_TX6	PM_TX5	PM_TX4	PM_TX3	PM_TX2	PM_TX1	PM_TX0
Default	1	1	1	1	1	1	1	1

Bit 7-0: **PM_TX**: Select active Tx's for ProxMode

0 = Disabled

1 = Enabled

Note1: If self capacitive charging is selected, the Rx channel is used and the Tx selection is redundant.

5.6.16 Hardware Config Settings (0x16)

Settings specific to the ProxSense® Module charge transfer characteristics can be changed. **It is however unlikely that the designer will change these values from the default settings, and thus they are just briefly mentioned.**

A few settings that might be required: ProxSettings0<NOISE_EN>. This is the on-chip noise detection. It can be enabled and disabled here (0=disabled, 1=enabled).

The ProxSense® charge transfer frequency can be setup here by changing the UPLEN and PASSLEN parameters. The charge transfer frequency (f_{cc}) can be calculated as:

$$f_{cc} = \frac{16.10^6}{(2^{(7-CK_FREQ)}) \times (2 + UP + PASS + INC_PHASE)}$$

where

$$UP = 2^{(UPLEN-2)} \quad (\text{if } UPLEN > 4)$$

$$UP = UPLEN \quad (\text{if } UPLEN \leq 4)$$

$$PASS = 2^{(PASSLEN-2)} \quad (\text{if } PASSLEN > 4)$$

$$PASS = PASSLEN \quad (\text{if } PASSLEN \leq 4)$$

Note: CK_FREQ, UPLEN and PASSLEN are the numerical value of the settings

For example the default frequency is:

$$f_{cc} = \frac{16.10^6}{(2^{(7-7)}) \times (2 + 4 + 3 + 0)} = 1.77MHz$$



Table 5.15 Prox Hardware Config

Byte	Data	Description	Default Value
1	ProxSettings0	Prox Module Settings Byte 0	0x24
2	ProxSettings1	Prox Module Settings Byte 1	0x72
3	ProxSettings2	Prox Module Settings Byte 2	0x15
4	ProxSettings3	Prox Module Settings Byte 3	0x43

ProxSettings0								
Bit	7	6	5	4	3	2	1	0
Name	~	~	NOISE_EN	~	~	CXVSS	SYNC_EN	SYNC_EDGE
Default	0	0	1	0	0	1	0	0

ProxSettings1								
Bit	7	6	5	4	3	2	1	0
Name	MODULE_LP	CK_FREQ<2:0>			~	~	ANA_DEAD	INC_PHASE
Default	0	1	1	1	0	0	1	0

ProxSettings2								
Bit	7	6	5	4	3	2	1	0
Name	STBL_1	STBL_0	OP_BIAS1	OP_BIAS0	TRIP3	TRIP2	TRIP1	TRIP0
Default	0	0	0	1	0	1	0	1

ProxSettings3								
Bit	7	6	5	4	3	2	1	0
Name	~	UPLEN2	UPLEN1	UPLEN0	~	PASSLEN2	PASSLEN1	PASSLEN0
Default	0	1	0	0	0	0	1	1



5.6.17 Active Channels (0x17)

0 = Disabled
1 = Enabled

Here individual channels can be disabled. By clearing the relative bit in the Active Channels byte a channel disable is achieved.

Table 5.16 Active Channel Bytes

Byte	Data	Description	Default		
			IQS550	IQS525	IQS512
1	ActiveChannels[Tx0] – High Byte	Active Channels bits (Rx0 = bit0, Rx1 = bit1 ...)	0x3FF	0x01F	0x00F
2	ActiveChannels [Tx0] – Low Byte				
3	ActiveChannels [Tx1] – High Byte	Active Channels bits (Rx0 = bit0, Rx1 = bit1 ...)	0x3FF	0x01F	0x00F
4	ActiveChannels [Tx1] – Low Byte				
:	:	:	0x3FF	0x01F	0x00F
(2 x TotalTx) - 1	ActiveChannels [Last Tx] – High Byte	Active Channels bits (Rx0 = bit0, Rx1 = bit1 ...)	0x3FF	0x01F	0x00F
(2 x TotalTx)	ActiveChannels [Last Tx] – Low Byte				

5.6.18 Debounce Settings (0x18)

The debounce parameters of the channel outputs can be configured here.

Table 5.17 Debounce Value Bytes

Byte	Data	Description	Default
1	ProxDb	Proximity debounce values	0x44 (Db = 4)
2	TouchSnapDb	Touch and snap debounce values	0x44 (Touch db = 0 Snap db = 1)



ProxDdb								
Bit	7	6	5	4	3	2	1	0
Name	Prox Set Debounce				Prox Clear Debounce			
Default	0	1	0	0	0	1	0	0

TouchSnapDb								
Bit	7	6	5	4	3	2	1	0
Name	Click Set Debounce		Touch Set Debounce		Click Clear Debounce		Touch Clear Debounce	
Default	0	1	0	0	0	1	0	0

5.6.19 ProxMode Proximity Status (0x20)

The proximity of the ProxMode channel can be obtained here.

Table 5.18 PM Proximity Status Bytes

Byte	Data	Description
1	PM Prox Byte	0 = No Prox / 1 = ProxMode Channel Prox

5.6.20 ProxMode Count Data Read (0x21)

When this address-command is setup, the count value for the ProxMode channel can be read.

The count value consists of 2 bytes. Normally this is only read while setting up the ATI parameters

Table 5.19 ProxMode Count Values

Byte	Data	Description
1	PM Count Value – High Byte	ProxMode count value for self capacitive prox channel
2	PM Count Value – Low Byte	

5.6.21 ProxMode Long-Term Average Read (0x22)

When this address-command is the Long-Term-Average for the ProxMode channel can

be read. The Long-Term Average again consists of 2 bytes.



Table 5.20 PM Long-Term Average Bytes

Byte	Data	Description
1	PM Long-Term Average – High Byte	ProxMode Long-Term Average for self capacitive prox channel
2	PM Long-Term Average – Low Byte	

5.6.22 ProxMode ATI Compensation Read/Write (0x23) 5.6.23 ProxMode ATI Settings (0x24)

To read or write the ProxMode channels' ATI Compensation value, a read/write must be performed after setting up the corresponding address-command. Configuring the ATI Compensation manually is however a lengthy process and the Auto-ATI routine is recommended. The ATI Compensation is a single byte.

To configure the ProxMode ATI parameters, this address-command can be used. Here the ATI target can be configured (which is then used together with the Auto-ATI routine) to configure the ATI Compensation on the ProxMode channel. An ATI C value can also be configured for the ProxMode channel. The bytes to be written are shown below.

Table 5.21 ATI Settings Bytes

Byte	Data	Description	Default Value
1	PM ATI Target – High Byte	Target value for Count values, obtained by changing ATI compensation parameter (sensitivity)	500
2	PM ATI Target – Low Byte		
3	PM ATIC	ATI C value	0 (values from 0 to 31)



6 Circuit Diagram

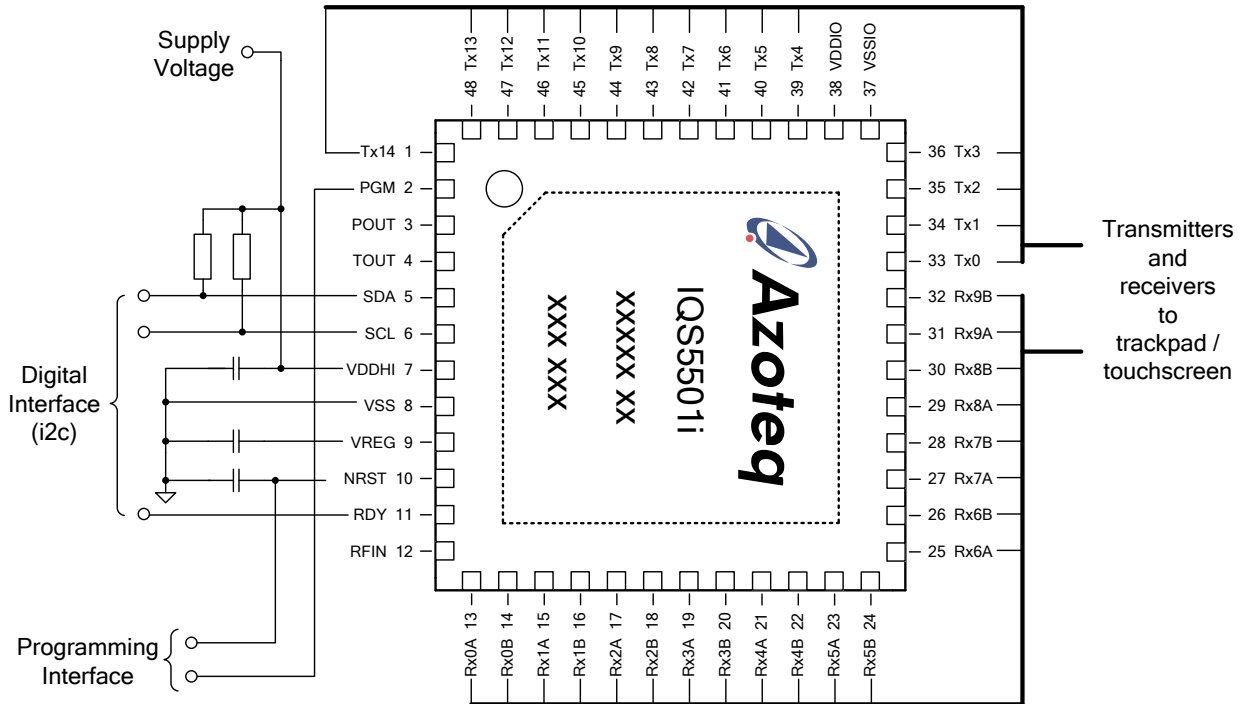

Figure 6.1 IQS550 Overview Diagram

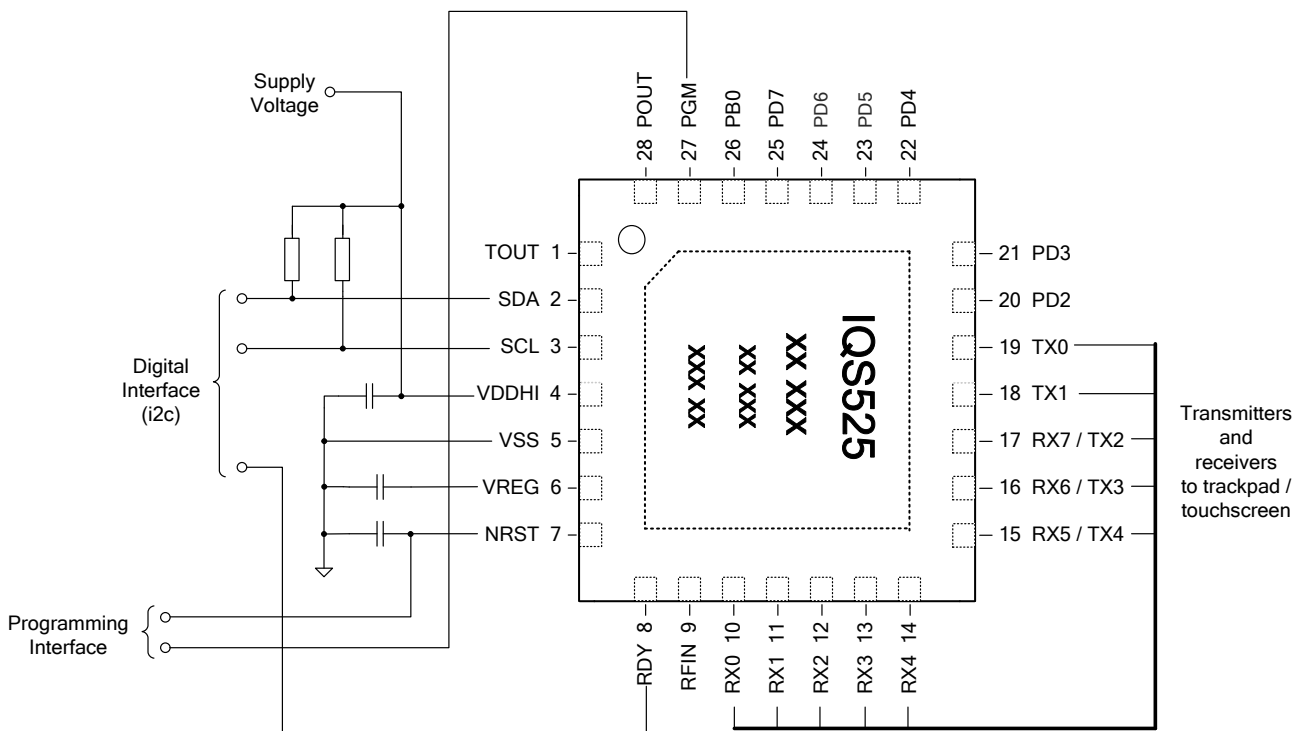

Figure 6.2 IQS525 Overview Diagram

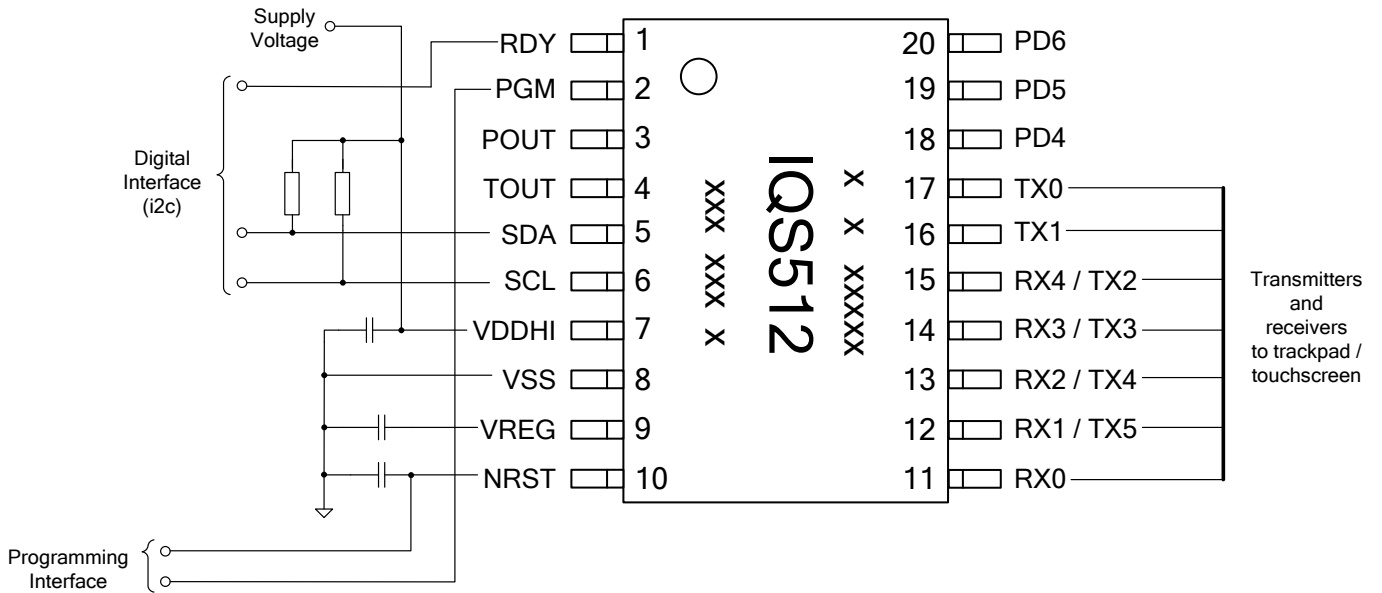
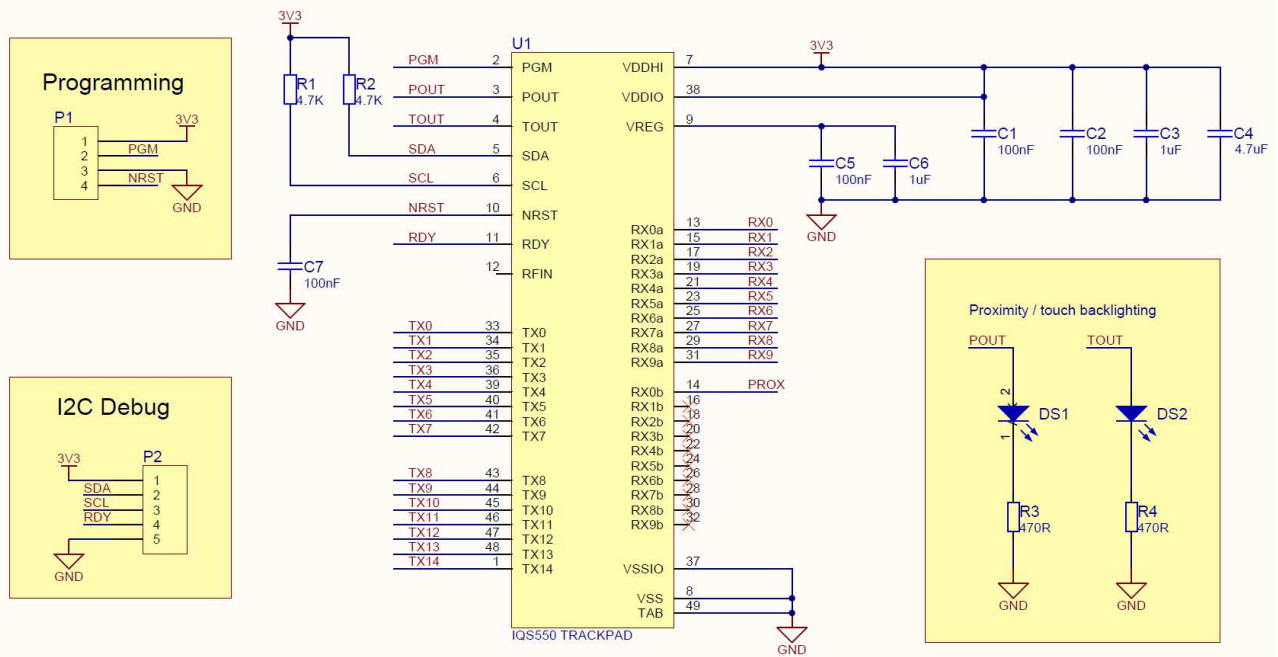

Figure 6.3 IQS512 Overview Diagram



Representation of pattern layout:

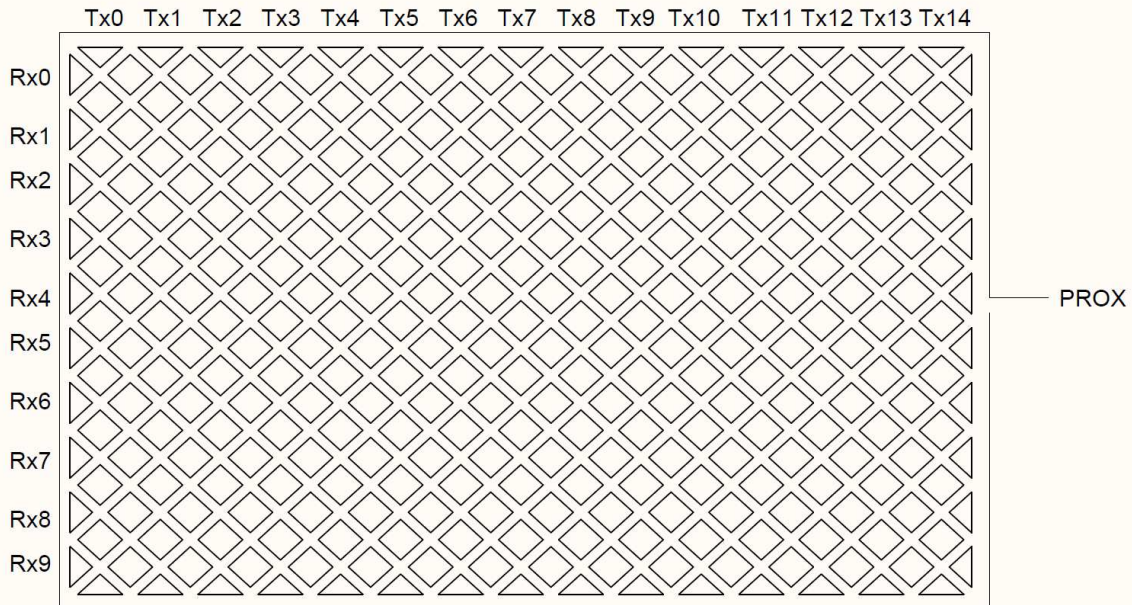

Figure 6.4 IQS550 Application Circuit

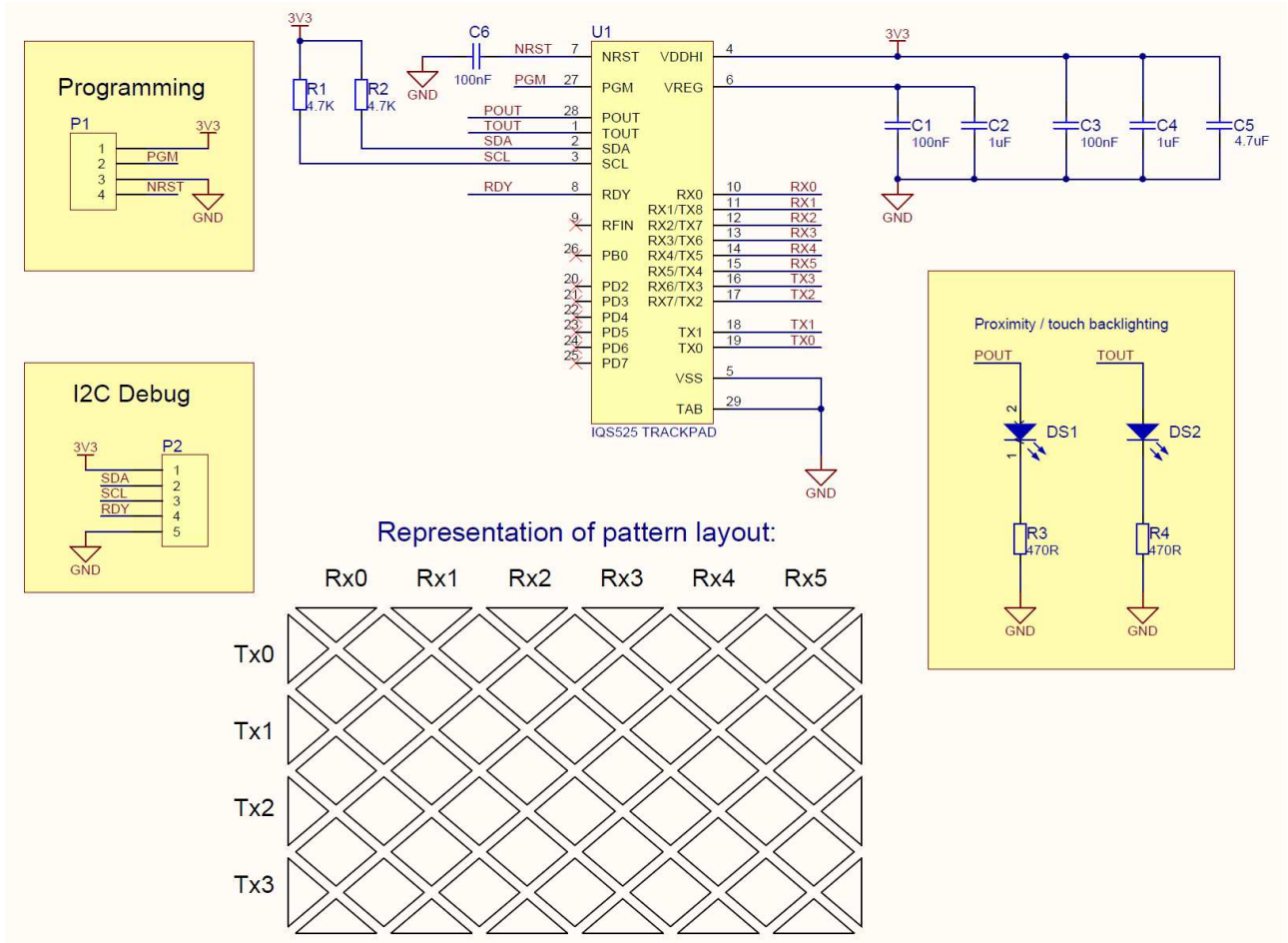

Figure 6.5 IQS525 Application Circuit

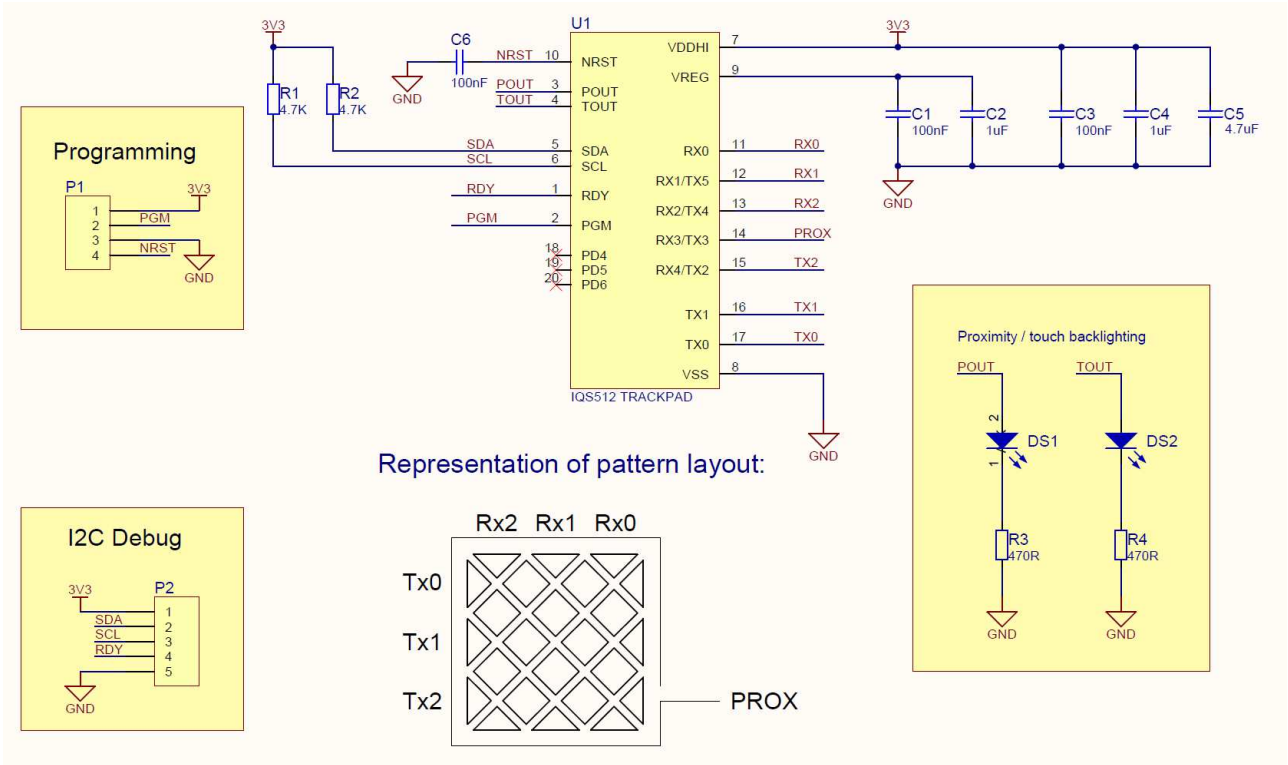

Figure 6.6 IQS512 Application Circuit



7 Electrical Characteristics

7.1 Absolute Maximum Ratings

Exceeding these maximum ratings may cause permanent damage to the device.

Table 7.1 Voltage Characteristics

Symbol	Rating	Min	Max	Unit
$V_{DDHI} - V_{SS}$	External supply voltage	-0.3	4.0	V
V_{IN}	Receiver channel pins (Rx0A...Rx9B)	$V_{SS}-0.3$	$V_{REG} (-1.55)$	
	Input voltage on transmit pins (Tx0...Tx14)	PXS off	4.0	
		PXS on ⁽¹⁾	$V_{REG} (-1.55)$	
	Input voltage on any pin ⁽²⁾	$V_{SS}-0.3$	4.0	

1. If the ProxSense[®] peripheral is on, no injection must be performed on any pin having the transmit function (Tx) as an alternate function, even if this alternate function is not specified
2. $I_{INJ(PIN)}$ must never be exceeded. This is implicitly insured if V_{IN} maximum is respected. If V_{IN} maximum cannot be respected, the injection current must be limited externally to the $I_{INJ(PIN)}$ value. A positive injection is induced by $V_{IN}>V_{DDHI}$ while a negative is induced by $V_{IN}<V_{SS}$.

Table 7.2 Current Characteristics

Symbol	Rating	Max.	Unit
I_{VDDHI}	Total current into V_{DDHI} power line (source)	80	mA
I_{VSS}	Total current out of V_{SS} ground line (sink)	80	
I_{IO}	Output current sunk by any other I/O and control pin	25	
	Output current source by any I/Os and control pin	-25	
$I_{INJ(PIN)}^{(1)}$	Injected current on any pin ⁽²⁾	±5	
$\sum I_{INJ(PIN)}^{(1)}$	Total injected current (sum of all I/O and control pins) ⁽²⁾	±25	

1. $I_{INJ(PIN)}$ must never be exceeded. This is implicitly insured if V_{IN} maximum is respected. If V_{IN} maximum cannot be respected, the injection current must be limited externally to the $I_{INJ(PIN)}$ value. A positive injection is induced by $V_{IN}>V_{DDHI}$ while a negative injection is induced by $V_{IN}<V_{SS}$. For true open-drain pads, there is no positive injection current, and the corresponding V_{IN} maximum must always be respected.
2. When several inputs are submitted to a current injection, the maximum $\sum I_{INJ(PIN)}$ is the absolute sum of the positive and negative injected currents (instantaneous values). These results are based on characterization with $\sum I_{INJ(PIN)}$ maximum current injection on four I/O port pins of the device.



Table 7.3 Thermal Characteristics

Symbol	Rating	Max.	Unit
TSTG	Storage temperature range	-65 to +150	°C
TJ	Maximum junction temperature	150	

7.2 Operating Conditions

7.2.1 General Operating Conditions

Table 7.4 General Operating Conditions

Symbol	Parameter	Conditions	Min	Typ	Max	Unit
$f_{\text{MASTER}}^{(1)}$	Master clock frequency	$1.65\text{V} \leq V_{\text{DDHI}} \leq 3.6\text{V}$	-	16	-	MHz
V_{DDHI}	Standard operating voltage	-	1.65	-	3.6	V
$P_{\text{D}}^{(2)}$	Power dissipation at $T_{\text{A}} = 85^{\circ}\text{C}$	-	-	-	625	mW
T_{A}	Temperature range	$1.65\text{V} \leq V_{\text{DDHI}} \leq 3.6\text{V}$	-40	-	85	°C
T_{J}	Junction temperature range	$-40^{\circ}\text{C} \leq V_{\text{DDHI}} \leq 85^{\circ}\text{C}$	-40	-	105	°C

1. $f_{\text{MASTER}} = f_{\text{CPU}}$

2. To calculate $P_{\text{Dmax}}(T_{\text{A}})$ use the formula given in thermal characteristics $P_{\text{Dmax}} = (T_{\text{Jmax}} - T_{\text{A}}) / \theta_{\text{JA}}$ with T_{Jmax} in this table and θ_{JA} in table "Thermal characteristics".

7.2.2 Power-up / Power-down Operating Conditions

Table 7.5 Operating conditions at power up / down

Symbol	Parameter	Conditions	Min	Typ	Max	Unit
t_{VDDHI}	V_{DDHI} rise time rate		20	-	1300	µs/V
t_{TEMP}	Reset release decay	V_{DDHI} rising	-	1	-	Ms
V_{POR}	Power on reset threshold		1.44	-	1.65 ⁽¹⁾	V
V_{PDR}	Power down reset threshold		1.30	-	1.60 ⁽²⁾	V

1. Tested in production

2. Data based on characterisation results, not tested in production.



7.2.3 Supply current characteristic

Table 7.6 Total Current Consumption⁽¹⁾

Symbol	Charging Mode	Low-Power setting	Current (Typ)			Unit
			IQS550	IQS525	IQS512	
I _{DD}	Normal Mode	LP disabled	4.20 ⁽³⁾	3.60	3.70	mA
	Normal Mode ⁽²⁾	10ms	3.30	1.85	1.30	mA
	Normal Mode ⁽²⁾	20ms	2.60	1.30	0.86	mA
	Normal Mode ⁽²⁾	40ms	2.00	0.85	0.60	mA
	Normal Mode ⁽²⁾	80ms	1.40	0.44	0.42	mA
	Normal Mode ⁽²⁾	320ms	330	320	300	uA
	ProxMode	LP disabled	1.84			mA
	ProxMode ⁽³⁾	10ms	372			uA
	ProxMode ⁽³⁾	40ms	110			uA
	ProxMode ⁽³⁾	80ms	57			uA
	ProxMode ⁽³⁾	320ms	15			uA
	ProxMode ⁽³⁾	640ms	8			uA
	ProxMode ⁽⁴⁾	640ms	10			uA

1. Based on bench measurements, not characterised
2. Tested with maximum number of sensors active (IQS550 – 15x10 / IQS525 – 5x5 / IQS512 – 4x3); ATI Target of 600 counts; Event-Mode enabled (thus no communication)
3. Tested with a ProxMode channel configured in self capacitive mode; ATI Target of 1000; and Event-Mode enabled
4. Tested with a ProxMode channel configured in projected capacitive mode (all Tx's active); ATI Target of 1000; and Event-Mode enabled



7.2.4 Report Rate

Table 7.7 Example Report Rates¹

Device	Total Rxs	Total TxS	Report Rate (Hz)		
			1 touch ²	2 touches ³	5 touches ⁴
IQS550	10	15	129	112	88
IQS550	9	12	161	137	102
IQS550	9	9	192	165	113
IQS525	5	5	333	255	-
IQS525	6	4	357	231	-
IQS525	3	3	416	300	-
IQS512	4	3	588	406	-
IQS512	3	3	625	427	-

1. Based on bench measurements, not characterised.
Tested with ATI Target of 600 counts. Only relevant amount of XY data streamed via I²C.
2. Stream 1 co-ordinates data (total of 8 bytes)
3. Stream 2 co-ordinates data (total of 15 bytes)
4. Stream 5 co-ordinates data (total of 36 bytes)

7.2.5 I/O port pin characteristics

General characteristics

Subject to general operating conditions for V_{DDHI} and T_A unless otherwise specified. All unused pins must be kept at a fixed voltage: using the output mode of the I/O for example or an external pull-up or pull-down resistor.



Table 7.8 Standard I/O Static characteristic ^{(1) (2)}

Symbol	Parameter	Conditions	Min.	Typ.	Max.	Unit
V _{IL}	Input low level voltage ⁽³⁾	Standard I/Os	V _{SS} -0.3	-	0.3V _{DDHI}	V
V _{IH}	Input high level voltage ⁽³⁾	Standard I/Os	0.7 V _{DDHI}	-	V _{DDHI} +0.3	
V _{hys}	Schmitt trigger voltage hysteresis ⁽⁴⁾	Standard I/Os	-	200	-	mV
I _{Ikg}	Input leakage current ⁽⁵⁾	V _{SS} ≤ V _{IN} ≤ V _{DDHI} Standard I/Os	-1	-	1	uA
		V _{SS} ≤ V _{in} ≤ V _{REG} ⁽⁶⁾ Rx, Tx I/Os	-1	-	1	
R _{PU}	Weak pull-up equivalent resistor ⁽⁷⁾	V _{IN} = V _{SS}	30	45	60	kΩ
C _{IO} ⁽⁸⁾	I/O pin capacitance		-	5	-	pF

1. V_{DDHI} = 3.0 V, T_A = -40 to 85°C unless otherwise specified.
2. Not applicable to Rx and Tx pins.
3. Data based on characterisation results, not tested in production.
4. Hysteresis voltage between Schmitt trigger switching levels. Based on characterization results, not tested.
5. The maximum value may be exceeded if negative current is injected on adjacent pins.
6. V_{IN} must not exceed V_{REG} value if ProxSense® is enabled, even on port B and D (Tx), V_{REG} = 1.55V.
7. R_{PU} pull-up equivalent resistor based on a resistive transistor (corresponding I_{PU} current characteristics)
8. Data guaranteed by design, not tested in production



Output driving current

Subject to general operating conditions for V_{DDHI} and T_A unless otherwise specified.

Table 7.9 Output driving current (high sink ports)

I/O type	Symbol	Parameter Conditions	Conditions	Min.	Max.	Unit
Standard	$V_{OL}^{(1)}$	Output low level voltage for an I/O pin	$I_{IO} = +2mA$, $V_{DDHI} = 1.8V$	-	0.45	V
			$I_{IO} = +2mA$, $V_{DDHI} = 3.0V$	-	0.45	
			$I_{IO} = +10mA$, $V_{DDHI} = 3.0V$	-	0.7	
	$V_{OH}^{(2)}$	Output high level voltage for an I/O pin	$I_{IO} = -1mA$, $V_{DDHI} = 1.8V$	V_{DDHI} -0.45	-	
			$I_{IO} = -1mA$, $V_{DDHI} = 3.0V$	V_{DDHI} -0.45	-	
			$I_{IO} = -10mA$, $V_{DDHI} = 3.0V$	V_{DDHI} -0.7	-	
ProxSense I/O	V_{OL}	Output low level voltage for Tx and Rx ProxSense I/Os	$I_{RX} = TBD$	-	TBD	
	V_{OH}	Output high level voltage for Tx ProxSense I/O	$I_{TX} = 1mA$	1.45	-	
	V_{OH}	Output high level voltage for Rx ProxSense I/O	$I_{PXS_RX} = 0.5mA$	1.35	-	

1. The I_{IO} current sunk must always respect the absolute maximum rating and the sum of I_{IO} (I/O ports and control pins) must not exceed I_{VSS} .
2. The I_{IO} current sourced must always respect the absolute maximum rating and the sum of I_{IO} (I/O ports and control pins) must not exceed I_{VDDHI} .

NRST pin

The NRST pin input driver is CMOS. A permanent pull-up is present, thus an external component is not needed if NRST is unconnected in the design.

Subject to general operating conditions for V_{DDHI} and T_A unless otherwise specified.

Table 7.10 NRST pin characteristics

Symbol	Parameter	Conditions	Min.	Typ.	Max.	Unit
$V_{IL(NRST)}$	NRST Input low level voltage ⁽¹⁾		V_{SS}	-	0.8	V
$V_{IH(NRST)}$	NRST Input high level voltage ⁽¹⁾		1.4	-	V_{DDHI}	
$V_{OL(NRST)}$	NRST Output low level voltage	$I_{OL} = 2mA$	-	-	$V_{DDHI} - 0.8$	
$R_{PU(NRST)}$	NRST pull-up equivalent resistor ⁽²⁾		30	45	60	kΩ
$V_{F(NRST)}$	NRST input filtered pulse ⁽³⁾		-	-	50	ns
$t_{OP(NRST)}$	NRST output pulse width		20	-	-	
$V_{NF(NRST)}$	NRST input not filtered pulse ⁽³⁾		300	-	-	

1. Data based on characterization results, not tested in production.
2. The RPU pull-up equivalent resistor is based on a resistive transistor.
3. Data guaranteed by design, not tested in production.

The reset network shown in Figure 7.1 protects the device against parasitic resets. The user must ensure that the level on the NRST pin can go below the V_{IL} max. level specified in *Table 7.10*. Otherwise the reset is not taken into account internally.

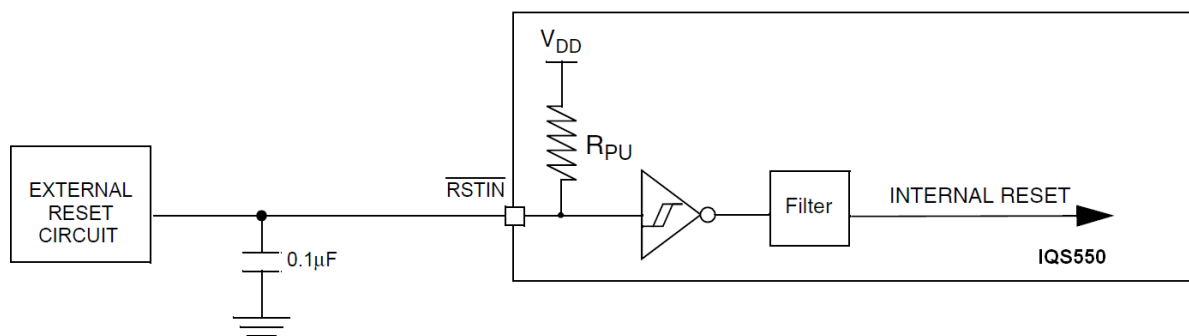

Figure 7.1 Recommended NRST pin configuration

7.2.6 Electrostatic discharge (ESD)

Electrostatic discharges (a positive then a negative pulse separated by 1 second) are applied to the pins of each sample according to each pin combination. The sample size depends on the number of supply pins in the device (3 parts*(n+1) supply pin). Two models can be simulated: human body model and charge device model. This test conforms to the JESD22-A114A/A115A standard.



Table 7.11 ESD Absolute Maximum Ratings

Symbol	Ratings	Conditions	Max Value	Unit
V _{ESD} (HBM)	Electrostatic discharge voltage (human body model)	T _A = +25 °C	2000 ⁽²⁾	V
V _{ESD} (CDM)	Electrostatic discharge voltage (charge device model)		1000	

1. Data based on characterisation results, not tested in production.
2. Device sustained up to 3000 V during ESD trials.

7.2.7 Thermal characteristics

The maximum chip junction temperature (T_{Jmax}) must never exceed the values given in Table 7.4.

The maximum chip-junction temperature, T_{Jmax}, in degrees Celsius, may be calculated using the following equation:

$$T_{Jmax} = T_{Amax} + (P_{Dmax} \times \theta_{JA})$$

Where:

- T_{Amax} is the maximum ambient temperature in °C
- θ_{JA} is the package junction-to-ambient thermal resistance in °C/W
- P_{Dmax} is the sum of P_{INTmax} and P_{I/Omax} (P_{Dmax} = P_{INTmax} + P_{I/Omax})
- P_{INTmax} is the product of I_{DD} and V_{DDHI}, expressed in watts. This is the maximum chip internal power.
- P_{I/Omax} represents the maximum power dissipation on output pins where: P_{I/Omax} = $\sum (V_{OL} \cdot I_{OL}) + \sum ((V_{DDHI} - V_{OH}) \cdot I_{OH})$, taking into account the actual V_{OL}/I_{OL} and V_{OH}/I_{OH} of the I/Os at low and high level in the application.

Table 7.12 Thermal characteristics⁽¹⁾

Symbol	Parameter	Value	Unit
θ_{JA}	Thermal resistance junction ambient	32	°C/W

1. Thermal resistances are based on JEDEC JESD51-2 with 4-layer PCB in a natural convection environment.



8 Mechanical Dimensions

8.1 IQS550 QFN(7x7)-48 Mechanical Dimensions

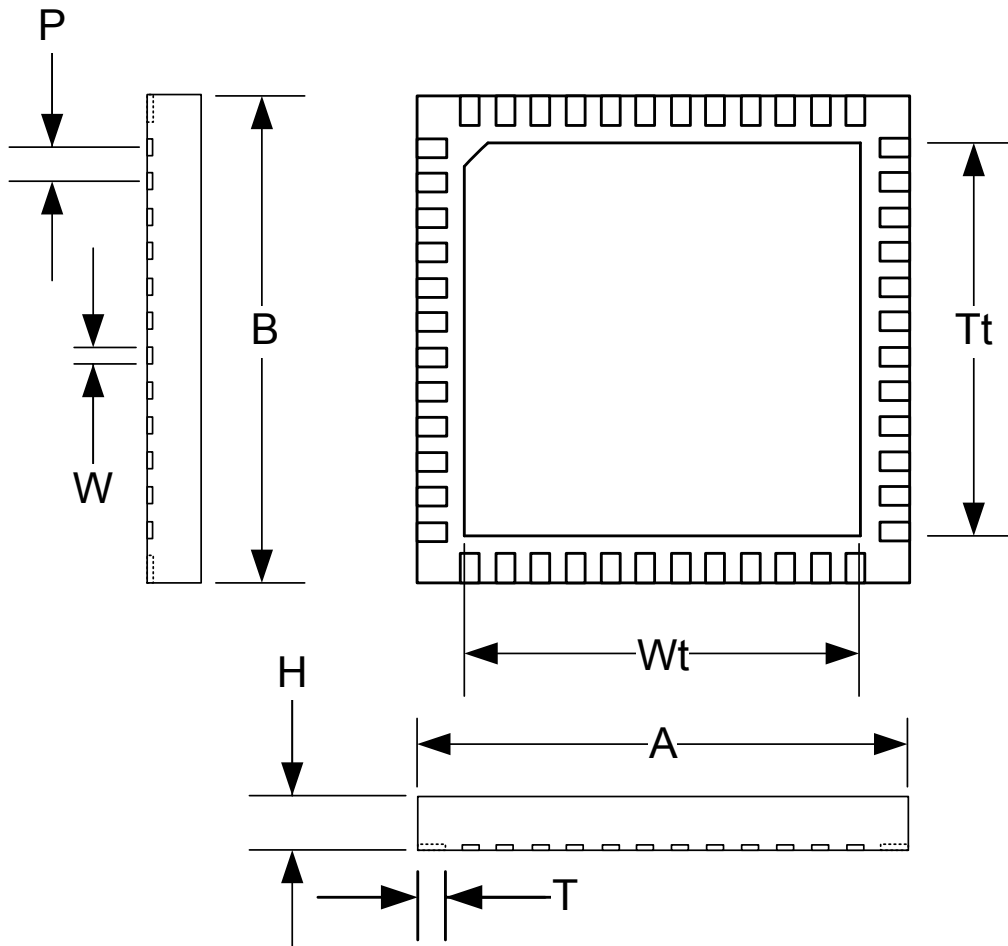

Figure 8.1 QFN(7x7)-48 Package

Table 8.1 Dimensions from Figure 8.1

Label	Dimension (mm)	Label	Dimension (mm)
P	0.50	Wt (max)	5.65
T (min)	0.30	Ft (max)	0.35
T (max)	0.50	A (min) / B (min)	6.90
W (min)	0.20	A (max) / B (max)	7.10
W (max)	0.30	H (max)	0.6
Tt (max)	5.65		



8.2 IQS550 Landing Pad Layout

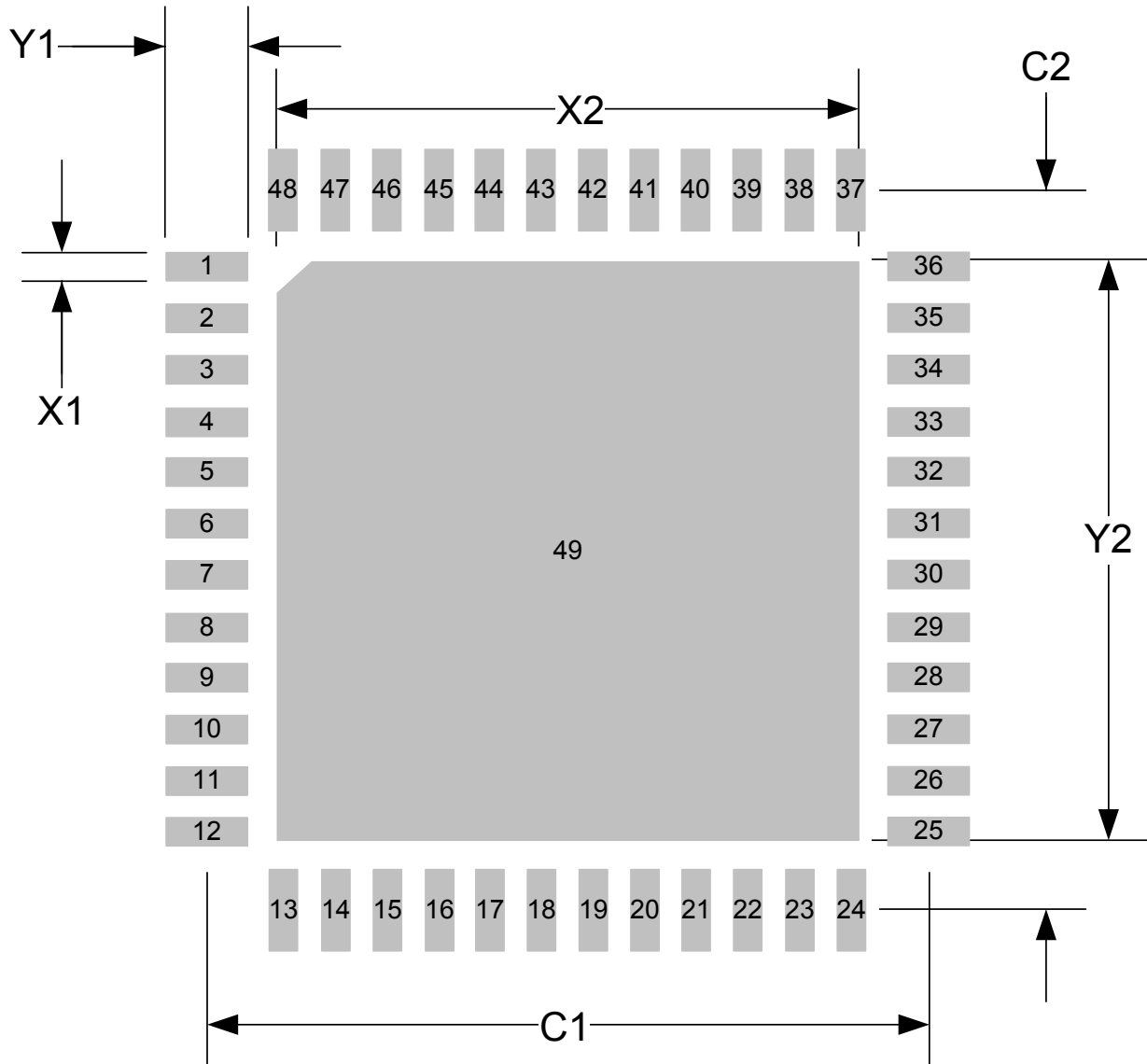

Figure 8.2 QFN(7x7)-48 Footprint

Table 8.2 Dimensions from Figure 8.2

Label	Dimension (mm)	Label	Dimension (mm)
C1	7.00	C2	7.00
Y1	0.50	Y2	5.65
X1	0.30	X2	5.65

***Note: Pin 49 = Vss**

8.3 IQS525 QFN(4x4)-28 Mechanical Dimensions

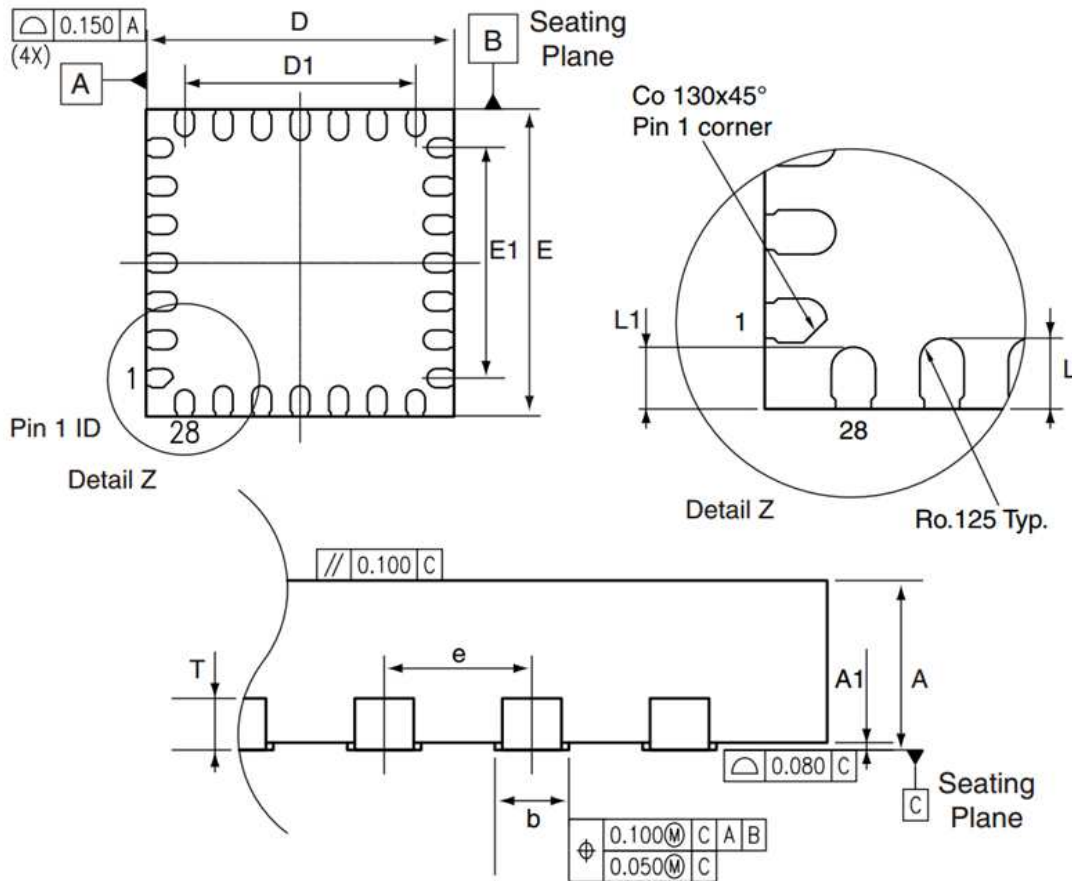

Figure 8.3 QFN(4x4)-28 Package

Table 8.3 Dimensions from Figure 8.3

Label	Dimension (mm)			Label	Dimension (mm)		
	Min	Typical	Max		Min	Typical	Max
A	0.5	0.55	0.6	L	0.3	0.4	0.5
A1	-0.05	0	0.05	L1	0.25	0.35	0.45
D	3.9	4.0	4.1	T		0.152	
D1	2.9	3.0	3.1	b	0.2	0.25	0.3
E	3.9	4.0	4.1	e		0.5	
E1	2.9	3.0	3.1				



8.5 IQS512 TSSOP20 Mechanical Dimensions

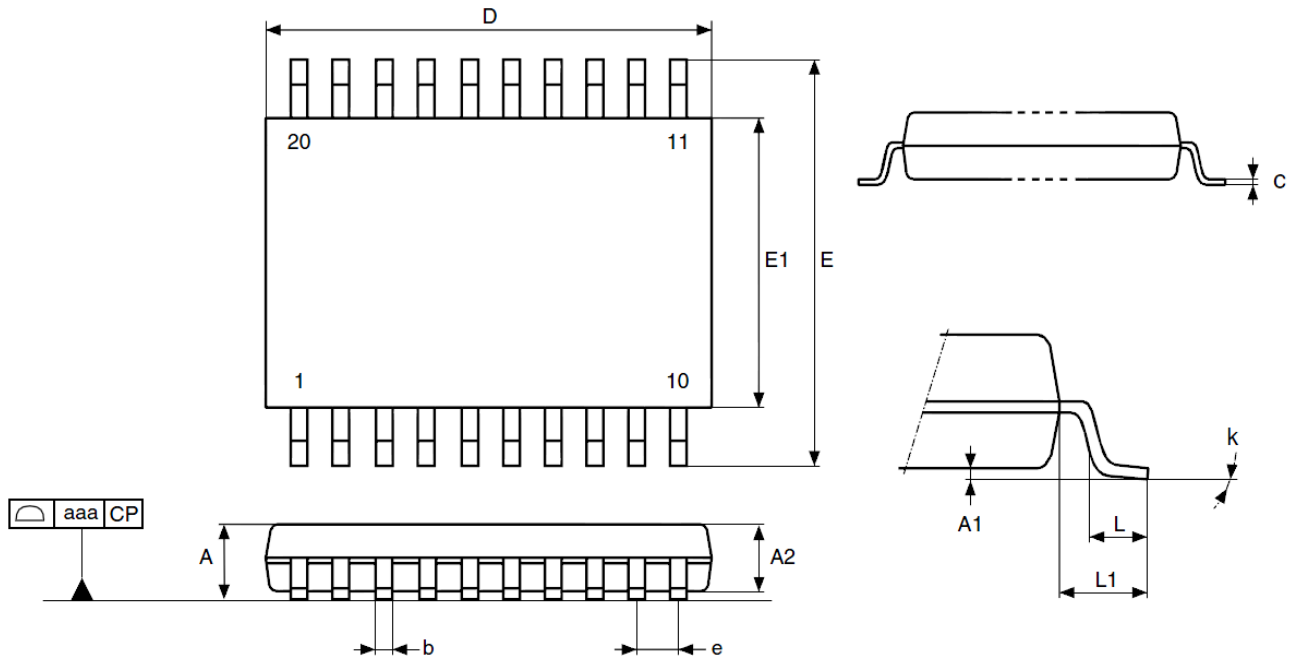

Figure 8.5 TSSOP20 Package

Table 8.4 Dimensions from Figure 8.5

Label	Dimension (mm)			Label	Dimension (mm)		
	Min	Typical	Max		Min	Typical	Max
A			1.2	E1	4.3	4.4	4.5
A1	0.05		0.15	e		0.65	
A2	0.8	1.0	1.05	L	0.45	0.60	0.75
b	0.19		0.30	L1		1.0	
c	0.09		0.20	k	0.0°		8.0°
D	6.4	6.5	6.6				
E	6.2	6.4	6.6				0.1



8.6 IQS512 Landing Pad Layout

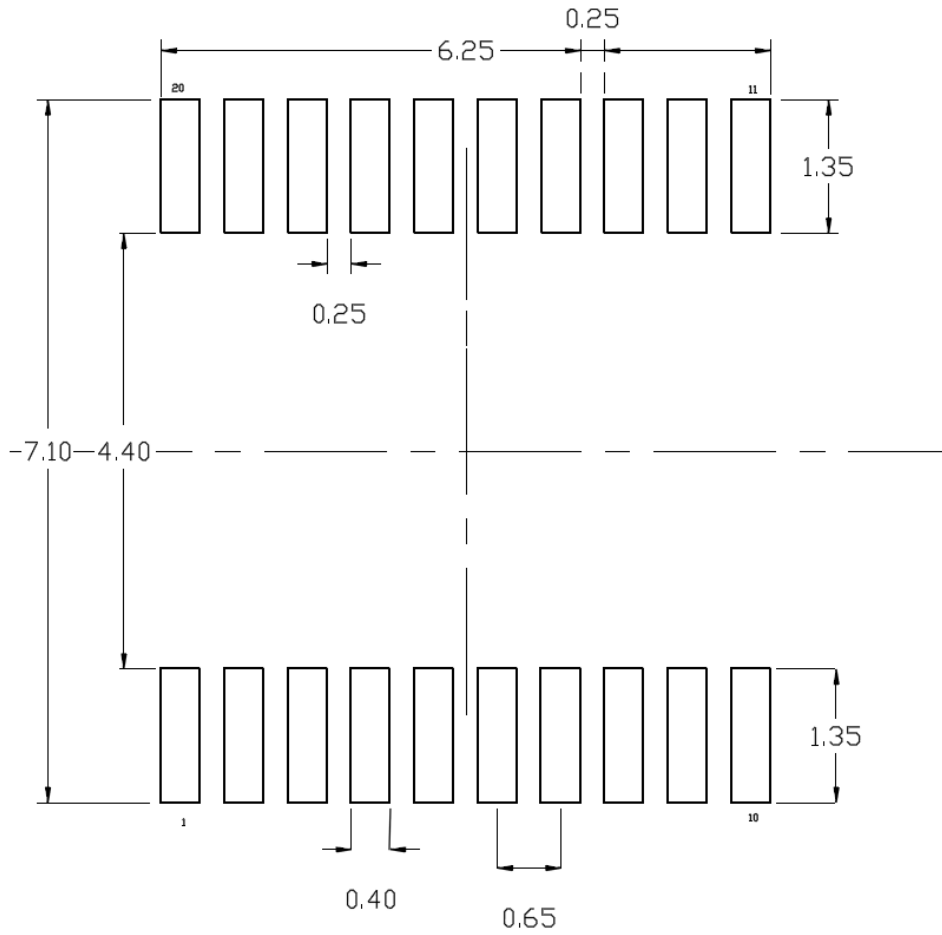
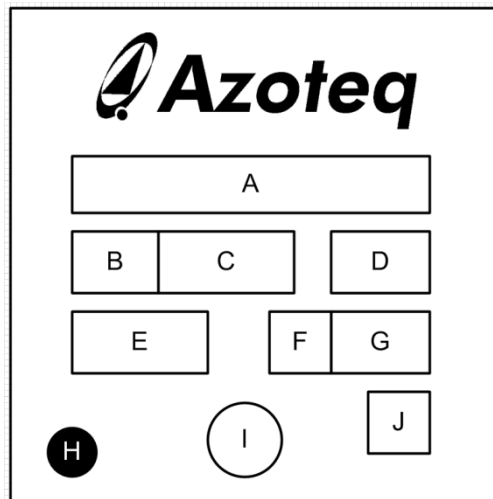

Figure 8.6 TSSOP Footprint (dimensions in millimeters)



9 Device Marking

9.1 IQS550 Marking



A	=	IC Name
B	=	Assembly Plant
C	=	<i>Internal use</i>
D	=	<i>Internal use</i>
E	=	Country of Origin
F	=	Assembly Year
G	=	Assembly Week
H	=	Dot – Pin1 reference
I	=	<i>Internal use</i>
J	=	Design Revision



9.2 IQS525 Marking

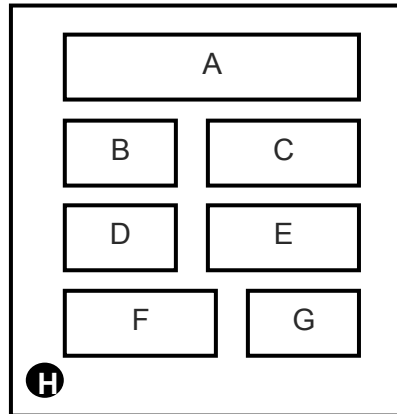

A	=	IC Name
B	=	Assembly Plant
C	=	<i>Internal use</i>
D	=	<i>Internal use</i>
E	=	Country of Origin
F	=	Assembly Date
G	=	Additional Information including Design Revision Code
H	=	Dot – Pin1 reference

9.3 IQS512 Marking

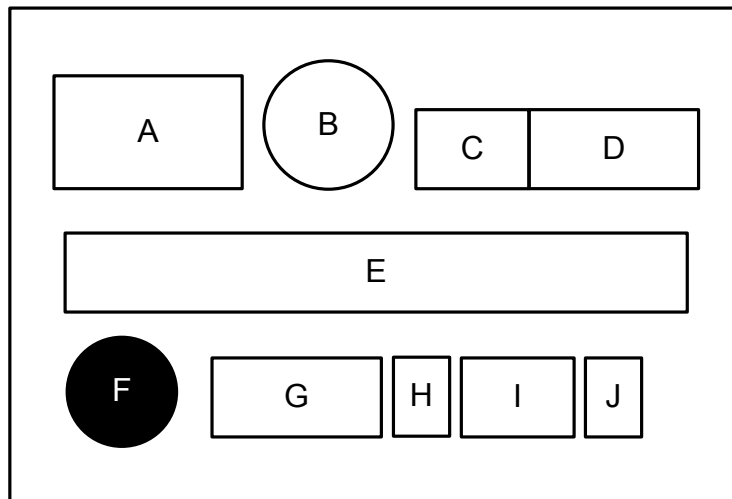

A	=	-	F	=	Dot – Pin1 reference
B	=	<i>Internal use</i>	G	=	Country of Origin
C	=	<i>Internal use</i>	H	=	Assembly Year
D	=	<i>Internal use</i>	I	=	Assembly Week
E	=	IC Name	J	=	Design Revision



10 Ordering Information

Order quantities will be subject to multiples of full reels. For large orders, Azoteq can provide custom configured devices.

10.1 IQS550 Ordering

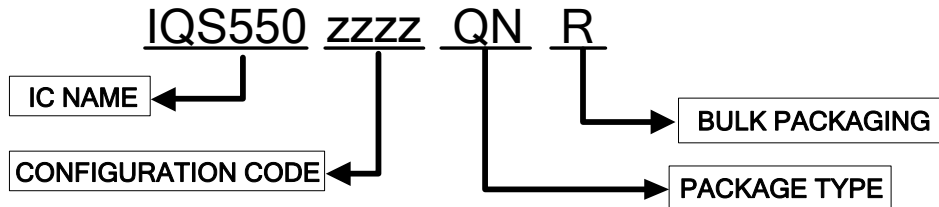

IC NAME	IQS550	=	IQS550
CONFIGURATION CODE	A000 0000	=	Preprogrammed (trackpad specific firmware) Unprogrammed
PACKAGE TYPE	QN	=	QFN(7x7)-48
BULK PACKAGING	R	=	Reel (2500pcs/reel)

10.2 IQS525 Ordering

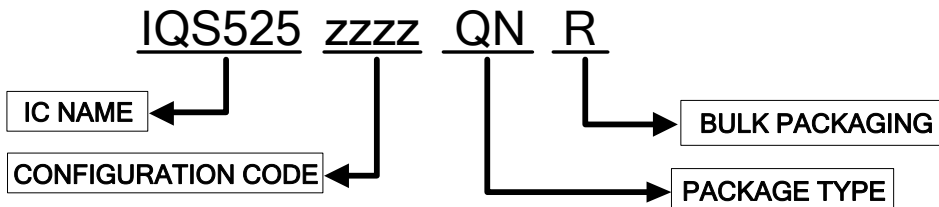

IC NAME	IQS525	=	IQS525
CONFIGURATION CODE	0000	=	Unprogrammed
PACKAGE TYPE	QN	=	QFN(4x4)-28
BULK PACKAGING	R	=	Reel (3000pcs/reel)

10.3 IQS512 Ordering

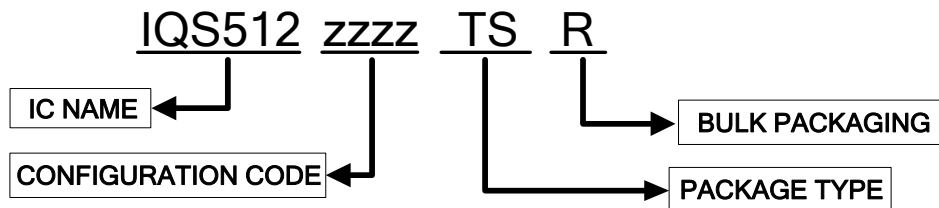

IC NAME	IQS512	=	IQS512
CONFIGURATION CODE	0000	=	Unprogrammed
PACKAGE TYPE	TS	=	TSSOP20
BULK PACKAGING	R	=	Reel (2500pcs/reel)



Changes:

Release v1.00

- IQS550 datasheet released

Release v1.01

- Removed all communication timeout information (RDY timeout)
- Add normal mode sample filtering and its relative settings
- Changed naming of Low Power sleep time to just Low-Power timing
- Added SleepTime (permanent sleep interval during every cycle)
- Removed Main Oscillator settings, system now only 16MHz, with addition of permanent Sleep to decrease current consumption.

Release v1.02 (Changes implemented to reflect firmware release 54 changes)

- Software changes not affecting this document:
 - Fixed a bit error in XY calculations (only observed with new panels with very high sensor gain)
 - Changed on-chip i2c from software to hardware implementation
 - Fixed multiple co-ordinates shown with a single touch on Rx0/Tx0 channel
 - Updated to libraries
 - Added timer updating/compensating for sleep periods.
 - Updated reseed in AutoATI routine
 - Changed XY calculations to only use positive delta's
 - Updated PM reseed to use the filtered value – if filter enabled
 - Separate reseed counters of Normal Mode and Prox Mode implemented, no longer just one global reseed counter. But they use the same setting.
- Changed the terminology 'Click' to 'Snap' (to remove confusion with mouse 'clicks' also implemented on trackpads)
- Added SYNC settings to ProxSettings0
- Support timing up till 5s (Updated Table 5.13)
- Added selectable debounce values (Added Section 3.14, Updated Table 5.1, Added Section 5.6.18)
- Updated Figure 3.2
- Added second set of settings for non-trackpad channels. ATI and threshold options added. (Update Section 3.9, Section 4.3, Section 5.6.12, Table 5.9, Section 3.11, Section 3.12)
- Added an automatic update of the Normal Mode channels when the mode is set to Auto. (since it could be possible that system stays in ProxMode for long periods of time, the LTA's of the NormalMode must be kept up to date). Updated Section 3.4.
- Added selectable 'reverse' sensing to ProxMode channel. Updated Section 3.11 and Section 5.6.10.
- Added selectable Events to trigger the EventMode operation. Updated Section 4.1 and Section 5.6.10.
- Updated Section 4.6.
- Added i2c comms timeout, Updated Section 5.6.14.
- Updated Figure 2.1 and Figure 6.1



Release v1.03

- Terminology update and minor fixes
- Changed Pretoria office address
- Updated Patent information

Release v1.04

- Changes Product and Project Number (2 bytes each). Also Split version number into a Major Revision, and Minor Revision number (1 byte each). Updated Section 5.6.1.
- Reduced NO_OF_FINGERS in XYInfoByte from 4 to 3 bits. And added a global Snap status to the available bit. Updated Section 5.6.2.
- Added I2C read rights to all the settings, so that designer can read back settings for confirmation. Updated Table 5.1.
- Added ProxMode layout suggestion to Section 3.3 (added Figure 3.1)

Release v1.05

- Updated front page
- Added NRST cap to Figure 6.1
- Added Figure 6.4 application circuit
- Updated ATI Target description in Table 5.21 and Table 5.10

Release v1.06

- Included IQS525 and IQS512 throughout datasheet:
 - Modified front page
 - Added Sections 2.2, 2.3, 8.3, 8.4, 8.5, 8.6, 9.2, 9.3, 10.2, 10.3
 - Update Table 5.14, Table 5.16, Table 7.6
 - Added circuit diagrams to Section 6
- Changed report rate Section 3.6 and added Table 7.7
- Changed pin name Vdd to Vddhi
- Updated Ordering information
- Add SingleXY output mode, update Section 5.6.10
- Add new proxmode option, summary channel (all trackpad channels together). Updated Section 5.6.15



PRETORIA OFFICE

Physical Address

Menlyn Square, East Block, First Floor

116 Lois, C/O Gobie Avenue

Menlyn

Pretoria

0181

Republic of South Africa

Tel: +27 12 361 9338

Fax: +27 12 361 3784

PAARL OFFICE

Physical Address

109 Main Street

Paarl

7646

Western Cape

Republic of South Africa

Tel: +27 21 863 0033

Fax: +27 21 863 1512

Please visit www.azoteq.com for a full portfolio of the ProxSense[®] Capacitive Sensors, Datasheets, Application Notes and Evaluation Kits available.

ProxSenseSupport@azoteq.com

The following patents relate to the device or usage of the device: US 6,249,089 B1, US 6,621,225 B2, US 6,650,066 B2, US 6,952,084 B2, US 6,984,900 B1, US 7,084,526 B2, US 7,084,531 B2, US 7,119,459 B2, US 7,265,494 B2, US 7,291,940 B2, US 7,329,970 B2, US 7,336,037 B2, US 7,443,101 B2, US 7,466,040 B2, US 7,498,749 B2, US 7,528,508 B2, US 7,755,219 B2, US 7,772,781, US 7,781,980 B2, US 7,915,765 B2, EP 1 120 018 B1, EP 1 206 168 B1, EP 1 308 913 B1, EP 1 530 178 B1, ZL 99 8 14357.X, AUS 761094

IQ Switch[®], ProxSense[®], LightSense[™], AirButton[®], SwipeSwitch[™] and the  logo are trademarks of Azoteq.

The information in this Datasheet is believed to be accurate at the time of publication. Azoteq assumes no liability arising from the use of the information or the product. The applications mentioned herein are used solely for the purpose of illustration and Azoteq makes no warranty or representation that such applications will be suitable without further modification, nor recommends the use of its products for application that may present a risk to human life due to malfunction or otherwise. Azoteq products are not authorized for use as critical components in life support devices or systems. No licenses to patents are granted, implicitly or otherwise, under any intellectual property rights. Azoteq reserves the right to alter its products without prior notification. For the most up-to-date information, please refer to www.azoteq.com.

WWW.AZOTEQ.COM

ProxSenseSupport@azoteq.com

Mouser Electronics

Authorized Distributor

Click to View Pricing, Inventory, Delivery & Lifecycle Information:

[Azoteq:](#)

[IQS512-A000 TSR](#) [IQS525-A000 QNR](#)