



**HESTORE.HU**

elektronikai alkatrész áruház

**EN:** This Datasheet is presented by the manufacturer.

Please visit our website for pricing and availability at [www.hestore.hu](http://www.hestore.hu).

(TLP504A)

**PROGRAMMABLE CONTROLLERS**

**AC / DC-INPUT MODULE**

**SOLID STATE RELAY**

The TOSHIBA TLP504A and TLP504A-2 consists of a photo-transistor optically coupled to a gallium arsenide infrared emitting diode.

The TLP504A offers two isolated channels in a eight lead plastic DIP package, while the TLP504A-2 provides four isolated channels in a sixteen plastic DIP package.

- Collector-Emitter Voltage : 55V (Min.)
- Current Transfer Ratio : 50% (Min.)  
     Rank GB : 100% (Min.)
- Isolation Voltage : 2500Vrms (Min.)
- UL Recognized : UL1577,  
     File No. E67349

**PIN CONFIGURATIONS (TOP VIEW)**

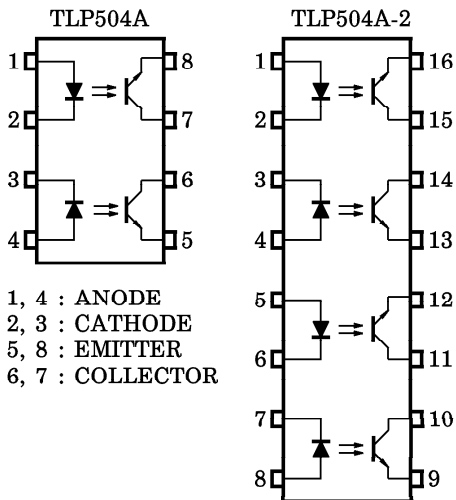

1, 4 : ANODE  
 2, 3 : CATHODE  
 5, 8 : EMITTER  
 6, 7 : COLLECTOR

1, 4, 5, 8 : ANODE  
 2, 3, 6, 7 : CATHODE  
 9, 12, 13, 16 : EMITTER  
 10, 11, 14, 15 : COLLECTOR

Unit in mm

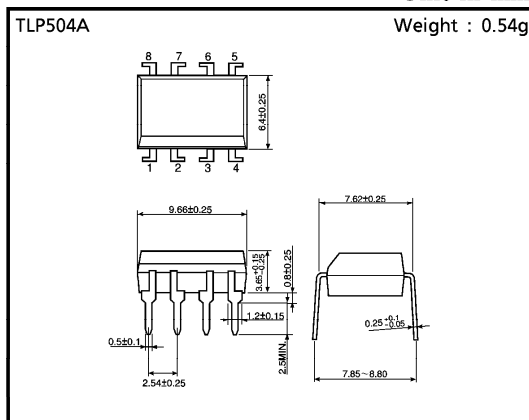

JEDEC	—
EIAJ	—
TOSHIBA	11-10C4

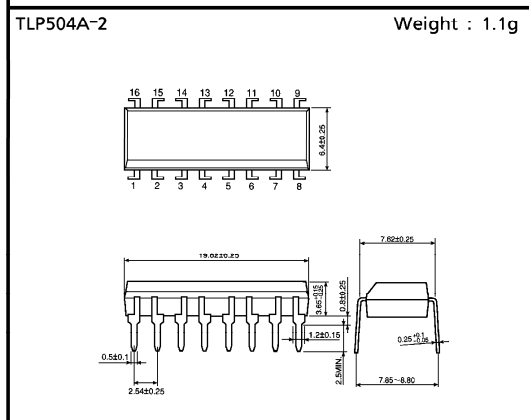

JEDEC	—
EIAJ	—
TOSHIBA	11-20A3

© The information contained herein is presented only as a guide for the applications of our products. No responsibility is assumed by TOSHIBA CORPORATION for any infringements of intellectual property or other rights of the third parties which may result from its use. No license is granted by implication or otherwise under any intellectual property or other rights of TOSHIBA CORPORATION or others.

© These TOSHIBA products are intended for use in general commercial applications (office equipment, communication equipment, measuring equipment, domestic appliances, etc.), please make sure that you consult with us before you use these TOSHIBA products in equipment which requires extraordinarily high quality and/or reliability, and in equipment which may involve life threatening or critical application, including but not limited to such uses as atomic energy control, airplane or spaceship instrumentation, traffic signals, medical instrumentation, combustion control, all types of safety devices, etc. TOSHIBA cannot accept and hereby disclaims liability for any damage which may occur in case the TOSHIBA products are used in such equipment or applications without prior consultation with TOSHIBA.



TLP504A - 1

1996 - 4 - 8

**TOSHIBA CORPORATION**

(TLP504A)

MAXIMUM RATINGS (Ta = 25°C)

CHARACTERISTIC	SYMBOL	RATING		UNIT	
		TLP504A	TLP504A-2		
LED	Forward Current	I <sub>F</sub>	60	50	mA
	Forward Current Derating	ΔI <sub>F</sub> / °C	-0.7 (Ta ≥ 39°C)	-0.5 (Ta ≥ 25°C)	mA / °C
	Pulse Forward Current	I <sub>FP</sub>	1 (100μs pulse, 100pps)		A
	Reverse Voltage	V <sub>R</sub>	5		V
	Junction Temperature	T <sub>j</sub>	125		°C
DETECTOR	Collector-Emitter Voltage	V <sub>CEO</sub>	55		V
	Emitter-Collector Voltage	V <sub>ECO</sub>	7		V
	Collector Current	I <sub>C</sub>	50		mA
	Collector Power Dissipation (1 Circuit)	P <sub>C</sub>	150	100	mW
	Collector Power Dissipation Derating (1 Circuit Ta ≥ 25°C)	ΔP <sub>C</sub> / °C	-1.5	-1.0	mW / °C
	Junction Temperature	T <sub>j</sub>	125		°C
Storage Temperature Range	T <sub>stg</sub>	-55~150		°C	
Operating Temperature Range	T <sub>opr</sub>	-55~100		°C	
Lead Soldering Temperature	T <sub>sol</sub>	260 (10s)		°C	
Total Package Power Dissipation	R <sub>T</sub>	250	150	mW	
Total Package Power Dissipation Derating (Ta ≥ 25°C)	ΔP <sub>T</sub> / °C	-2.5	-1.5	mW / °C	
Isolation Voltage	BV <sub>S</sub>	2500 (AC, 1min., R.H. ≤ 60%) (Note 1)		V <sub>rms</sub>	

Note 1 : Device considered a two terminal device : LED side pins shorted together and DETECTOR side pins shorted together.

TLP504A - 2

1996 - 4 - 8

**TOSHIBA CORPORATION**

(TLP504A)

INDIVIDUAL ELECTRICAL CHARACTERISTICS (Ta = 25°C)

CHARACTERISTIC		SYMBOL	TEST CONDITION	MIN.	TYP.	MAX.	UNIT
LED	Forward Voltage	V <sub>F</sub>	I <sub>F</sub> = 10mA	1.0	1.15	1.3	V
	Reverse Current	I <sub>R</sub>	V <sub>R</sub> = 5V	—	—	10	μA
	Capacitance	C <sub>T</sub>	V = 0, f = 1MHz	—	30	—	pF
DETECTOR	Collector-Emitter Breakdown Voltage	V (BR) CEO	I <sub>C</sub> = 0.5mA	55	—	—	V
	Emitter-Collector Breakdown Voltage	V (BR) ECO	I <sub>E</sub> = 0.1mA	7	—	—	V
	Collector Dark Current	I <sub>CEO</sub>	V <sub>CE</sub> = 24V	—	10	100	nA
			V <sub>CE</sub> = 24V, Ta = 85°C	—	2	50	μA
Capacitance Collector to Emitter	C <sub>CCE</sub>	V = 0, f = 1MHz	—	10	—	pF	

COUPLED ELECTRICAL CHARACTERISTICS (Ta = 25°C)

CHARACTERISTIC	SYMBOL	TEST CONDITION	MIN.	TYP.	MAX.	UNIT
Current Transfer Ratio	I <sub>C</sub> / I <sub>F</sub>	I <sub>F</sub> = 5mA, V <sub>CE</sub> = 5V Rank GB	50	—	600	%
			100	—	600	
Saturated CTR	I <sub>C</sub> / I <sub>F</sub> (sat)	I <sub>F</sub> = 1mA, V <sub>CE</sub> = 0.4V Rank GB	—	60	—	%
			30	—	—	
Collector-Emitter Saturation Voltage	V <sub>CE</sub> (sat)	I <sub>C</sub> = 2.4mA, I <sub>F</sub> = 8mA	—	—	0.4	V
		I <sub>C</sub> = 0.2mA, I <sub>F</sub> = 1mA Rank GB	—	0.2	—	
			—	—	0.4	

ISOLATION CHARACTERISTICS (Ta = 25°C)

CHARACTERISTIC	SYMBOL	TEST CONDITION	MIN.	TYP.	MAX.	UNIT
Capacitance Input to Output	C <sub>S</sub>	V <sub>S</sub> = 0, f = 1MHz	—	0.8	—	pF
Isolation Resistance	R <sub>S</sub>	V <sub>S</sub> = 500V	5 × 10 <sup>10</sup>	10 <sup>14</sup>	—	Ω
Isolation Voltage	BV <sub>S</sub>	AC, 1 minute	2500	—	—	V <sub>rms</sub>
		AC, 1 second, in oil	—	5000	—	
		DC, 1 minute, in oil	—	5000	—	V <sub>dc</sub>

TLP504A - 3

1996 - 4 - 8

**TOSHIBA CORPORATION**

(TLP504A)

SWITCHING CHARACTERISTICS (Ta = 25°C)

CHARACTERISTIC	SYMBOL	TEST CONDITION	MIN.	TYP.	MAX.	UNIT
Rise Time	$t_r$	$V_{CC} = 10V, I_C = 2mA$ $R_L = 100\Omega$	—	2	—	$\mu S$
Fall Time	$t_f$		—	3	—	
Turn-on Time	$t_{on}$		—	3	—	
Turn-off Time	$t_{off}$		—	3	—	
Turn-on Time	$t_{ON}$	$R_L = 1.9k\Omega$ (Fig.1) $V_{CC} = 5V, I_F = 16mA$	—	2	—	$\mu S$
Storage Time	$t_s$		—	15	—	
Turn-off Time	$t_{OFF}$		—	25	—	

Fig.1 Switching Time Test Circuit

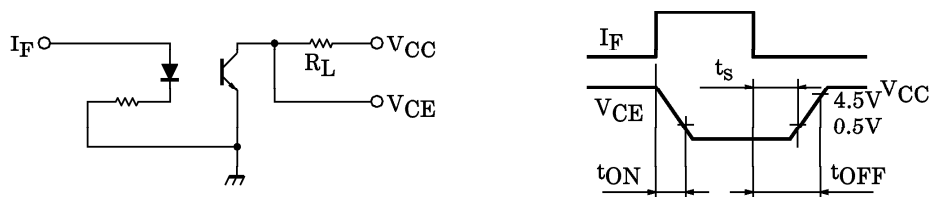

RECOMMENDED OPERATING CONDITIONS

CHARACTERISTIC	SYMBOL	MIN.	TYP.	MAX.	UNIT
Supply Voltage	$V_{CC}$	—	5	24	V
Forward Current	$I_F$	—	16	20	mA
Collector Current	$I_C$	—	1	10	mA
Operating Temperature	$T_{opr}$	-25	—	85	°C

(TLP504A)

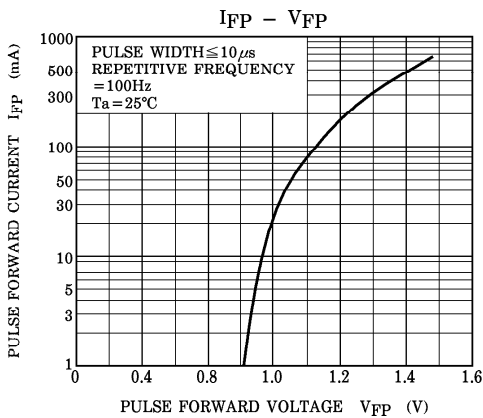
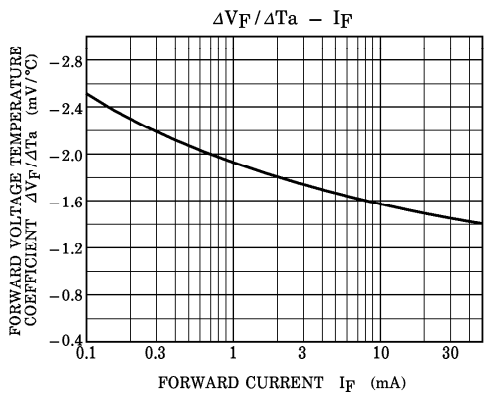
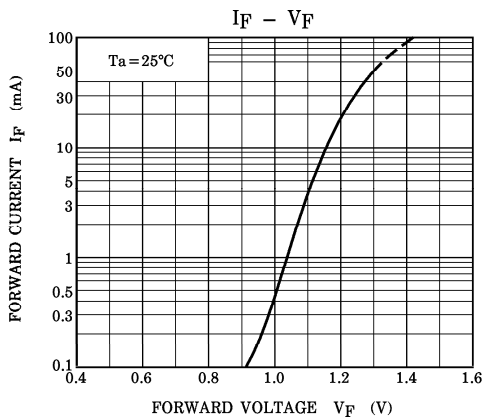
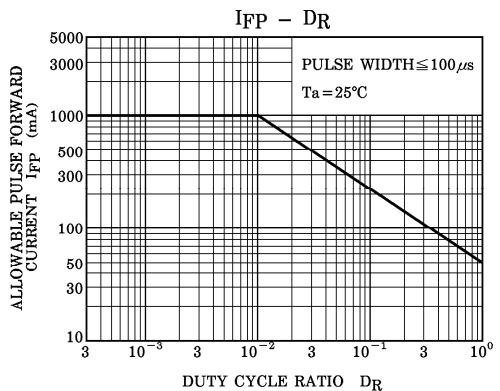
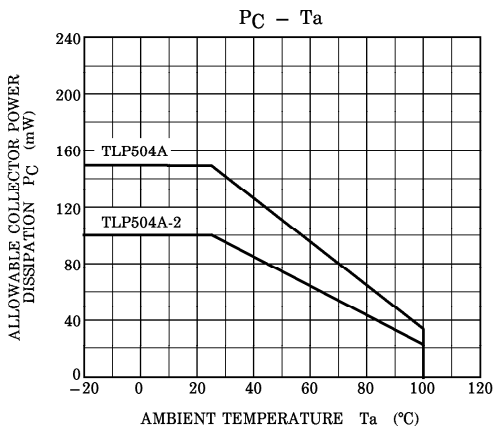
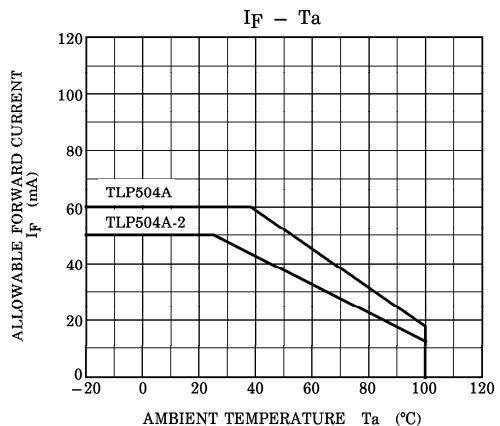

(TLP504A)

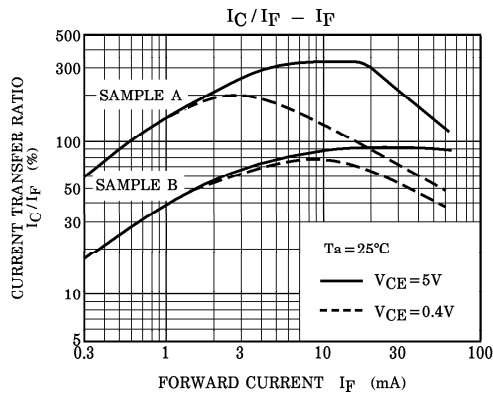
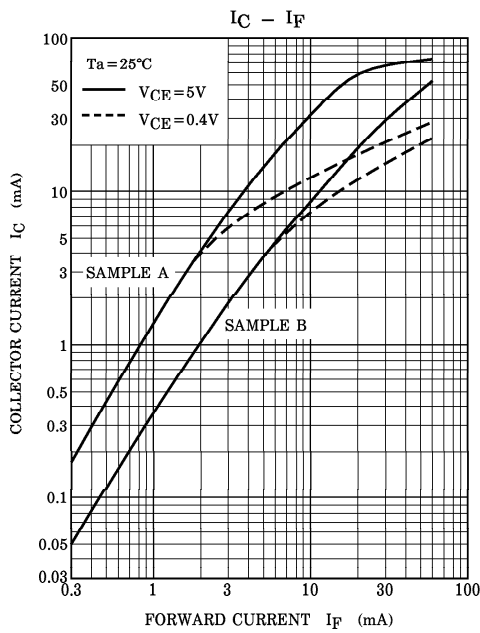
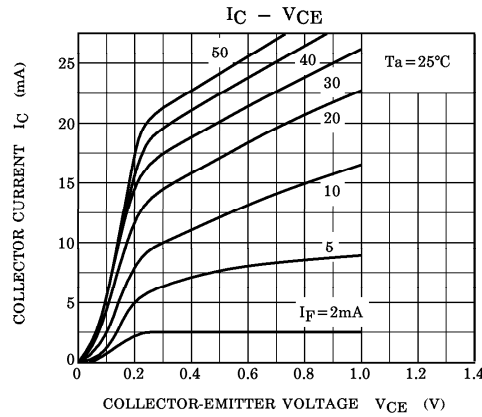
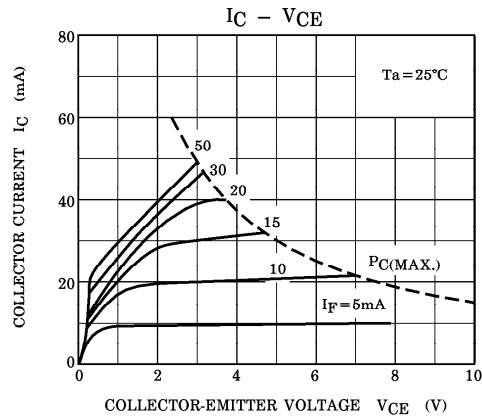
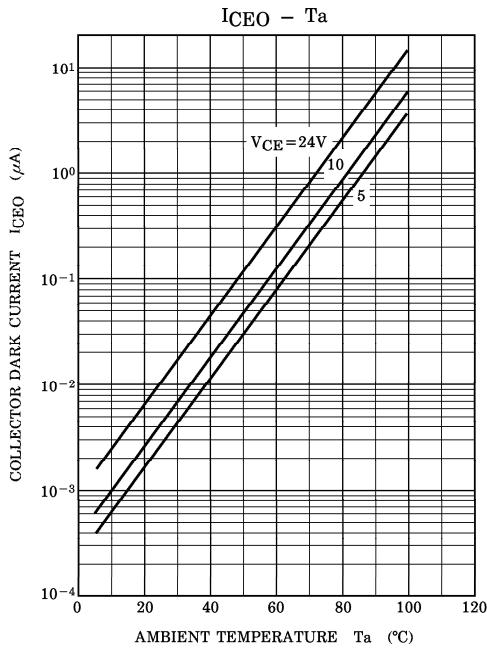

(TLP504A)

