



HESTORE.HU
elektronikai alkatrész áruház

EN: This Datasheet is presented by the manufacturer.

Please visit our website for pricing and availability at www.hestore.hu.

DATA SHEET

For a complete data sheet, please also download:

- The IC06 74HC/HCT/HCU/HCMOS Logic Family Specifications
- The IC06 74HC/HCT/HCU/HCMOS Logic Package Information
- The IC06 74HC/HCT/HCU/HCMOS Logic Package Outlines

74HC/HCT107

**Dual JK flip-flop with reset;
negative-edge trigger**

Product specification
File under Integrated Circuits, IC06

December 1990

Dual JK flip-flop with reset; negative-edge trigger

74HC/HCT107

FEATURES

- Output capability: standard
- I_{CC} category: flip-flops

GENERAL DESCRIPTION

The 74HC/HCT107 are high-speed Si-gate CMOS devices and are pin compatible with low power Schottky TTL (LSTTL). They are specified in compliance with JEDEC standard no. 7A.

The 74HC/HCT107 are dual negative-edge triggered JK-type flip-flops featuring individual J, K, clock (\overline{nCP}) and reset (\overline{nR}) inputs; also complementary Q and \overline{Q} outputs.

The J and K inputs must be stable one set-up time prior to the HIGH-to-LOW clock transition for predictable operation.

The reset (\overline{nR}) is an asynchronous active LOW input. When LOW, it overrides the clock and data inputs, forcing the Q output LOW and the \overline{Q} output HIGH.

Schmitt-trigger action in the clock input makes the circuit highly tolerant to slower clock rise and fall times.

QUICK REFERENCE DATA

GND = 0 V; T_{amb} = 25 °C; t_r = t_f = 6 ns

SYMBOL	PARAMETER	CONDITIONS	TYPICAL		UNIT
			HC	HCT	
t _{PHL} / t _{PLH}	propagation delay n \overline{CP} to nQ n \overline{CP} to n \overline{Q} n \overline{R} to nQ, n \overline{Q}	C _L = 15 pF; V _{CC} = 5 V	16	16	ns
			16	18	ns
			16	17	ns
f _{max}	maximum clock frequency		78	73	MHz
C _I	input capacitance		3.5	3.5	pF
C _{PD}	power dissipation capacitance per flip-flop	notes 1 and 2	30	30	pF

Notes

1. C_{PD} is used to determine the dynamic power dissipation (P_D in μ W):

$$P_D = C_{PD} \times V_{CC}^2 \times f_i + \sum (C_L \times V_{CC}^2 \times f_o) \text{ where:}$$

f_i = input frequency in MHz

f_o = output frequency in MHz

$\sum (C_L \times V_{CC}^2 \times f_o)$ = sum of outputs

C_L = output load capacitance in pF

V_{CC} = supply voltage in V

2. For HC the condition is V_I = GND to V_{CC}
For HCT the condition is V_I = GND to V_{CC} - 1.5 V.

ORDERING INFORMATION

See "74HC/HCT/HCU/HCMOS Logic Package Information".

Dual JK flip-flop with reset; negative-edge trigger

74HC/HCT107

PIN DESCRIPTION

PIN NO.	SYMBOL	NAME AND FUNCTION
1, 8, 4, 11	1J, 2J, 1K, 2K	synchronous inputs; flip-flops 1 and 2
2, 6	1 \bar{Q} , 2 \bar{Q}	complement flip-flop outputs
3, 5	1Q, 2Q	true flip-flop outputs
7	GND	ground (0 V)
12, 9	1 $\bar{C}P$, 2 $\bar{C}P$	clock input (HIGH-to-LOW, edge-triggered)
13, 10	1 \bar{R} , 2 \bar{R}	asynchronous reset inputs (active LOW)
14	V _{CC}	positive supply voltage

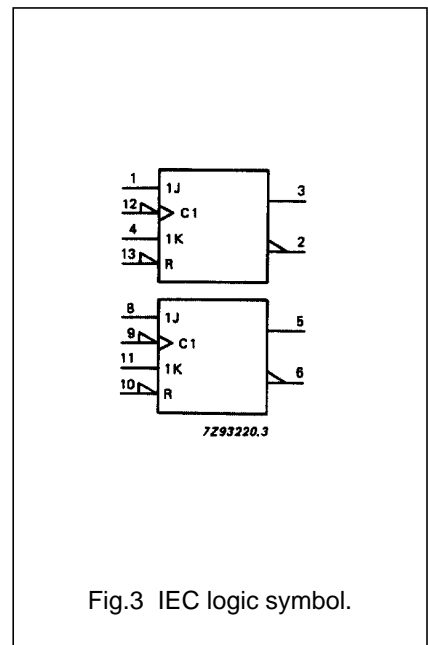
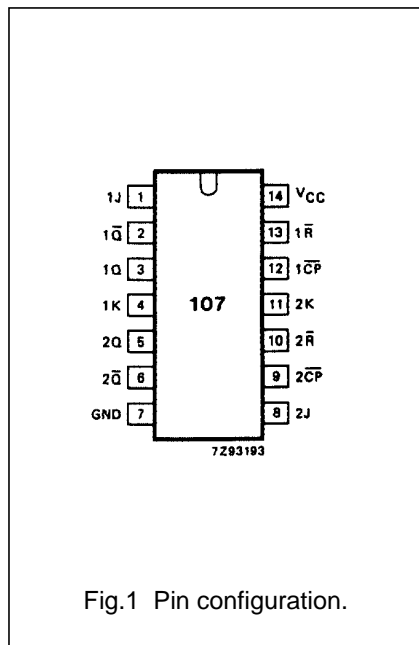

Dual JK flip-flop with reset; negative-edge trigger

74HC/HCT107

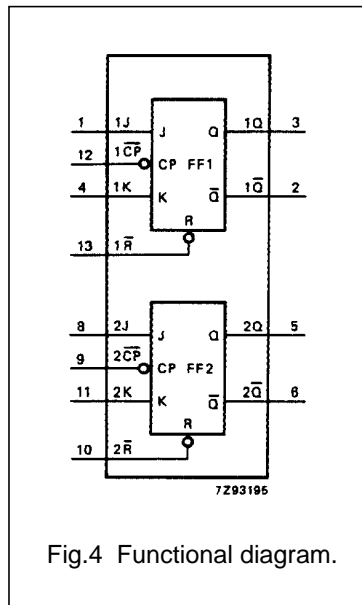

Fig.4 Functional diagram.

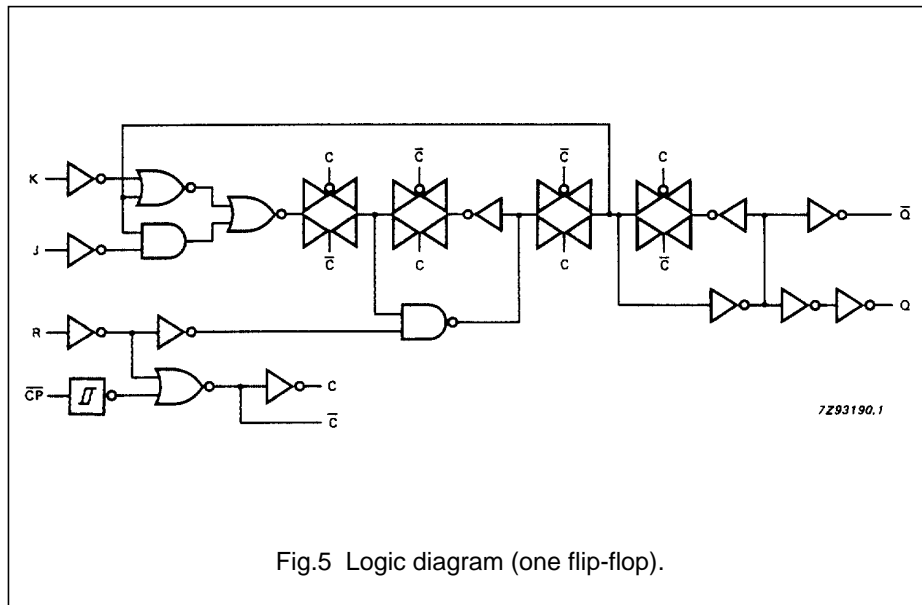

Fig.5 Logic diagram (one flip-flop).

FUNCTION TABLE

OPERATING MODE	INPUTS				OUTPUTS	
	nR-bar	nCP-bar	J	K	Q	Q-bar
asynchronous reset	L	X	X	X	L	H
toggle	H	↓	h	h	q-bar	q
load "0" (reset)	H	↓	l	h	L	H
load "1" (set)	H	↓	h	l	H	L
hold "no change"	H	↓	l	l	q	q-bar

Note

- H = HIGH voltage level
 h = HIGH voltage level one set-up time prior to the HIGH-to-LOW CP transition
 L = LOW voltage level
 l = LOW voltage level one set-up time prior to the HIGH-to-LOW CP transition
 q = lower case letters indicate the state of the referenced output one set-up time prior to the HIGH-to-LOW CP transition
 X = don't care
 ↓ = HIGH-to-LOW CP transition

Dual JK flip-flop with reset; negative-edge trigger

74HC/HCT107

DC CHARACTERISTICS FOR 74HC

For the DC characteristics see *"74HC/HCT/HCU/HCMOS Logic Family Specifications"*.

Output capability: standard

I_{CC} category: flip-flops

AC CHARACTERISTICS FOR 74HC

GND = 0 V; t_r = t_f = 6 ns; C_L = 50 pF

SYMBOL	PARAMETER	T _{amb} (°C)						UNIT	TEST CONDITIONS		
		74HC							V _{CC} (V)	WAVEFORMS	
		+25			-40 to +85		-40 to +125				
		min.	typ.	max.	min.	max.	min.				max.
t _{PHL} / t _{PLH}	propagation delay nCP to nQ		52 19 15	160 32 27		200 40 34		240 48 41	ns	2.0 4.5 6.0	Fig.6
t _{PHL} / t _{PLH}	propagation delay nCP to nQ̄		52 19 15	160 32 27		200 40 34		240 48 41	ns	2.0 4.5 6.0	Fig.6
t _{PHL} / t _{PLH}	propagation delay nR̄ to nQ, nQ̄		52 19 15	155 31 26		195 39 33		235 47 40	ns	2.0 4.5 6.0	Fig.7
t _{THL} / t _{TLH}	output transition time		19 7 6	75 15 13		95 19 16		110 22 19	ns	2.0 4.5 6.0	Fig.6
t _w	clock pulse width HIGH or LOW	80 16 14	22 8 6		100 20 17		120 24 20		ns	2.0 4.5 6.0	Fig.6
t _w	reset pulse width LOW	80 16 14	22 8 6		100 20 17		120 24 20		ns	2.0 4.5 6.0	Fig.7
t _{rem}	removal time nR̄ to nCP	60 12 10	19 7 6		75 15 13		90 18 15		ns	2.0 4.5 6.0	Fig.7
t _{su}	set-up time nJ, nK to nCP	100 20 17	22 8 6		125 25 21		150 30 26		ns	2.0 4.5 6.0	Fig.6
t _h	hold time nJ, nK to nCP	3 3 3	-6 -2 -2		3 3 3		3 3 3		ns	2.0 4.5 6.0	Fig.6
f _{max}	maximum clock pulse frequency	6.0 30 35	23 70 85		4.8 24 28		4.0 20 24		MHz	2.0 4.5 6.0	Fig.6

Dual JK flip-flop with reset; negative-edge trigger

74HC/HCT107

DC CHARACTERISTICS FOR 74HCT

For the DC characteristics see *"74HC/HCT/HCU/HCMOS Logic Family Specifications"*.

Output capability: standard

I_{CC} category: flip-flops

Note to HCT types

The value of additional quiescent supply current (ΔI_{CC}) for a unit load of 1 is given in the family specifications. To determine ΔI_{CC} per input, multiply this value by the unit load coefficient shown in the table below.

INPUT	UNIT LOAD COEFFICIENT
nK	0.60
nR	0.65
nCP, nJ	1.00

AC CHARACTERISTICS FOR 74HCT

GND = 0 V; t_r = t_f = 6 ns; C_L = 50 pF

SYMBOL	PARAMETER	T _{amb} (°C)							UNIT	TEST CONDITIONS	
		74HCT								V _{CC} (V)	WAVEFORMS
		+25			-40 to +85		-40 to +125				
		min.	typ.	max.	min.	max.	min.	max.			
t _{PHL} / t _{PLH}	propagation delay nCP to nQ		19	36		45		54	ns	4.5	Fig.6
t _{PHL} / t _{PLH}	propagation delay nCP to nQ		21	36		45		54	ns	4.5	Fig.6
t _{PHL} / t _{PLH}	propagation delay nR to nQ, nQ		20	38		48		57	ns	4.5	Fig.7
t _{THL} / t _{TLH}	output transition time		7	15		19		22	ns	4.5	Fig.6
t _w	clock pulse width HIGH or LOW	16	9		20		24		ns	4.5	Fig.6
t _w	reset pulse width LOW	20	11		25		30		ns	4.5	Fig.7
t _{rem}	removal time nR to nCP	14	8		18		21		ns	4.5	Fig.7
t _{su}	set-up time nJ, nK to nCP	20	7		25		30		ns	4.5	Fig.6
t _h	hold time nJ, nK to nCP	5	-2		5		5		ns	4.5	Fig.6
f _{max}	maximum clock pulse frequency	30	66		24		20		MHz	4.5	Fig.6

Dual JK flip-flop with reset; negative-edge trigger

74HC/HCT107

AC WAVEFORMS

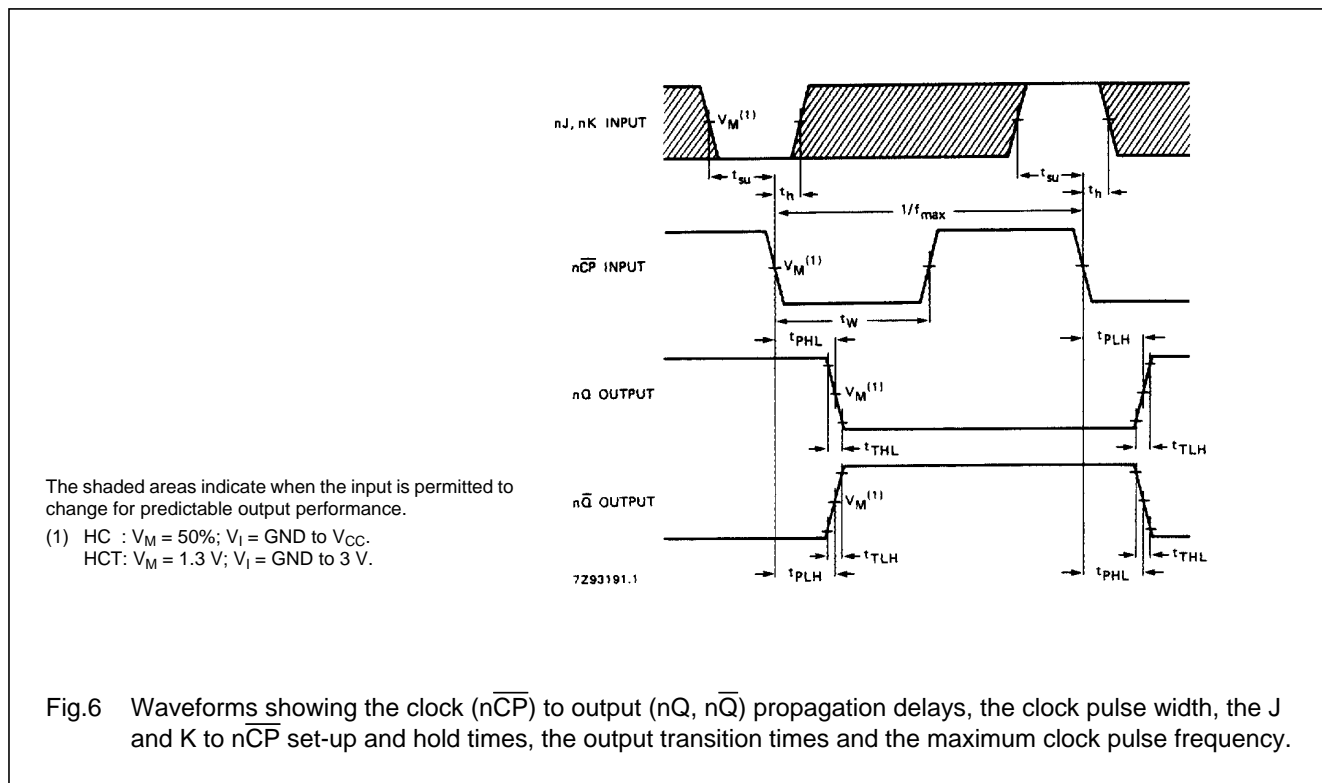

Fig.6 Waveforms showing the clock (\overline{nCP}) to output (nQ , \overline{nQ}) propagation delays, the clock pulse width, the J and K to \overline{nCP} set-up and hold times, the output transition times and the maximum clock pulse frequency.

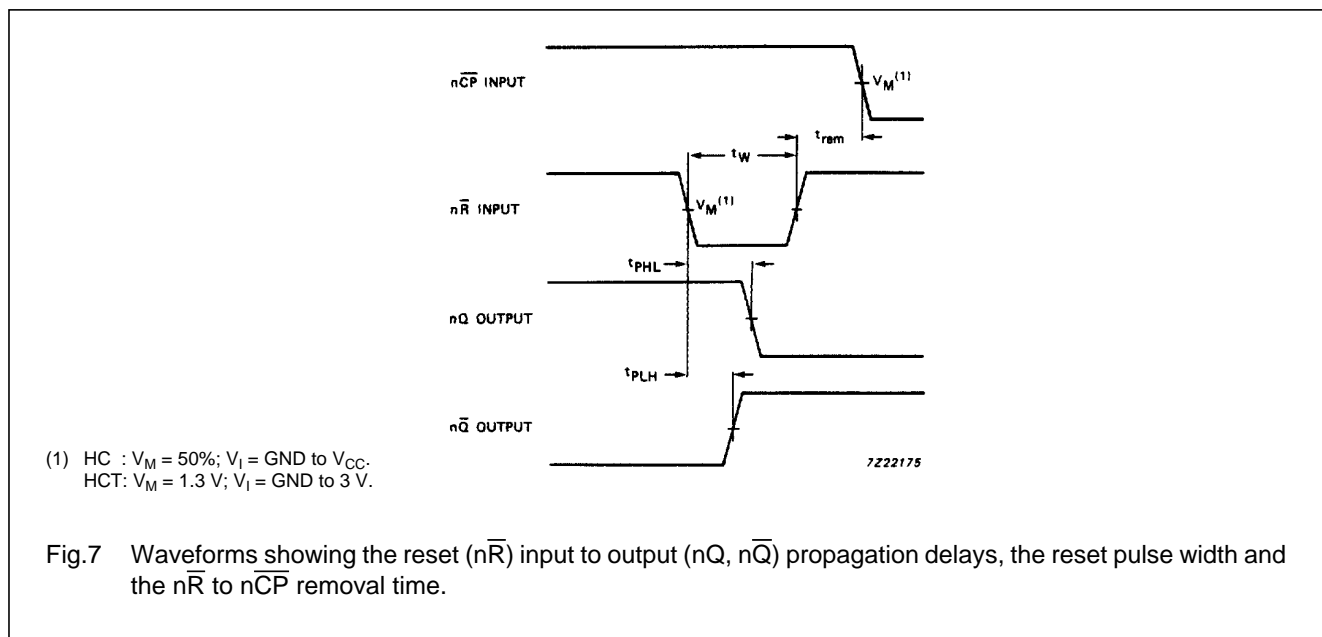

Fig.7 Waveforms showing the reset (\overline{nR}) input to output (nQ , \overline{nQ}) propagation delays, the reset pulse width and the \overline{nR} to \overline{nCP} removal time.

PACKAGE OUTLINES

See "74HC/HCT/HCU/HCMOS Logic Package Outlines".