



**HESTORE.HU**

elektronikai alkatrész áruház

**EN:** This Datasheet is presented by the manufacturer.

Please visit our website for pricing and availability at [www.hestore.hu](http://www.hestore.hu).

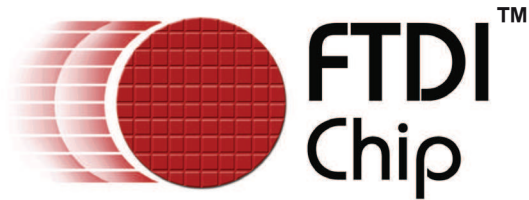

**Future Technology Devices International Ltd.**

# **MM232R Mini USB- Serial UART Development Module**

## **Incorporating Clock Generator Output and FTDIChip-ID™ Security Dongle**

*The **MM232R** is a miniature development module which uses FTDI's FT232RQ, the latest device to be added to FTDI's range of USB UART interface Integrated Circuit Devices.*

*The FT232RQ is a USB to serial UART interface with optional clock generator output, and the new FTDIChip-ID™ security dongle feature. In addition, asynchronous and synchronous bit bang interface modes are available. USB to serial interface designs using the FT232RQ have been further simplified by fully integrating the external EEPROM, clock circuit and USB resistors onto the device.*

*The FT232RQ adds two new functions compared with its predecessors, effectively making it a "3-in-1" chip for some application areas. The internally generated clock (6MHz, 12MHz, 24MHz, and 48MHz) can be brought out of the device and used to drive a microcontroller or external logic. A unique number (the FTDIChip-ID™) is burnt into the device during manufacture and is readable over USB, thus forming the basis of a security dongle which can be used to protect customer application software from being copied.*

*The MM232R is supplied on a ultra-small 18.0mm x 21.5mm (0.7" x 0.8") PCB. The module board interface is brought out on 16 PCB header pins which are on a 2.55mm (0.1") pitch. All components used, including the FT232RQ are Pb-free (RoHS compliant).*

# 1. Features

## 1.1 Hardware Features

- Single chip USB to asynchronous serial data transfer interface.
- Entire USB protocol handled on the chip - No USB-specific firmware programming required.
- UART interface support for 7 or 8 data bits, 1 or 2 stop bits and odd / even / mark / space / no parity.
- Fully assisted hardware or X-On / X-Off software handshaking.
- Data transfer rates from 300 baud to 3 Megabaud (RS422 / RS485 and at TTL levels) and 300 baud to 1 Megabaud (RS232).
- FTDI's royalty-free VCP and D2XX drivers eliminate the requirement for USB driver development in most cases.
- In-built support for event characters and line break condition.
- New USB FTDIChip-ID™ feature.
- New configurable CBUS I/O pins.
- Auto transmit buffer control for RS485 applications.
- Transmit and receive LED drive signals.
- New 48MHz, 24MHz, 12MHz, and 6MHz clock output signal Options for driving external MCU or FPGA.
- FIFO receive and transmit buffers for high data throughput.
- Adjustable receive buffer timeout.
- Synchronous and asynchronous bit bang mode interface options with RD# and WR# strobes.
- New CBUS bit bang mode option.
- Integrated 1024 bit internal EEPROM for storing USB VID, PID, serial number and product description strings, and CBUS I/O configuration.
- Device supplied preprogrammed with unique USB serial number.
- Support for USB suspend and resume.
- Support for bus powered, self powered, and high-power bus powered USB configurations.
- On board jumper allows for selection of USB bus powered supply or self powered supply.
- Integrated 3.3V level converter for USB I/O .
- Integrated level converter on UART and CBUS for interfacing to 5V - 1.8V Logic.
- On board jumper allows for selection of UART and CBUS interface IO voltage.
- True 5V / 3.3V / 2.8V / 1.8V CMOS drive output and TTL input.
- High I/O pin output drive option.
- Integrated USB resistors.
- Integrated power-on-reset circuit.
- Fully integrated clock - no external crystal, oscillator, or resonator required.
- Fully integrated AVCC supply filtering - No separate AVCC pin and no external R-C filter required.
- UART signal inversion option.
- USB bulk transfer mode.
- 3.3V to 5.25V Single Supply Operation.
- Low operating and USB suspend current.
- Low USB bandwidth consumption.
- UHCI / OHCI / EHCI host controller compatible
- USB 2.0 Full Speed compatible.
- -40°C to 85°C extended operating temperature range.
- Supplied on miniature 18.0mm x 21.5mm PCB with 16 board header pins (on 2.25mm / 0.1" pitch).
- Connect to a PC via a standard USB A to B USB cable.
- Two 1x4 and one 2x4 PCB header sockets are supplied with the MM232R module, as standard.

## 1.2 Driver Support

### Royalty-Free VIRTUAL COM PORT (VCP) DRIVERS for...

- Windows 98, 98SE, ME, 2000, Server 2003, XP.
- Windows Vista / Longhorn\*
- Windows XP 64-bit.\*
- Windows XP Embedded.
- Windows CE.NET 4.2 & 5.0
- MAC OS 8 / 9, OS-X
- Linux 2.4 and greater

### Royalty-Free D2XX Direct Drivers (USB Drivers + DLL S/W Interface)

- Windows 98, 98SE, ME, 2000, Server 2003, XP.
- Windows Vista / Longhorn\*
- Windows XP 64-bit.\*
- Windows XP Embedded.
- Windows CE.NET 4.2 & 5.0
- Linux 2.4 and greater

The drivers listed above are all available to download for free from the FTDI website. Various 3rd Party Drivers are also available for various other operating systems - see the [FTDI website](#) for details.

\* Currently Under Development. Contact FTDI for availability.

## 1.3 Typical Applications

- USB to RS232 / RS422 / RS485 Converters
- Upgrading Legacy Peripherals to USB
- Cellular and Cordless Phone USB data transfer cables and interfaces
- Interfacing MCU / PLD / FPGA based designs to USB
- USB Audio and Low Bandwidth Video data transfer
- PDA to USB data transfer
- USB Smart Card Readers
- USB Instrumentation
- USB Industrial Control
- USB MP3 Player Interface
- USB FLASH Card Reader / Writers
- Set Top Box PC - USB interface
- USB Digital Camera Interface
- USB Hardware Modems
- USB Wireless Modems
- USB Bar Code Readers
- USB Software / Hardware Encryption Dongles

## 2. Features and Enhancements

---

### 2.1 Key Features

This section summarises the key features and enhancements of the FT232RQ IC device which is used on the MM232R Module. For further details, consult the FT232R datasheet, which is available from the [FTDI website](#).

**Integrated Clock Circuit** - Previous generations of FTDI's USB UART devices required an external crystal or ceramic resonator. The clock circuit has now been integrated onto the device meaning that no crystal or ceramic resonator is required. However, if required, an external 12MHz crystal can be used as the clock source.

**Integrated EEPROM** - Previous generations of FTDI's USB UART devices required an external EEPROM if the device were to use USB Vendor ID (VID), Product ID (PID), serial number and product description strings other than the default values in the device itself. This external EEPROM has now been integrated onto the FT232R chip meaning that all designs have the option to change the product description strings. A user area of the internal EEPROM is available for storing additional data. The internal EEPROM is programmable in circuit, over USB without any additional voltage requirement.

**Preprogrammed EEPROM** - The FT232R is supplied with its internal EEPROM preprogrammed with a serial number which is unique to each individual device. This, in most cases, will remove the need to program the device EEPROM.

**Integrated USB Resistors** - Previous generations of FTDI's USB UART devices required two external series resistors on the USBDP and USBDM lines, and a 1.5 k $\Omega$  pull up resistor on USBDP. These three resistors have now been integrated onto the device.

**Integrated AVCC Filtering** - Previous generations of FTDI's USB UART devices had a separate AVCC pin - the supply to the internal PLL. This pin required an external R-C filter. The separate AVCC pin is now connected internally to VCC, and the filter has now been integrated onto the chip.

**Less External Components** - Integration of the crystal, EEPROM, USB resistors, and AVCC filter will substantially reduce the bill of materials cost for USB interface designs using the FT232R compared to its FT232BM predecessor.

**Configurable CBUS I/O Pin Options** - There are now 5 configurable Control Bus (CBUS) lines. Options are **TXDEN** - transmit enable for RS485 designs, **PWREN#** - Power control for high power, bus powered designs, **TXLED#** - for pulsing an LED upon transmission of data, **RXLED#** - for pulsing an LED upon receiving data, **TX&RXLED#** - which will pulse an LED upon transmission OR reception of data, **SLEEP#** - indicates that the device going into USB suspend mode, **CLK48 / CLK24 / CLK12 / CLK6** - 48MHz, 24MHz, 12MHz, and 6MHz clock output signal options. There is also the option to bring out bit bang mode read and write strobes (see below). The CBUS lines can be configured with any one of these output options by setting bits in the internal EEPROM. The device is supplied with the most commonly used pin definitions preprogrammed - see Section 8 for details.

**Enhanced Asynchronous Bit Bang Mode with RD# and WR# Strobes** - The FT232R supports FTDI's BM chip bit bang mode. In bit bang mode, the eight UART lines can be switched from the regular interface mode to an 8-bit general purpose I/O port. Data packets can be sent to the device and they will be sequentially sent to the interface at a rate controlled by an internal timer (equivalent to the baud rate prescaler). With the FT232R device this mode has been enhanced so that the internal RD# and WR# strobes are now brought out of the device which can be used to allow external logic to be clocked by accesses to the bit bang I/O bus. This option will be described more fully in a separate application note.

**Synchronous Bit Bang Mode** - Synchronous bit bang mode differs from asynchronous bit bang mode in that the interface pins are only read when the device is written to. Thus making it easier for the controlling program to measure the response to an output stimulus as the data returned is synchronous to the output data. The feature was previously seen in FTDI's FT2232C device. This option will be described more fully in a separate application note.

**CBUS Bit Bang Mode** - This mode allows four of the CBUS pins to be individually configured as GPIO pins, similar to Asynchronous bit bang mode. It is possible to use this mode while the UART interface is being used, thus providing up to four general purpose I/O pins which are available during normal operation. An application note describing this feature is available separately from the [FTDI website](#).

**Lower Supply Voltage** - Previous generations of the chip required 5V supply on the VCC pin. The FT232R will work with a Vcc supply in the range 3.3V - 5.25V. Bus powered designs would still take their supply from the 5V on the USB bus, but for self powered designs where only 3.3V is available and there is no 5V supply there is no longer any need for an additional external regulator.

**Integrated Level Converter on UART Interface and Control Signals** - VCCIO pin supply can be from 1.8V to 5V. Connecting the VCCIO pin to 1.8V, 2.8V, or 3.3V allows the device to directly interface to 1.8V, 2.8V or 3.3V and other logic families without the need for external level converter I.C. devices.

**5V / 3.3V / 2.8V / 1.8V Logic Interface** - The FT232R provides *true* CMOS Drive Outputs and TTL level Inputs.

**Integrated Power-On-Reset (POR) Circuit**- The device incorporates an internal POR function. A RESET# pin is available in order to allow external logic to reset the FT232R where required. However, for many applications the RESET# pin can be left unconnected, or pulled up to VCCIO.

**Lower Operating and Suspend Current** - The device operating supply current has been further reduced to 15mA, and the suspend current has been reduced to around 70µA. This allows greater margin for peripheral designs to meet the USB suspend current limit of 500µA.

**Low USB Bandwidth Consumption** - The operation of the USB interface to the FT232R has been designed to use as little as possible of the total USB bandwidth available from the USB host controller.

**High Output Drive Option** - The UART interface and CBUS I/O pins can be made to drive out at three times the standard signal drive level thus allowing multiple devices to be driven, or devices that require a greater signal drive strength to be interfaced to the FT232R. This option is enabled in the internal EEPROM.

**Power Management Control for USB Bus Powered, High Current Designs**- The PWREN# signal can be used to directly drive a transistor or P-Channel MOSFET in applications where power switching of external circuitry is required. An option in the internal EEPROM makes the device gently pull down on its UART interface lines when the power is shut off (PWREN# is high). In this mode any residual voltage on external circuitry is bled to GND when power is removed, thus ensuring that external circuitry controlled by PWREN# resets reliably when power is restored.

**UART Pin Signal Inversion** - The sense of each of the eight UART signals can be individually inverted by setting options in the internal EEPROM. Thus, CTS# (active low) can be changed to CTS (active high), or TXD can be changed to TXD#.

**FTDChip-ID™** - Each FT232R is assigned a unique number which is burnt into the device at manufacture. This ID number cannot be reprogrammed by product manufacturers or end-users. This allows the possibility of using FT232R based dongles for software licensing. Further to this, a renewable license scheme can be implemented based on the FTDChip-ID™ number when encrypted with other information. This encrypted number can be stored in the user area of the FT232R internal EEPROM, and can be decrypted, then compared with the protected FTDChip-ID™ to verify that a license is valid. Web based applications can be used to maintain product licensing this way. An application note describing this feature is available separately from the [FTDI website](#).

**Improved EMI Performance** - The reduced operating current and improved on-chip VCC decoupling significantly improves the ease of PCB design requirements in order to meet FCC, CE and other EMI related specifications.

**Programmable Receive Buffer Timeout** - The receive buffer timeout is used to flush remaining data from the receive buffer. This time defaults to 16ms, but is programmable over USB in 1ms increments from 1ms to 255ms, thus allowing the device to be optimised for protocols that require fast response times from short data packets.

**Baud Rates** - The FT232R supports all standard baud rates and non-standard baud rates from 300 Baud up to 3 Megabaud. Achievable non-standard baud rates are calculated as follows -

$$\text{Baud Rate} = 3000000 / (n + x)$$

where n can be any integer between 2 and 16,384 ( = 2<sup>14</sup> ) and x can be a sub-integer of the value 0, 0.125, 0.25, 0.375, 0.5, 0.625, 0.75, or 0.875. When n = 1, x = 0, i.e. baud rate divisors with values between 1 and 2 are not possible.

This gives achievable baud rates in the range 183.1 baud to 3,000,000 baud. When a non-standard baud rate is required simply pass the required baud rate value to the driver as normal, and the FTDI driver will calculate the required divisor, and set the baud rate. See FTDI application note AN232B-05 for more details.



**Extended Operating Temperature Range** - The FT232R operates over an extended temperature range of  $-40^{\circ}$  to  $+85^{\circ}$  C thus allowing the device to be used in automotive and industrial applications.

**New Package Options** - The FT232R is available in two packages - a compact 28 pin SSOP ( FT232RL) and an ultra-compact 5mm x 5mm pinless QFN-32 package ( FT232RQ). Both packages are lead ( Pb ) free, and use a 'green' compound. Both packages are fully compliant with European Union directive 2002/95/EC. The MM232R module uses a FT232RQ device in its design.

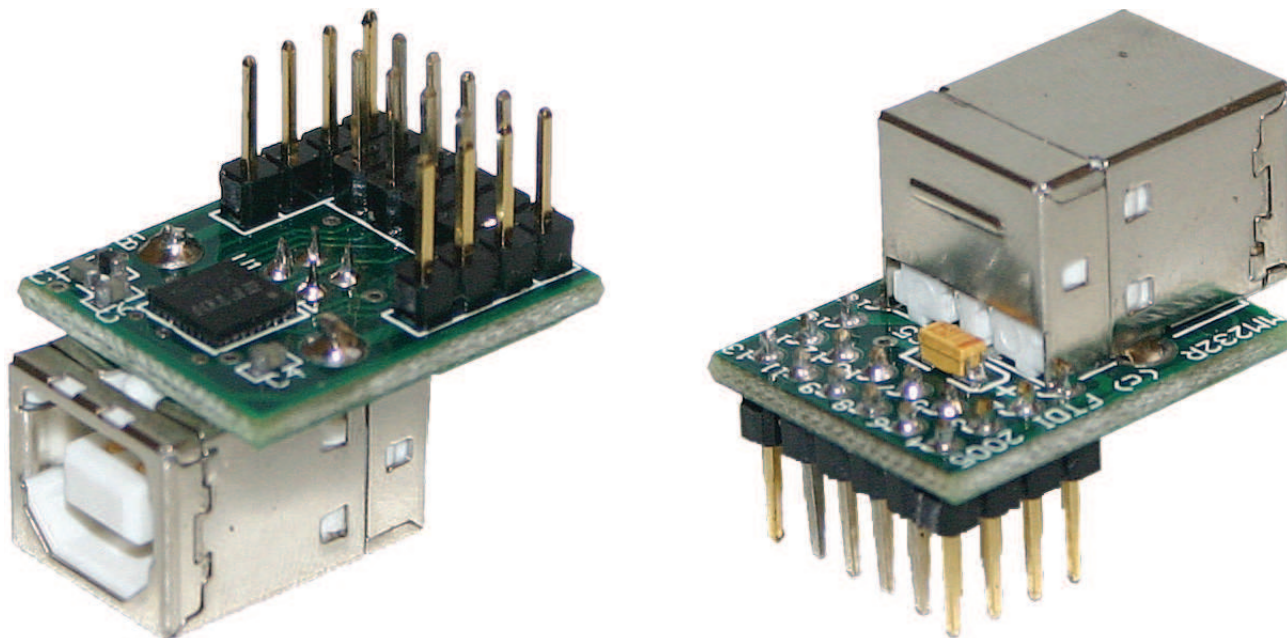

Figure 1 - The MM232R Mini Development Module.

### 3. MM232R Pin Out and Signal Descriptions

#### 3.1 MM232R Pin Out

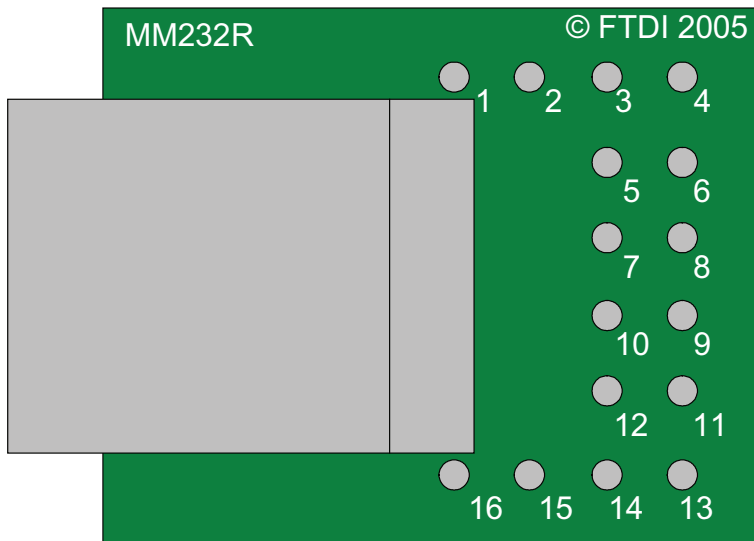

Figure 2 - Module Pin Out.

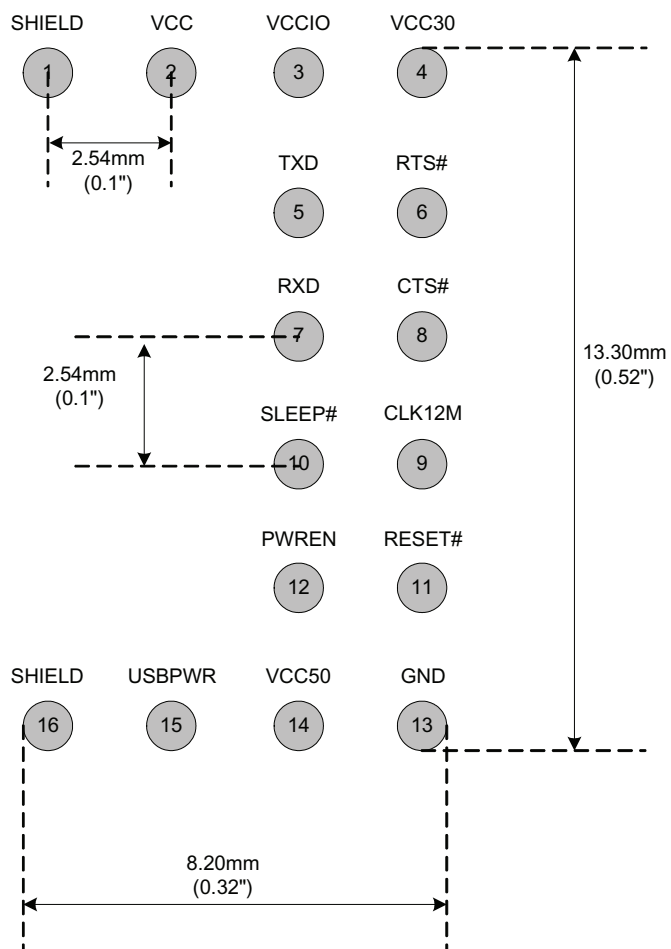

Figure 3 - MM232R Signal pin out and PCB pad layout.

## 3.2 Signal Descriptions

Table 1 - Module Pin Out Description

Pin No.	Name	Type	Description
1	SHEILD	GND	USB Cable shield.
2	VCC	PWR or Input	To power the module from the 5V supply on USB bus connect pins 15 (USBPWR) and 14 (VCC50) together. In this case this pin becomes a 5V output, and can be used to supply the VCCIO pin, or to supply external logic. To use the MM232R module in a self powered configuration supply an external 3V - 5V supply to this pin, and do not connect together pins 15 and 14.
3	VCCIO		+1.8V to +5.25V supply to the FT232RQ's UART Interface and CBUS I/O pins. In USB bus powered designs connect to 3V3 to drive out at 3.3V levels (connect VCCIO to VCC3O), or connect to VCC to drive out at 5V CMOS level (connect VCCIO to VCC). This pin can also be supplied with an external 1.8V - 2.8V supply in order to drive out at lower levels. It should be noted that in this case this supply should originate from the same source as the supply to Vcc. This means that in bus powered designs a regulator which is supplied by the 5V on the USB bus should be used.
4	VCC3O	Output	3.3V output from integrated L.D.O. regulator. This pin is decoupled to ground on the module pcb with a 100nF capacitor. The prime purpose of this pin is to provide the internal 3.3V supply to the USB transceiver cell and the internal 1.5kΩ pull up resistor on USBDP. Up to 50mA can be drawn from this pin to power external logic if required. This pin can also be used to supply the FT232RQ's VCCIO pin by connecting this pin to pin 3 (VCCIO).
5	TXD	Output	Transmit Asynchronous Data Output.*
6	RTS#	Output	Request To Send Control Output / Handshake signal.*
7	RXD	Input	Receive Asynchronous Data Input.*
8	CTS#	Input	Clear to Send Control input / Handshake signal.*
9	CLK12	Output	Configurable CBUS I/O Pin. Function of this pin is configured in the device internal EEPROM. Factory default pin function for the MM232R module is 12MHz Clock output. See CBUS Signal Options, <a href="#">Table 2</a> .*
10	SLEEP#	Output	Configurable CBUS I/O Pin. Function of this pin is configured in the device internal EEPROM. Factory default pin function for the MM232R module is SLEEP# - Goes low during USB suspend mode. Typically used to power down an external TTL to RS232 level converter I.C. in USB to RS232 converter designs. This pin is the FT232R's CBUS4 See CBUS Signal Options, <a href="#">Table 2</a> .*
11	RESET#	Input	Can be used by an external device to reset the FT232R. If not required can be left unconnected, or pulled up to VCCIO.
12	PWREN#	Output	Configurable CBUS I/O Pin. Function of this pin is configured in the device internal EEPROM. Factory default pin function for the MM232R module is PWREN# - Goes low after the device is configured by USB, then high during USB suspend. Can be used to control power to external logic P-Channel logic level MOSFET switch. Enable the interface pull-down option when using the PWREN# pin in this way. See CBUS Signal Options, <a href="#">Table 2</a> .*
13	GND	GND	Module ground supply pins
14	VCC50	PWR	Module 3.3V - 5.25V power supply input. To power the module from the 5V supply on USB bus connect pins 15 (USBPWR) and 14 (VCC50) together.
15	USBPWR	Output	5V Power output USB port. For a low power USB bus powered design, up to 100mA can be sourced from the 5V supply on the USB bus. A maximum of 500mA can be sourced from the USB bus in a high power USB bus powered design. Connect to Pin 14 (VCC50) to power the MM232R module from the USB bus.
16	SHEILD	GND	USB Cable shield.

\* When used in Input Mode, these pins are pulled to VCCIO via internal 200kΩ resistors. These pins can be programmed to gently pull low during USB suspend ( PWREN# = "1" ) by setting an option in the internal EEPROM.



### 3.3 CBUS Signal Options

The following options can be configured on the CBUS I/O pins. These options are all configured in the internal EEPROM using the utility software MPROG, which can be downloaded from the [FTDI website](#). The default configuration is described in Section 8.

Table 2 - CBUS Signal Options

<b>CBUS Signal Option</b>	<b>Available On CBUS Pin...</b>	<b>Description</b>
TXDEN	CBUS0, CBUS1, CBUS2, CBUS3, CBUS4	Enable transmit data for RS485
TXLED#	CBUS0, CBUS1, CBUS2, CBUS3, CBUS4	Transmit data LED drive - pulses low when transmitting data via USB. See FT232R datasheet for more details.
RXLED#	CBUS0, CBUS1, CBUS2, CBUS3, CBUS4	Receive data LED drive - pulses low when receiving data via USB. See FT232R datasheet for more details.
TX&RXLED#	CBUS0, CBUS1, CBUS2, CBUS3, CBUS4	LED drive - pulses low when transmitting or receiving data via USB. See FT232R datasheet for more details.
PWREN#	CBUS0, CBUS1, CBUS2, CBUS3, CBUS4	Goes low after the device is configured by USB, then high during USB suspend. Can be used to control power to external logic P-Channel logic level MOSFET switch. Enable the interface pull-down option when using the PWREN# pin in this way.
SLEEP#	CBUS0, CBUS1, CBUS2, CBUS3, CBUS4	Goes low during USB suspend mode. Typically used to power down an external TTL to RS232 level converter I.C. in USB to RS232 converter designs.
CLK48	CBUS0, CBUS1, CBUS2, CBUS3, CBUS4	48MHz Clock output.
CLK24	CBUS0, CBUS1, CBUS2, CBUS3, CBUS4	24MHz Clock output.
CLK12	CBUS0, CBUS1, CBUS2, CBUS3, CBUS4	12MHz Clock output.
CLK6	CBUS0, CBUS1, CBUS2, CBUS3, CBUS4	6MHz Clock output.
CBitBangI/O	CBUS0, CBUS1, CBUS2, CBUS3	CBUS bit bang mode option. Allows up to 4 of the CBUS pins to be used as general purpose I/O. Configured individually for CBUS0, CBUS1, CBUS2 and CBUS3 in the internal EEPROM. A separate application note will describe in more detail how to use CBUS bit bang mode.
BitBangWRn	CBUS0, CBUS1, CBUS2, CBUS3	Synchronous and asynchronous bit bang mode WR# strobe Output
BitBangRDn	CBUS0, CBUS1, CBUS2, CBUS3	Synchronous and asynchronous bit bang mode RD# strobe Output

## 4. Module Dimensions

Figure 4 - MM232R Module Dimensions

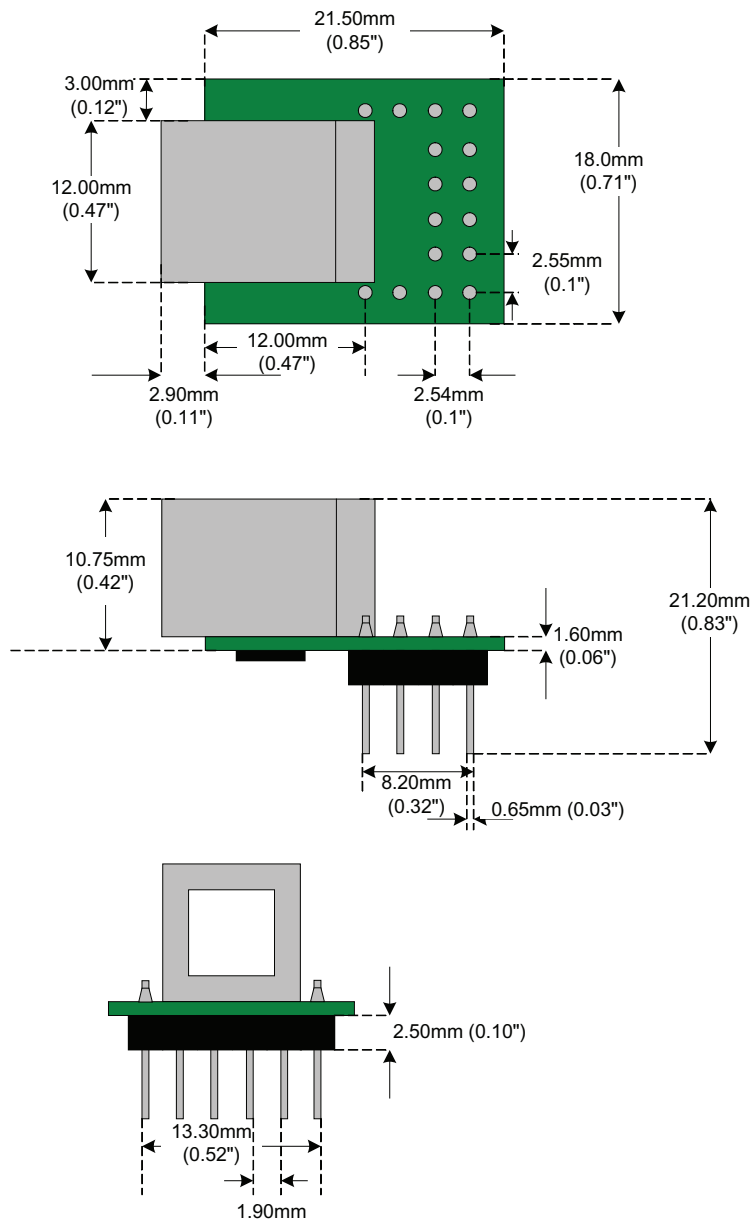

The FT232RQ is supplied in a RoHS compliant 5mm x 5mm QFN 32 package. The package is lead (Pb) free and uses a 'green' compound. The date code format is YYXX where XX = 2 digit week number, YY = 2 digit year number.

The MM232R module uses exclusively lead free components.

Both the I.C. device and the module are fully compliant with European Union directive 2002/95/EC.

## 5. Device Characteristics and Ratings

### 5.1 Absolute Maximum Ratings

The absolute maximum ratings for the FT232R devices are as follows. These are in accordance with the Absolute Maximum Rating System (IEC 60134). Exceeding these may cause permanent damage to the device.

Table 3 - Absolute Maximum Ratings

Parameter	Value	Unit
Storage Temperature	-65°C to 150°C	Degrees C
Floor Life (Out of Bag) At Factory Ambient ( 30°C / 60% Relative Humidity)	168 Hours (IPC/JEDEC J-STD-033A MSL Level 3 Compliant)*	Hours
Ambient Temperature (Power Applied)	-40°C to 85°C	Degrees C.
Vcc Supply Voltage	-0.5 to +6.00	V
D.C. Input Voltage - USBDP and USBDM	-0.5 to +3.8	V
D.C. Input Voltage - High Impedance Bidirectionals	-0.5 to +(Vcc +0.5)	V
D.C. Input Voltage - All other Inputs	-0.5 to +(Vcc +0.5)	V
D.C. Output Current - Outputs	24	mA
DC Output Current - Low Impedance Bidirectionals	24	mA
Power Dissipation (Vcc = 5.25V)	500	mW

\* If devices are stored out of the packaging beyond this time limit the devices should be baked before use. The devices should be ramped up to a temperature of 125°C and baked for up to 17 hours.

### 5.2 DC Characteristics

DC Characteristics ( Ambient Temperature = -40 to 85°C )

Table 4 - Operating Voltage and Current

Parameter	Description	Min	Typ	Max	Units	Conditions
Vcc1	VCC Operating Supply Voltage	3.3	-	5.25	V	
Vcc2	VCCIO Operating Supply Voltage	1.8	-	5.25	V	
Icc1	Operating Supply Current	-	15	-	mA	Normal Operation
Icc2	Operating Supply Current	50	70	100	µA	USB Suspend*

Table 5 - UART and CBUS I/O Pin Characteristics (VCCIO = 5.0V, Standard Drive Level)

Parameter	Description	Min	Typ	Max	Units	Conditions
Voh	Output Voltage High	3.2	4.1	4.9	V	I source = 2mA
Vol	Output Voltage Low	0.3	0.4	0.6	V	I sink = 2mA
Vin	Input Switching Threshold	1.3	1.6	1.9	V	**
VHys	Input Switching Hysteresis	50	55	60	mV	**

Table 6 - UART and CBUS I/O Pin Characteristics (VCCIO = 3.3V, Standard Drive Level)

Parameter	Description	Min	Typ	Max	Units	Conditions
Voh	Output Voltage High	2.2	2.7	3.2	V	I source = 1mA
Vol	Output Voltage Low	0.3	0.4	0.5	V	I sink = 2mA
Vin	Input Switching Threshold	1.0	1.2	1.5	V	**
VHys	Input Switching Hysteresis	20	25	30	mV	**

Table 7 - UART and CBUS I/O Pin Characteristics (VCCIO = 2.8V, Standard Drive Level)

Parameter	Description	Min	Typ	Max	Units	Conditions
Voh	Output Voltage High	2.1	2.6	3.1	V	I source = 1mA
Vol	Output Voltage Low	0.3	0.4	0.5	V	I sink = 2mA
Vin	Input Switching Threshold	1.0	1.2	1.5	V	**
VHys	Input Switching Hysteresis	20	25	30	mV	**

Table 8 - UART and CBUS I/O Pin Characteristics (VCCIO = 5.0V, High Drive Level)

Parameter	Description	Min	Typ	Max	Units	Conditions
Voh	Output Voltage High	3.2	4.1	4.9	V	I source = 6mA
Vol	Output Voltage Low	0.3	0.4	0.6	V	I sink = 6mA
Vin	Input Switching Threshold	1.3	1.6	1.9	V	**
VHys	Input Switching Hysteresis	50	55	60	mV	**

Table 9 - UART and CBUS I/O Pin Characteristics (VCCIO = 3.3V, High Drive Level)

Parameter	Description	Min	Typ	Max	Units	Conditions
Voh	Output Voltage High	2.2	2.8	3.2	V	I source = 3mA
Vol	Output Voltage Low	0.3	0.4	0.6	V	I sink = 8mA
Vin	Input Switching Threshold	1.0	1.2	1.5	V	**
VHys	Input Switching Hysteresis	20	25	30	mV	**

Table 10 - UART and CBUS I/O Pin Characteristics (VCCIO = 2.8V, High Drive Level)

Parameter	Description	Min	Typ	Max	Units	Conditions
Voh	Output Voltage High	2.1	2.8	3.2	V	I source = 3mA
Vol	Output Voltage Low	0.3	0.4	0.6	V	I sink = 8mA
Vin	Input Switching Threshold	1.0	1.2	1.5	V	**
VHys	Input Switching Hysteresis	20	25	30	mV	**

\*\*Inputs have an internal 200kΩ pull-up resistor to VCCIO.

Table 11 - RESET# and TEST Pin Characteristics

Parameter	Description	Min	Typ	Max	Units	Conditions
Vin	Input Switching Threshold	1.3	1.6	1.9	V	
VHys	Input Switching Hysteresis	50	55	60	mV	

Table 12 - USB I/O Pin (USBDP, USBDM) Characteristics

Parameter	Description	Min	Typ	Max	Units	Conditions
UVoh	I/O Pins Static Output ( High)	2.8		3.6	V	RI = 1.5kΩ to 3V3Out ( D+ ) RI = 15kΩ to GND ( D- )
UVol	I/O Pins Static Output ( Low )	0		0.3	V	RI = 1.5kΩ to 3V3Out ( D+ ) RI = 15kΩ to GND ( D- )
UVse	Single Ended Rx Threshold	0.8		2.0	V	
UCom	Differential Common Mode	0.8		2.5	V	
UVDif	Differential Input Sensitivity	0.2			V	
UDrvZ	Driver Output Impedance	26	29	44	Ohms	***

\*\*\*Driver Output Impedance includes the internal USB series resistors on USBDP and USBDM pins.

### 5.3 EEPROM Reliability Characteristics

The internal 1024 bit EEPROM has the following reliability characteristics-

Table 13 - EEPROM Characteristics

<i>Parameter Description</i>	<i>Value</i>	<i>Unit</i>
Data Retention	15	Years
Read / Write Cycles	100,000	Cycles

### 5.4 Internal Clock Characteristics

The internal Clock Oscillator has the following characteristics.

Table 14 - Internal Clock Characteristics

<i>Parameter</i>	<i>Value</i>			<i>Unit</i>
	<i>Min</i>	<i>Typical</i>	<i>Max</i>	
Frequency of Operation	11.98	12.00	12.02	MHz
Clock Period	83.19	83.33	83.47	ns
Duty Cycle	45	50	55	%

## 6. Module Configurations

### 6.1 Bus Powered Configuration

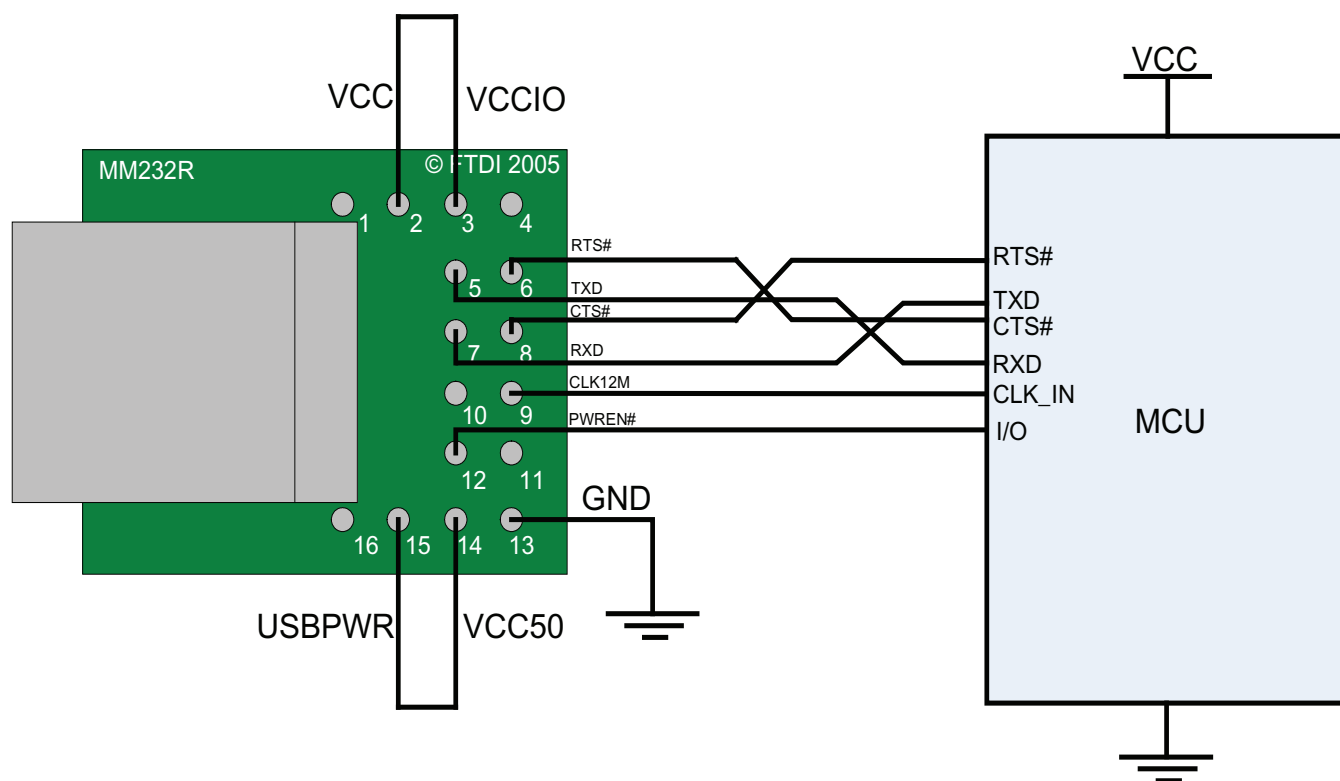

Figure 5 - Bus Powered Configuration

Figure 5 illustrates the MM232R in a typical USB bus powered design configuration. This is done by connecting pin 15 (USBPWR) to pin 14 (VCC50). Pin 3 (VCCIO), the supply to the FT232RQ's UART and CBUS IO pins, is connected to pin 2 (VCC). Doing this will make the UART and CBUS IO pins drive out at 5V levels.

A USB Bus Powered device gets its power from the USB bus. Basic rules for USB Bus power devices are as follows –

- i) On plug-in to USB, the device must draw no more than 100mA.
- ii) On USB Suspend the device must draw no more than 500µA.
- iii) A Bus Powered High Power USB Device (one that draws more than 100mA) should use PWREN# to keep the current below 100mA on plug-in and 500µA on USB suspend.
- iv) A device that consumes more than 100mA can not be plugged into a USB Bus Powered Hub.
- v) No device can draw more that 500mA from the USB Bus.

Figure 5 also illustrates interfacing the MM232R module to a microcontroller (MCU) UART interface. This example uses TXD and RXD for transmission and reception of data, and RTS# / CTS# hardware handshaking. Also in this example the 12MHz clock output on pin 9 is used to clock the MCU.

If the MCU is handling power management functions, then this can be done by connecting PWREN# to an I/O pin on the MCU.



## 6.2 Self Powered Configuration

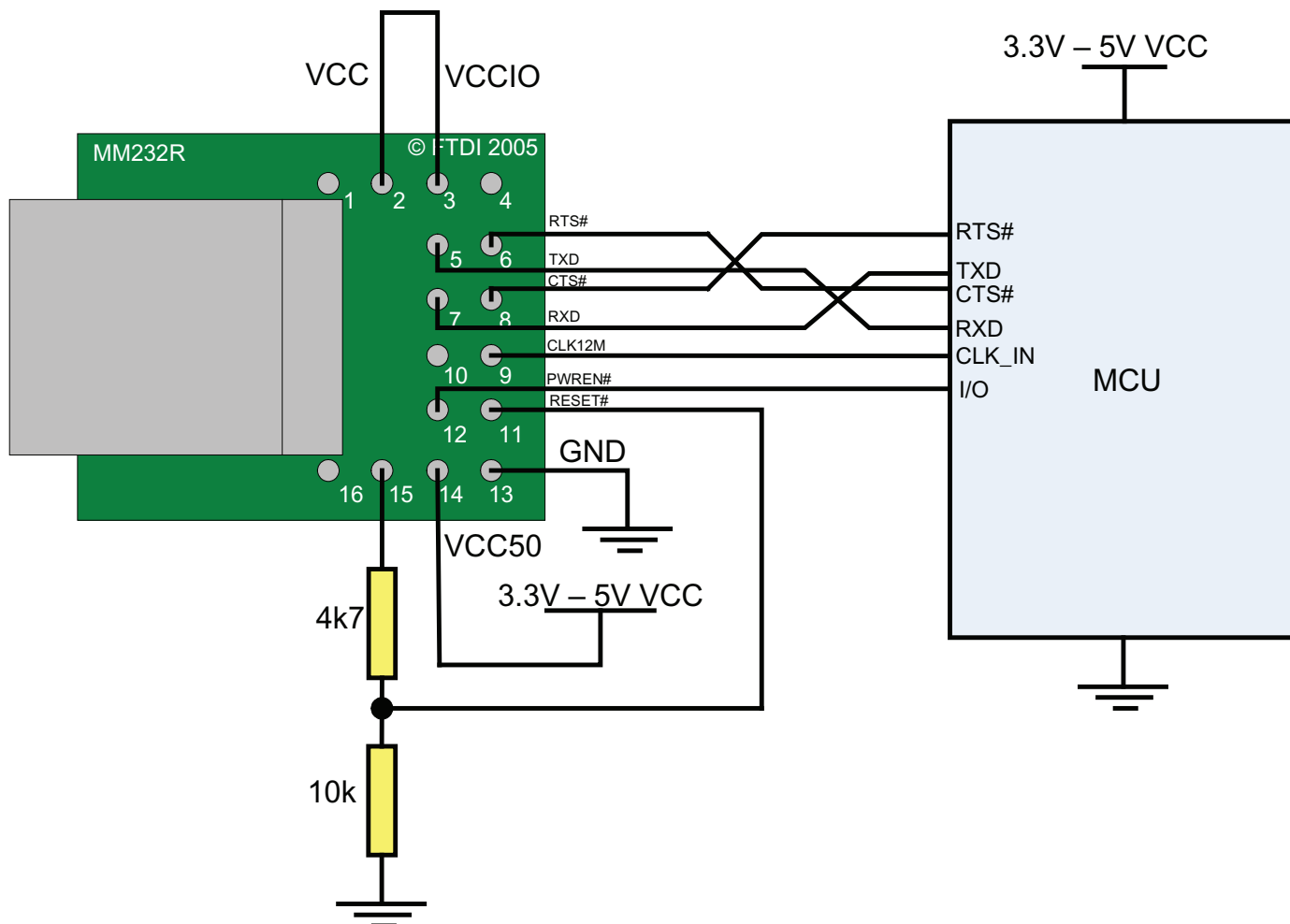

Figure 6 - Self Powered Configuration

Figure 6 illustrates the MM232R in a USB self powered configuration. In this case an external supply is connected to the VCC50 pin. In this example pin 3 (VCCIO), the supply to the FT232RQ's UART and CBUS IO pins, is connected to pin 2 (VCC). Doing this will make the UART and CBUS IO pins drive out at the same voltage level as VCC50. The configuration shown in Figure 5 can have a 3.3V - 5V supply.

A USB Self Powered device gets its power from its own power supply and does not draw current from the USB bus. The basic rules for USB Self powered devices are as follows –

- i) A Self Powered device should not force current down the USB bus when the USB Host or Hub Controller is powered down.
- ii) A Self Powered Device can use as much current as it likes during normal operation and USB suspend as it has its own power supply.
- iii) A Self Powered Device can be used with any USB Host and both Bus and Self Powered USB Hubs

In this case the power descriptor in the internal EEPROM should be programmed to a value of zero (self powered).

In order to meet requirement (i) the USB Bus Power is used to control the RESET# input pin of the FT232R device. When the USB Host or Hub is powered up the internal 1.5kΩ resistor on USBDP is pulled up to 3.3V, thus identifying the device as a full speed device to USB. When the USB Host or Hub power is off, RESET# will go low and the device will be held in reset. As RESET# is low, the internal 1.5kΩ resistor will not be pulled up to 3.3V, so no current will be forced down USBDP via the 1.5kΩ pull-up resistor when the host or hub is powered down. To do this pin 14 (USB) is connected to PU2 and PU1 is connected to RST#. Failure to do this may cause some USB host or hub controllers to power up erratically.

Note : When the FT232R is in reset, the UART interface pins all go tri-state. These pins have internal 200kΩ pull-up resistors to VCCIO, so they will gently pull high unless driven by some external logic.

### 6.3 USB Bus Powered with Power Switching Configuration

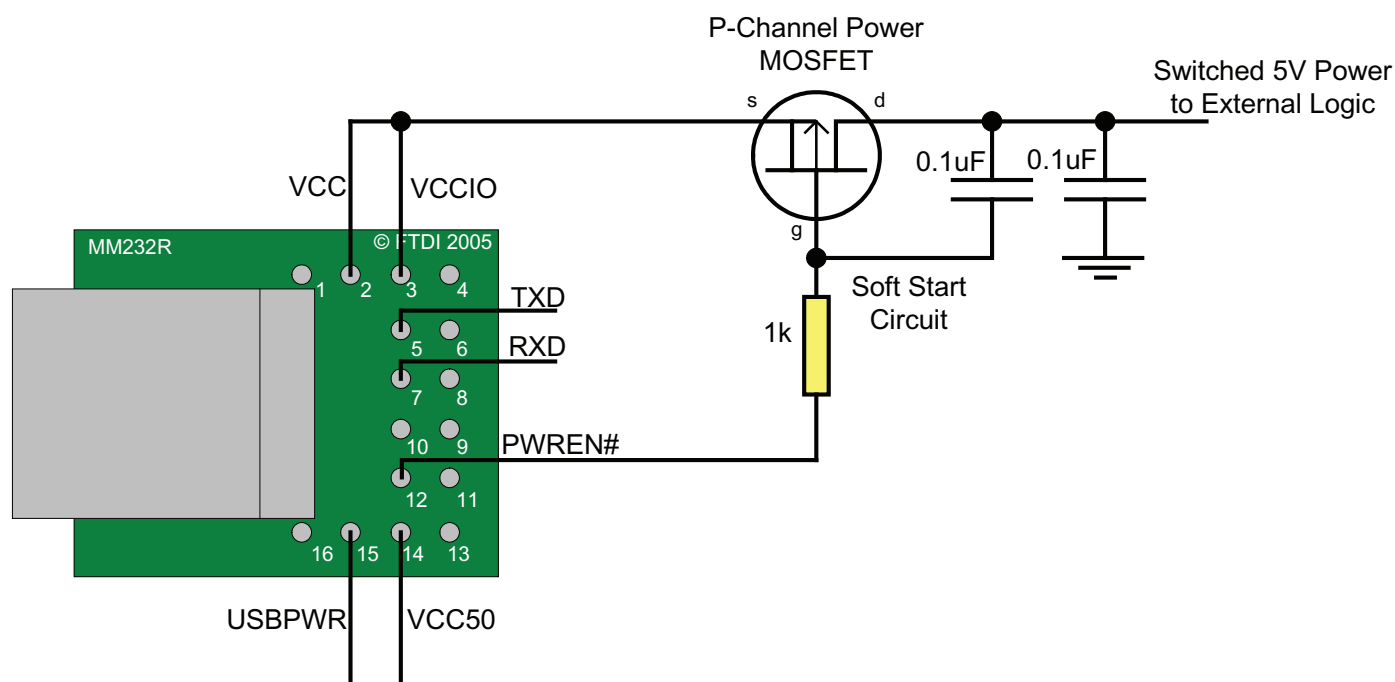

Figure 7 - Bus Powered with Power Switching Configuration

USB Bus powered circuits need to be able to power down in USB suspend mode in order to meet the  $\leq 500\mu\text{A}$  total USB suspend current requirement (including external logic). Some external logic can power itself down into a low current state by monitoring the PWREN# signal. For external logic that cannot power itself down in this way, the FT232R provides a simple but effective way of turning off power to external circuitry during USB suspend.

Figure 7 shows how to use a discrete P-Channel Logic Level MOSFET to control the power to external logic circuits. A suitable device would be an International Rectifier ([www.irf.com](http://www.irf.com)) IRLML6402, or equivalent. It is recommended that a “soft start” circuit consisting of a  $1\text{k}\Omega$  series resistor and a  $0.1\mu\text{F}$  capacitor are used to limit the current surge when the MOSFET turns on. Without the soft start circuit there is a danger that the transient power surge of the MOSFET turning on will reset the FT232R, or the USB host / hub controller. The values used here allow attached circuitry to power up with a slew rate of  $\sim 12.5\text{V}$  per millisecond, in other words the output voltage will transition from GND to 5V in approximately 400 microseconds.

Alternatively, a dedicated power switch I.C. with inbuilt “soft-start” can be used instead of a MOSFET. A suitable power switch I.C. for such an application would be a Micrel ([www.micrel.com](http://www.micrel.com)) MIC2025-2BM or equivalent.

Please note the following points in connection with power controlled designs –

- i) The logic to be controlled must have its own reset circuitry so that it will automatically reset itself when power is re-applied on coming out of suspend.
- ii) Set the Pull-down on Suspend option in the internal EEPROM.
- iii) The PWREN# pin should be used to switch the power supply to the external circuitry.
- iv) For USB high-power bus powered device (one that consumes greater than  $100\text{mA}$ , and up to  $500\text{mA}$  of current from the USB bus), the power consumption of the device should be set in the max power field in the internal EEPROM. A high-power bus powered device must use this descriptor in the internal EEPROM to inform the system of its power requirements.
- v) For 3.3V power controlled circuits the VCCIO pin must not be powered down with the external circuitry (the PWREN# signal gets its VCC supply from VCCIO). Either connect the power switch between the output of the 3.3V regulator and the external 3.3V logic or power VCCIO from the 3V3OUT pin of the FT232R.

## 6.4 USB Bus Powered with 3.3V Logic Drive / IO Supply Voltage

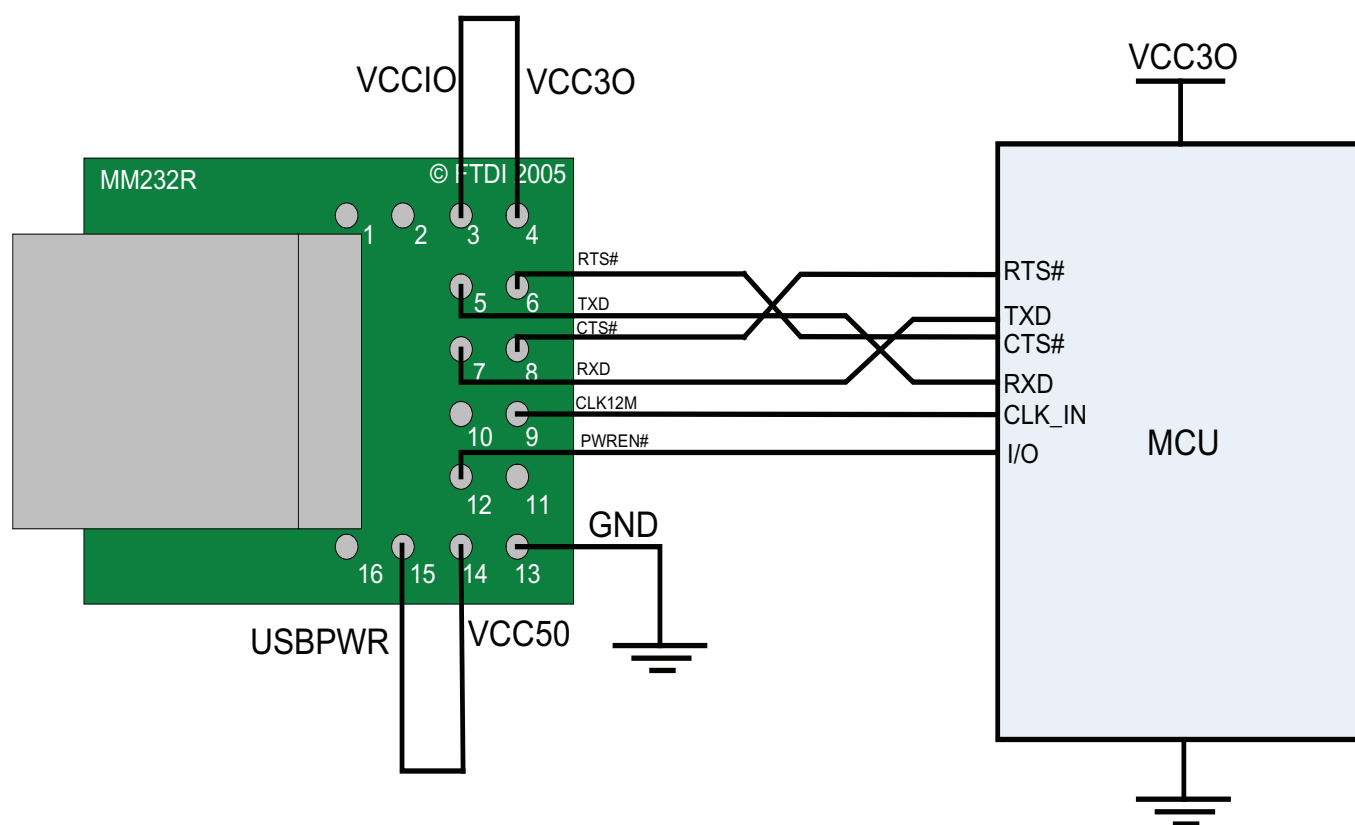

Figure 8 - Bus Powered with 3.3V Logic Drive

Figure 8 shows a configuration where the MM232R module has been configured to be interfaced with a 3.3V MCU. To do this the MM232R's VCCIO pin is connect to VCC30. The MM232R's VCC30 pin can also be used to supply up to 50mA to external logic.

Please note the following in relation to bus powered designs of this type -

- i) PWREN# or SLEEP# signals should be used to power down external logic during USB suspend mode, in order to comply with the limit of 500 $\mu$ A. If this is not possible, use the configuration shown in [Section 6.3](#).
- ii) The maximum current source from USB Bus during normal operation should not exceed 100mA, otherwise a bus powered design with power switching ([Section 6.3](#)) should be used.

Another possible configuration would be to use a discrete low dropout regulator which is supplied by the 5V on the USB bus to supply 2.8V - 1.8V to the VCCIO pin and to the external logic. The LDO would be supplied with the 5V from the USB bus (available from the module's USBPWR pin). VCCIO would be connected to the output of the low dropout regulator, would in turn will cause the MM232R I/O pins to drive out at 2.8V - 1.8V logic levels.

For USB bus powered circuits some considerations have to be taken into account when selecting the regulator –

- iii) The regulator must be capable of sustaining its output voltage with an input voltage of 4.35V. A Low Drop Out (L.D.O.) regulator must be selected.
- iv) The quiescent current of the regulator must be low in order to meet the USB suspend total current requirement of  $\leq 500\mu$ A during USB suspend.

An example of a regulator family that meets these requirements is the MicroChip / Telcom TC55 Series of devices ([www.microchip.com](http://www.microchip.com)). These devices can supply up to 250mA current and have a quiescent current of under 1 $\mu$ A.

## 7. Module Circuit Schematic

Figure 8 - Module Circuit Schematic

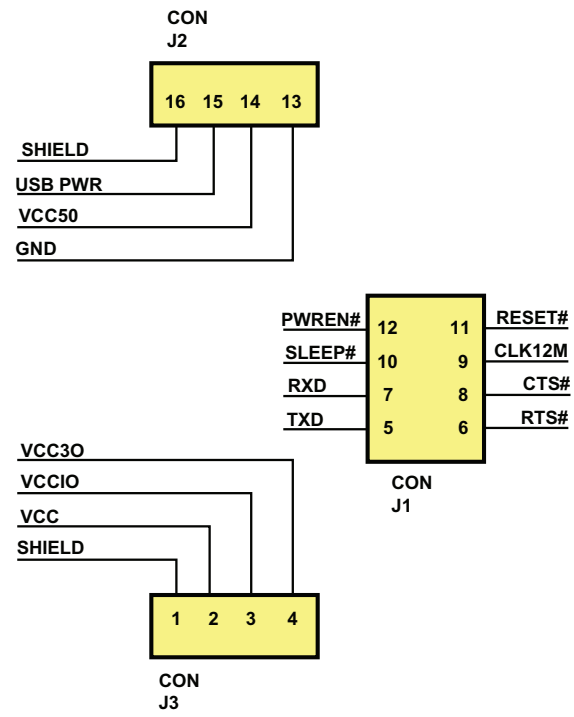
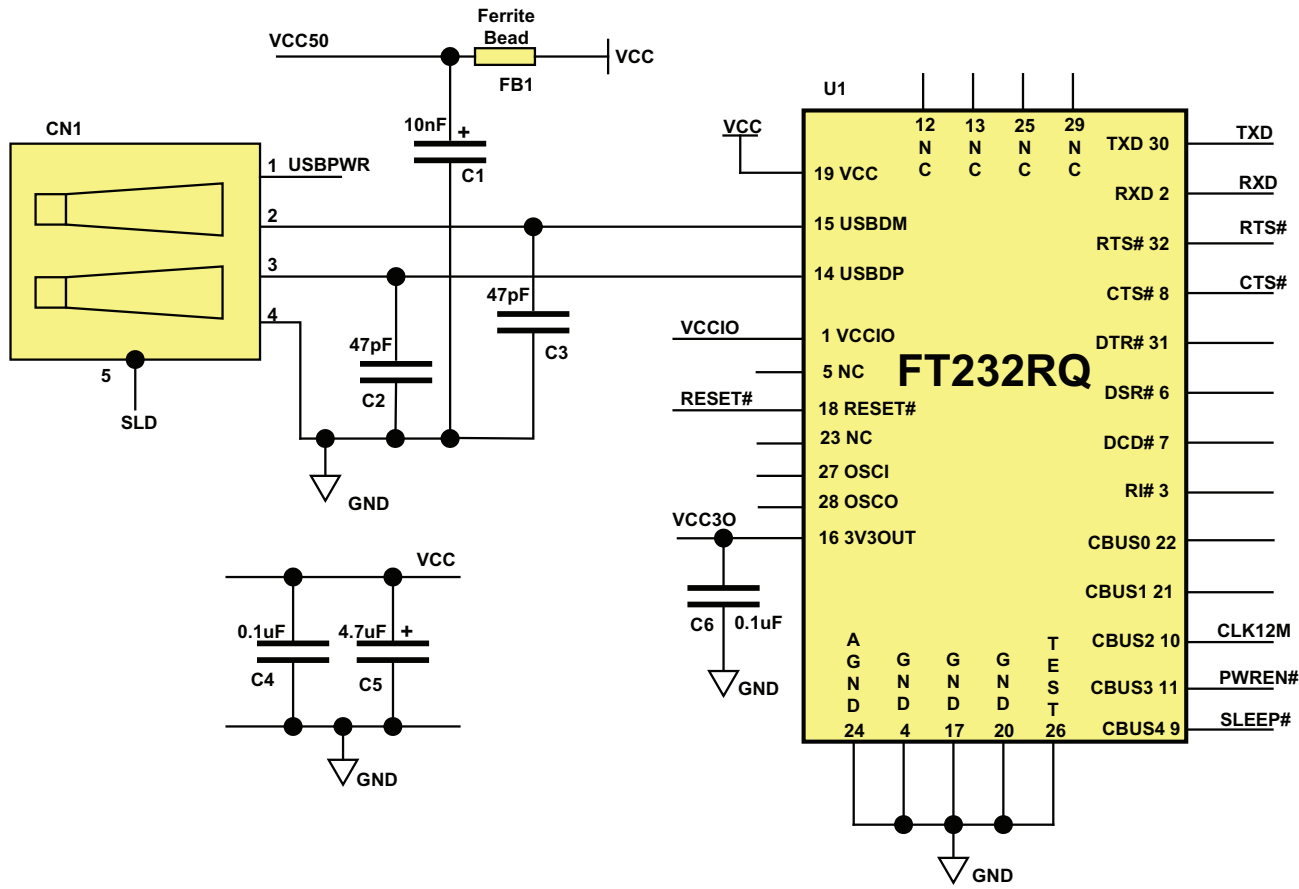

## 8. Internal EEPROM Configuration

Following a power-on reset or a USB reset the FT232R will scan its internal EEPROM and read the USB configuration descriptors stored there. The default values programmed into the internal EEPROM in the FT232RQ used on the MM232R are shown in Table 17.

Table 17 - Default Internal EEPROM Configuration

Parameter	Value	Notes
USB Vendor ID (VID)	0403h	FTDI default VID (hex)
USB Product ID (PID)	6001h	FTDI default PID (hex)
Serial Number Enabled?	Yes	
Serial Number	See Note	A unique serial number is generated and programmed into the EEPROM during final test of the MM232R module.
Pull Down I/O Pins in USB Suspend	Disabled	Enabling this option will make the device pull down on the UART interface lines when the power is shut off (PWREN# is high)
Manufacturer Name	FTDI	
Manufacturer ID	FT	
Product Description	MM232R USB Module	
Max Bus Power Current	90mA	
Power Source	Bus Powered	
Device Type	FT232R	
USB Version	0200	Returns USB 2.0 device descriptor to the host. Note: The device is be a USB 2.0 Full Speed device (12Mb/s) as opposed to a USB 2.0 High Speed device (480Mb/s).
Remote Wake up	Enabled	Taking RI# low will wake up the USB host controller from suspend.
High Current I/Os	Disabled	Enables the high drive level on the UART and CBUS I/O pins
Load VCP Driver	Enabled	Makes the device load the VCP driver interface for the device.
CBUS0	TXDEN#	Default configuration of CBUS0 - Transmit Data Enable for RS485. This FT232RQ pin is not bought out on the MM232R module.
CBUS1	TXDEN#	Default configuration of CBUS1 - Transmit Data Enable for RS485. This FT232RQ pin is not bought out on the MM232R module.
CBUS2	12MOUT	Default configuration of CBUS2 - 12MHz Clock Output.
CBUS3	PWREN#	Default configuration of CBUS3 - Power enable. Low after USB enumeration, high during USB suspend.
CBUS4	SLEEP#	Default configuration of CBUS4 - Low during USB suspend.
Invert TXD	Disabled	Signal on this pin becomes TXD# if enabled.
Invert RXD	Disabled	Signal on this pin becomes RXD# if enabled.
Invert RTS#	Disabled	Signal on this pin becomes RTS if enabled.
Invert CTS#	Disabled	Signal on this pin becomes CTS if enabled.
Invert DTR#	Disabled	Signal on this pin becomes DTR if enabled.
Invert DSR#	Disabled	Signal on this pin becomes DSR if enabled.
Invert DCD#	Disabled	Signal on this pin becomes DCD if enabled.
Invert RI#	Disabled	Signal on this pin becomes RI if enabled.

The internal EEPROM in the FT232R can be programmed over USB using the utility program MPROG. MPROG can be downloaded from the [FTDI website](#). Version 2.8a or later is required for the FT232R chip. Users who do not have their own USB Vendor ID but who would like to use a unique Product ID in their design can apply to FTDI for a free block of unique PIDs. Contact [FTDI support](#) for this service.

## Disclaimer

---

### Copyright © Future Technology Devices International Limited , 2005.

Version 0.91 - Initial Datasheet Created December 2005

Version 1.00 - Full release January 2006

Neither the whole nor any part of the information contained in, or the product described in this manual, may be adapted or reproduced in any material or electronic form without the prior written consent of the copyright holder.

This product and its documentation are supplied on an as-is basis and no warranty as to their suitability for any particular purpose is either made or implied.

Future Technology Devices International Ltd. will not accept any claim for damages howsoever arising as a result of use or failure of this product. Your statutory rights are not affected.

This product or any variant of it is not intended for use in any medical appliance, device or system in which the failure of the product might reasonably be expected to result in personal injury.

This document provides preliminary information that may be subject to change without notice.

### Contact FTDI

#### Head Office -

##### Future Technology Devices International Ltd.

373 Scotland Street,  
Glasgow G5 8QB,  
United Kingdom

Tel. : +(44) 141 429 2777

Fax. : +(44) 141 429 2758

E-Mail (Sales) : [sales1@ftdichip.com](mailto:sales1@ftdichip.com)

E-Mail (Support) : [support1@ftdichip.com](mailto:support1@ftdichip.com)

E-Mail (General Enquiries) : [admin1@ftdichip.com](mailto:admin1@ftdichip.com)

#### Regional Sales Offices -

##### Future Technology Devices International Ltd. (Taiwan)

4F, No 16-1,  
Sec. 6 Mincyuan East Road,  
Neihu District,  
Taipei 114,  
Taiwan, R.o.C.

Tel.: +886 2 8791 3570

Fax: +886 2 8791 3576

E-Mail (Sales): [tw.sales@ftdichip.com](mailto:tw.sales@ftdichip.com)

E-Mail (Support): [tw.support@ftdichip.com](mailto:tw.support@ftdichip.com)

E-Mail (General Enquiries): [tw.admin@ftdichip.com](mailto:tw.admin@ftdichip.com)

##### Future Technology Devices International Ltd. (USA)

5285 NE Elam Young  
Parkway, Suite B800  
Hillsboro,  
OR 97124-6499  
USA

Tel.: +1 (503) 547-0988

Fax: +1 (503) 547-0987

E-Mail (Sales): [us.sales@ftdichip.com](mailto:us.sales@ftdichip.com)

E-Mail (Support): [us.support@ftdichip.com](mailto:us.support@ftdichip.com)

E-Mail (General Enquiries): [us.admin@ftdichip.com](mailto:us.admin@ftdichip.com)

Website URL : <http://www.ftdichip.com>