



HESTORE.HU

elektronikai alkatrész áruház

EN: This Datasheet is presented by the manufacturer.

Please visit our website for pricing and availability at www.hestore.hu.



Future Technology Devices International Ltd

DB9-USB-RS232 Module

Male & Female

Datasheet

Document Reference No.: FT_000204

Version 1.2

Issue Date: 2010-06-01

Future Technology Devices International Ltd (FTDI)

Unit 1, 2 Seaward Place, Centurion Business Park, Glasgow, G41 1HH, United Kingdom

Tel.: +44 (0) 141 429 2777 Fax: + 44 (0) 141 429 2758

E-Mail (Support): support1@ftdichip.com Web: <http://www.ftdichip.com>

Neither the whole nor any part of the information contained in, or the product described in this manual, may be adapted or reproduced in any material or electronic form without the prior written consent of the copyright holder. This product and its documentation are supplied on an as-is basis and no warranty as to their suitability for any particular purpose is either made or implied. Future Technology Devices International Ltd will not accept any claim for damages howsoever arising as a result of use or failure of this product. Your statutory rights are not affected. This product or any variant of it is not intended for use in any medical appliance, device or system in which the failure of the product might reasonably be expected to result in personal injury. This document provides preliminary information that may be subject to change without notice. No freedom to use patents or other intellectual property rights is implied by the publication of this document. Future Technology Devices International Ltd, Unit1, 2 Seaward Place, Centurion Business Park, Glasgow, G41 1HH, United Kingdom. Scotland Registered Number: SC136640

1 Introduction

1.1 Functional Description

The DB9-USB-RS232 modules are designed to directly replace an existing DB9, the industry accepted name for a DE9 connector, (male or female) RS232 connection with a drop-in USB replacement connection. The modules will replace (pin-for-pin) a male or female DB9 RS232 connector with a USB mini-B connector. The application PCB containing the existing DB9 RS232 connector does not require any modification, only the replacement of the D-type connector with the appropriate DB9-USB-RS232 module. A male DB9 should be replaced by a male DB9-USB-RS232-M and a female DB9 should be replaced by a female DB9-USB-RS232-F. The modules contain all necessary electronics to convert between USB and RS232.

The purposes of the modules is to provide a simple method of adapting legacy serial devices with RS232 interfaces to modern USB ports by replacing the DB9 connector with this miniaturised module which closely resembles a DB9 connector. This is accomplished by incorporating the industry standard FTDI FT232R USB-Serial Bridge IC plus the required level shifters inside the module.



Figure 1.1 – DB9-USB-RS232

The module uses a standard USB-MINI-B connector for connection to an upstream host or hub port. RS232-level signals, including modem handshake signals, can transmit data at rates up to 1 Mega Baud.

The DB9-USB-RS232 module requires USB device drivers, available free from www.ftdichip.com, which are used to make the DB9-USB-RS232 appear as a Virtual COM Port (VCP). This allows existing serial communications software, such as HyperTerminal, to exchange data through the DB9-USB-RS232 to a legacy RS232 peripheral device.

Note: The connector is referred as a DB9 connector since DE9 is often referred to by this name.

1.2 Block Diagram

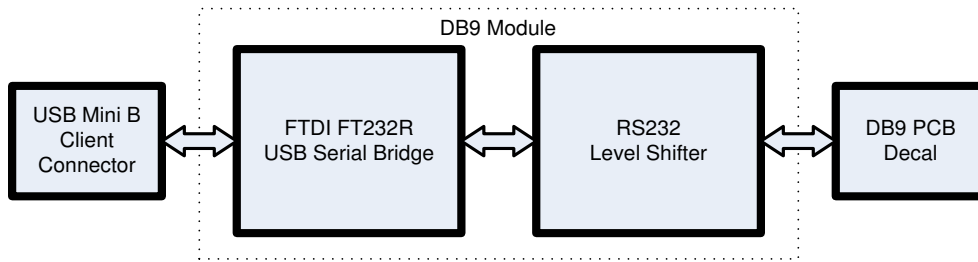

Figure 1.2 – DB9-USB-RS232 Block Diagram

1.2.1 Block description

USB Mini B Client Connector

This connector provides the interface for connection to a USB Host or Hub port.

FTDI FT232R

The FTDI FT232R provides the USB-to-Serial conversion. Operating system device drivers are required in order to operate with the FT232R to provide the Virtual COM Port serial functionality.

RS232 Level Shifter

The RS232 level shifter converts the signals provided by the FT232R into the voltage levels required by application RS232 interface.

DB9 PCB Footprint

The DB9 pin-out configured in an industry standard (TIA/EIA-574) pin-out to provide connection to RS232 peripherals through a standard DB9 footprint . See section 2.1.2

1.3 Features

- Adds one USB serial port by connecting to the RS232 DB9 footprint of a device
- Easy placement for an standard Male and Female RS232 DB9 footprint of a device
- Works with USB 1.1 & 2.0 Host and Hub ports
- Industry Standard FTDI chip set & device drivers for maximum compatibility
- Microsoft Windows® WHQL-certified, Mac OS X, Linux and Windows CE device drivers
- Installs as a standard Windows COM port
- Supports Windows Server 2008, 2003, Vista, XP 2000, Linux, Mac OS X
- 128 byte transmit buffer, 256 byte receive buffer
- RS-232 data signals: TxD, RxD, RTS, CTS, DSR, DTR, DCD, RI, GND
- Powered by USB port. No external power adapter required.
- Serial port speed up to 1Mbps
- Serial Communication Parameters
 - Parity: None, Even, Odd
 - Data bits: 7, 8
 - Flow control: RTS/CTS , DSR/DTR, X-ON/X-OFF, None
- Operating temperature of -40°C to +85°C

1.4 Performance Figures

Parameter	Performance
USB Interface	12Mbps USB 2.0 Full-Speed
RS232 Interface	Standard Windows baud rates (300bps to 921.6Kbps) Custom baud rates (300bps to 1Mbps) through baud rate aliasing. See FTDI Application Note: Configuring FT232R, FT2232 and FT232BM Baud Rates

Table 1.1 – Performance Specifications

Part Number	Description
DB9-USB-M	Full Speed USB to 1-Port RS232 module to replace RS232 DB9 male connector
DB9-USB-F	Full Speed USB to 1-Port RS232 module to replace RS232 DB9 female connector

Table 1.2 – Ordering Information

1	Introduction	1
1.1	Functional Description	1
1.2	Block Diagram	2
1.2.1	Block description	2
1.3	Features	3
1.4	Performance Figures	3
2	Connections	5
2.1	External Connections	5
2.1.1	USB	5
2.1.2	Replacing an RS232 DB9 MALE (DTE defined) Connector	6
2.1.3	Replacing an RS232 DB9 FEMALE (DCE defined) Connector	8
3	Installation	10
3.1	Device Driver Installation	10
3.1.1	Microsoft Windows Installation	10
3.1.2	Mac OS X, Linux, Windows CE	14
4	Electrical details	15
4.1	USB	15
4.2	RS232	15
5	Mechanical Details	16
6	Physical Environment Details	17
6.1	Storage	17
6.2	Operating	17
7	Environmental Approvals & Declarations	18
7.1	EMI Compatibility	18
7.2	Safety	18
7.3	Environmental	18
7.4	Reliability	18
7.4.1	MTTF	18
7.5	Import / Export Information	19
8	Troubleshooting	20
9	Contact Information	21
	Appendix A – List of Figures and tables	23
	Appendix B – DCE and DTE Wire Configurations	24
B.1	Wire Configuration for the Male and Female Modules	24
B.1.1	RS232 Wiring	24
	Appendix C – Revision History	26

2 Connections

2.1 External Connections

2.1.1 USB

The DB9-USB-RS232 module is a downstream USB 2.0 Device. A "USB mini B" receptacle is mounted inside the module to facilitate connection to an upstream USB Host or Hub.

Pin Number	Pin Type	Description
1	Power	VBUS – USB Power provided from upstream USB Host or Hub
2	Bidirectional	D- = USB data signal, negative polarity
3	Bidirectional	D+ = USB data signal, positive polarity
4	ID	Not Connected
5	Ground	GND = USB signal ground
Shield	Case Ground	Drain = typically connected to the host PC case

Table 2.1 – USB "mini-B" Receptacle Pin-Out

2.1.2 Replacing an RS232 DB9 MALE (DTE defined) Connector

The DB9-USB-RS232-M can be used to replace a male DB9 connector used for transmitting RS232 protocol. With the DB9-USB-RS232-M in place instead of the standard USB connector a USB bridge is created, this allow the application to communicate with other devices via USB. Installing the DB9-USB-RS232-M is simple. Simply replace the male DB9 connector with the DB9-USB-RS232-M connector (same PCB footprint), install drivers and the device is ready to use.

Table 2.2 gives the pin out description of each pad of an RS232 footprint. Figure 2.2 gives a description of the connections between the DB9-USB-RS232-M and the footprint of a male DB9 module.

Pin Number	Pin Type of DB9-USB-RS232 module	Pin Type at application PCB	Description
1	Input (note1)	Input	DCD = Data Carrier Detect
2	Output	Input	RXD = Receive Data (this is an output from the DB9-USB-RS232-M to the application Rx input)
3	Input	Output	TXD = Transmit Data (this is an input to the DB9-USB-RS232-M from the application Tx output)
4	Input	Output	DTR = Data Terminal Ready (this is an input to the DB9-USB-RS232-M from the application DTR output)
5	Ground	Ground	GND = RS232 signal ground
6	Output	Input	DSR = Data Set Ready (this is an output from the DB9-USB-RS232-M to the application DSR input)
7	Input	Output	RTS = Request To Send (this is an input to the DB9-USB-RS232-M from the application RTS output)
8	Output	Input	CTS = Clear To Send (this is an output from the DB9-USB-RS232-M to the application CTS input)
9	Input (note1)	Input	RI = Ring Indicator
Shield	Ground	Case Ground	Drain = typically connected to the host PC case

Table 2.2 – A Male RS232 DB9 footprint Pin-Out

Note 1: The DB9-USB-RS232-M is electrically configured to be a DTE (Data Terminating Equipment) device with a null-modem wiring. The null-modem wiring allows DTE to DTE communications between the DB9-USB-RS232-M and a standard DB9 male application board. However a DTE device is defined to have 5 inputs and 3 outputs, where a DCE (Data Communications Equipment) is defined to have 3 inputs and 5 outputs as in the case of the female DB9 application boards. This leads to a conflict in an DTE to DTE connection application, This conflict is that there are more inputs to a connected USB-converter device than there are outputs from the application board (and more inputs to the application board than there are outputs of the USB converter). This conflict occurs on the DCD and RI connections and as such they cannot be used. This issue is very common when translating RS232 to USB from a DTE perspective. Additional information showing DTE and DCE wiring is given in Appendix B.

Figure 2.1 illustrates these connections from a PCB footprint point of view. Figure 2.2 Illustrates the connection made to an example PCB.

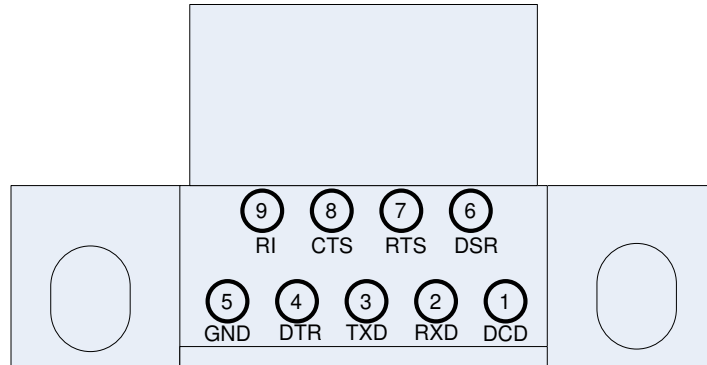

Figure 2.1 – DB9-USB-RS232-M Pin-Out from a Top View through the module

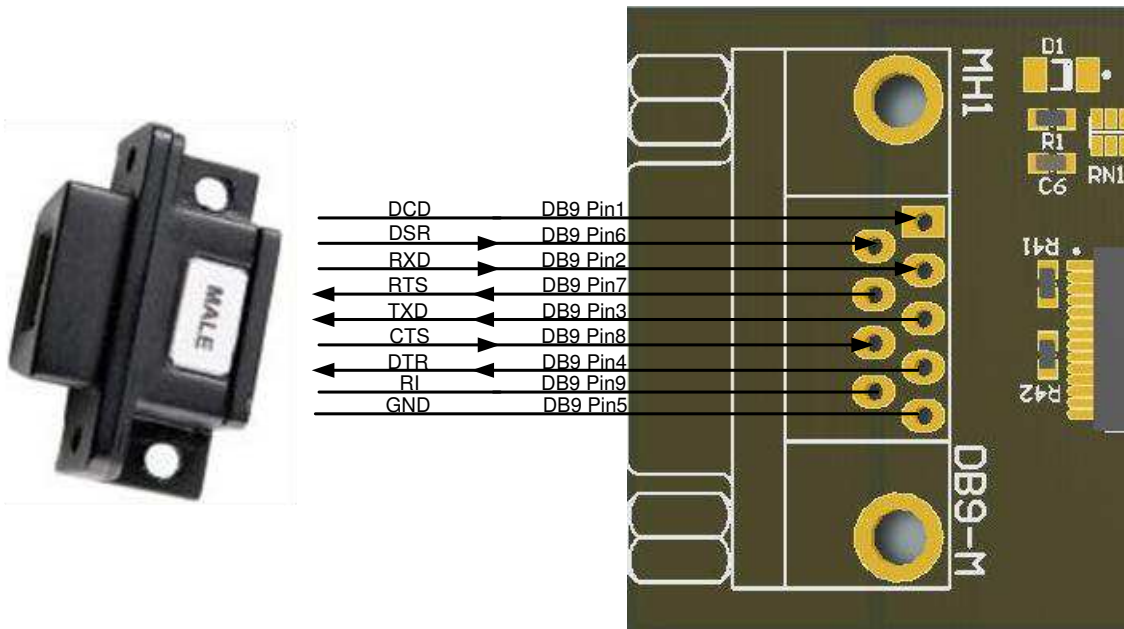

Figure 2.2 – DB9-USB-RS232-M Connection illustration

2.1.3 Replacing an RS232 DB9 FEMALE (DCE defined) Connector

The DB9-USB-RS232-F can be used to replace a female DB9 connector used for transmitting RS232 protocol. With the DB9-USB-RS232-F in place instead of the standard USB connector a USB bridge is created, this allow the application to communicate with other devices via USB. Installing the DB9-USB-RS232-F is simple. Simply replace the female DB9 connector with the DB9-USB-RS232-F connector (same PCB footprint), install drivers and the device is ready to use.

Table 2.3 gives the pin out description of each pad of an RS232 footprint. Figure 2.3 gives a description of the connections between the DB9-USB-RS232-F and the footprint of a female DB9 module. Figure 2.4 Illustrates the connection made to an example PCB.

Pin Number	Pin Type of DB9-USB-RS232 module	Pin Type at application PCB	Description
1	Input	Output	DCD = Data Carrier Detect (this is an input to the DB9-USB-RS232-F from the application DCD output)
2	Input	Output	RXD = Receive Data (this is an input to the DB9-USB-RS232-F from the application Tx output, normally labelled RXD in DCE convention)
3	Output	Input	TXD = Transmit Data (this is an output to the DB9-USB-RS232-F from the application Rx input, normally labelled TXD in DCE convention)
4	Output	Input	DTR = Data Terminal Ready (this is an output to the DB9-USB-RS232-F from the application DSR input, normally labelled DTR in DCE convention)
5	Ground	Ground	GND = RS232 signal ground
6	Input	Output	DSR = Data Set Ready (this is an input to the DB9-USB-RS232-F from the application DTR output, normally labelled DSR in DCE convention)
7	Output	Input	RTS = Request To Send (this is an output to the DB9-USB-RS232-F from the application CTS input, normally labelled RTS in DCE convention)
8	Input	Output	CTS = Clear To Send (this is an input to the DB9-USB-RS232-F from the application RTS output, normally labelled CTS in DCE convention)
9	Input	Output	RI = Ring Indicator (this is an input to the DB9-USB-RS232-F from the application RI output)
Shield	Ground	Case Ground	Drain = typically connected to the host PC case

Table 2.3 – A Female RS232 DB9 footprint Pin-Out

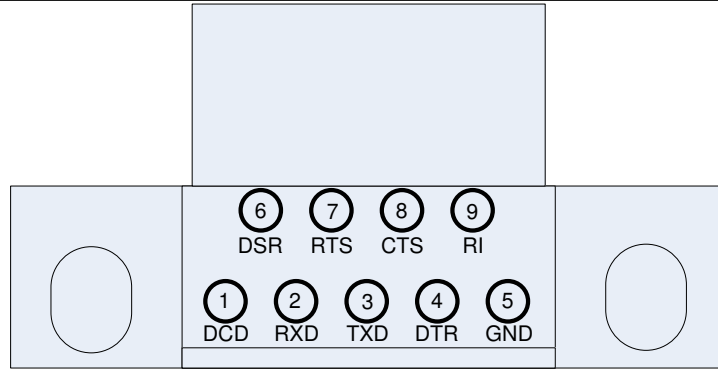

Figure 2.3 – DB9-USB-RS232-F Pin-Out from a Top View through the module

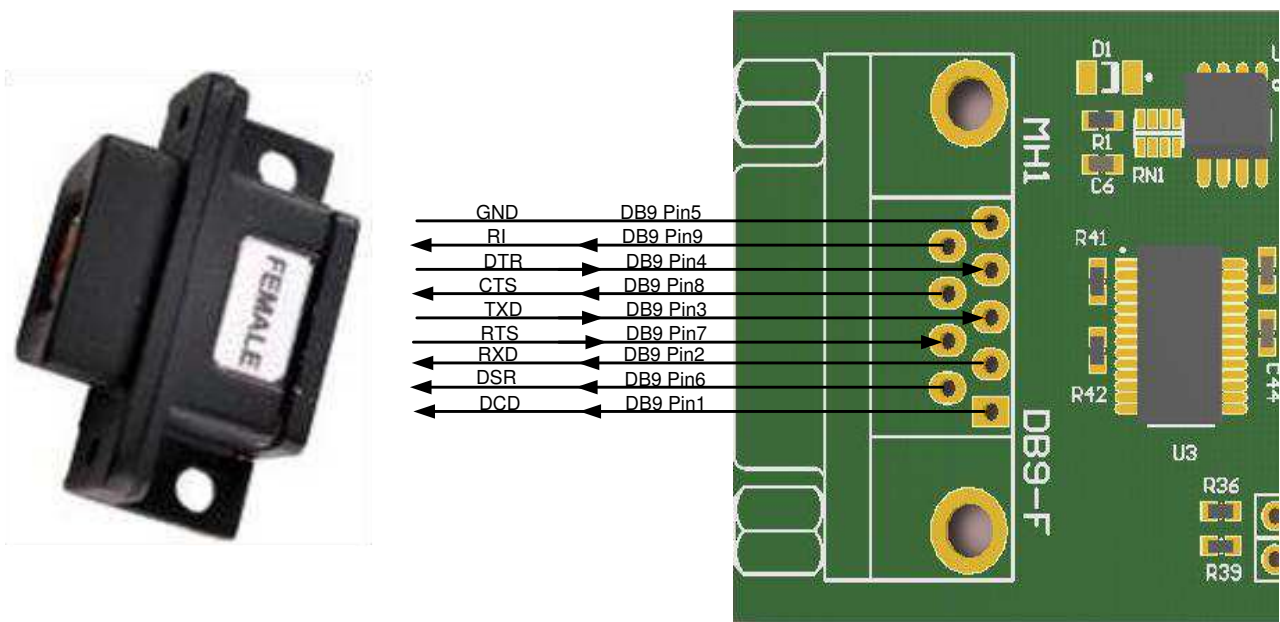

Figure 2.4 – DB9-USB-RS232-F Connection illustration

3 Installation

3.1 Device Driver Installation

The drivers for the DB9-USB-RS232 modules are available for download from:

www.ftdichip.com

The following section illustrates an example installation on the Windows OS.

3.1.1 Microsoft Windows Installation

With the device drivers being Windows Hardware Quality Labs (WHQL) certified, they are also available through download directly from the Microsoft® Windows® Update service. Additional installation options are noted below:

Installation Executable shown on Windows XP

- 1) Login to the system as Administrator, or a user with Administrator rights.
- 2) Prior to connecting the DB9-USB-RS232 module to the USB Host or Hub port, download the latest device driver version from the FTDIChip web site.
- 3) Run this executable to install the device drivers.
- 4) Connect the DB9-USB-RS232 module to your computer. A notification will appear near the task bar indicating that new hardware has been installed and is ready for use. It is normal if this notice appears twice.

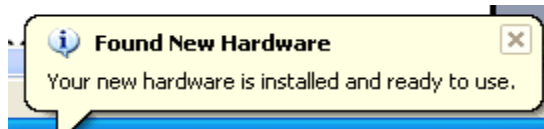

Figure 3.1 – Hardware Ready

Windows Update shown on Windows XP

You must have an active Internet connection and the Windows Update Service enabled.

- 1) Connect the DB9-USB-RS232 module to your USB Host or Hub.
- 2) The “Found New Hardware” Wizard will appear. The first dialog should ask whether it is acceptable to use the Windows Update Service to find the device driver.



Figure 3.2 – Found New Hardware Wizard

- 3) Select one of the “Yes” choices and click “Next”.

- 4) The following screen appears:



Figure 3.3 – Automatic Install

- 5) Wait while the driver is found, downloaded, and installed. This step may take a couple minutes depending on the Internet speed.
- 6) After the files are found and installed, click "Finish" to complete the installation.

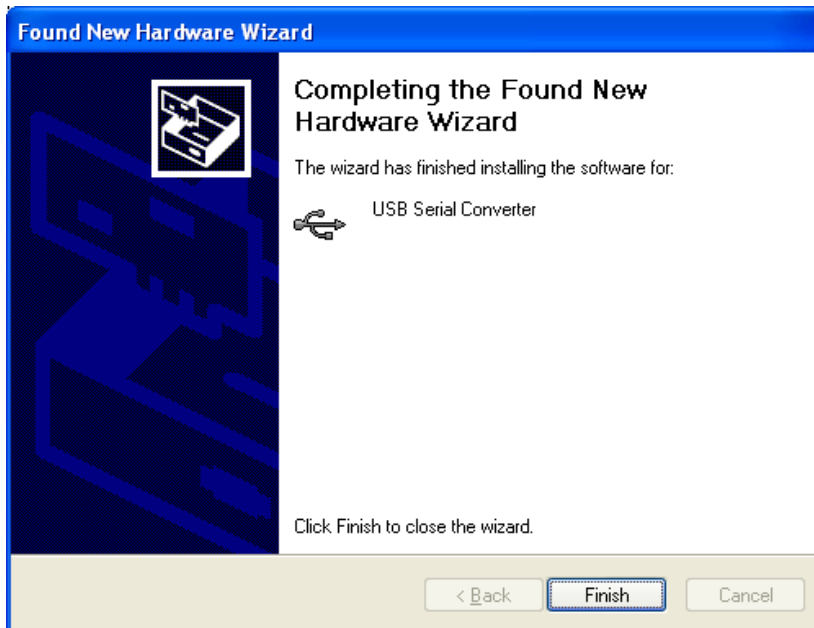

Figure 3.4 – Complete Hardware Installation

- 7) Steps 2 through 6 will repeat. The first time installs the basic USB Serial Converter in the USB device tree. The second time installs the Virtual COM Port layer in the Ports tree and assigns the COM port number.
- 8) When both portions of the device driver have been installed successfully, the following message will appear, indicating that the device is ready.

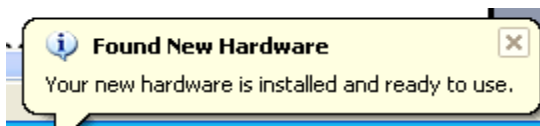

Figure 3.5 – Hardware Ready

COM Port Assignment

Next, to determine which COM port has been assigned, open the Windows Device Manager from the System Control Panel.

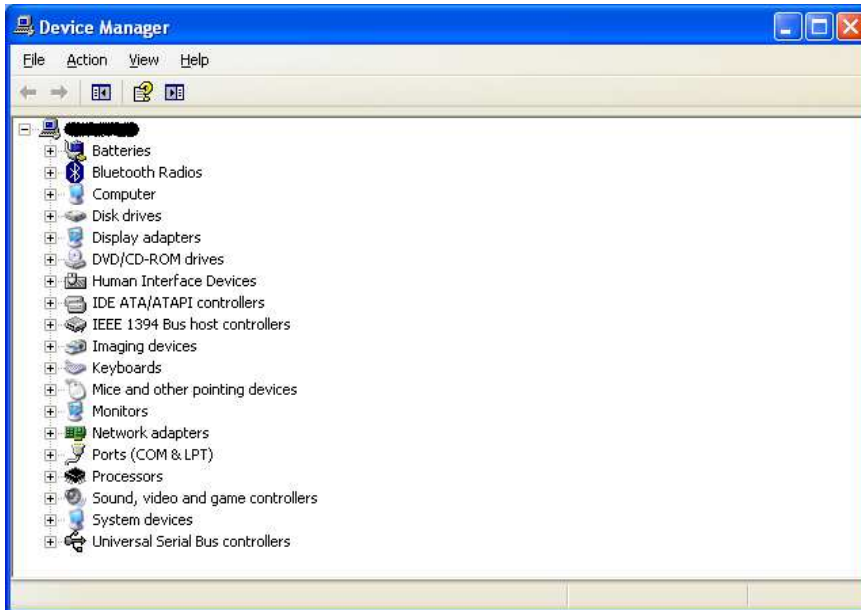

Figure 3.6 – Device Manager

Click on the Plus "+" sign next to the Ports tree to list the available COM port. You will see "USB Serial Port", followed by a COMn assignment. In the figure below, the DB9-USB-RS232 module is assigned to COM3.



Figure 3.7 – COM Port Assignment

Use this COM port number with your application software in order to access the DB9-USB-RS232 module.

If an application requires use of a different COM port number, the assignment may be changed through the Advanced Driver Options settings.

From the Device Manager listing above, right-click on the USB Serial Port and select Properties.



Figure 3.8 – Access COM Port Properties

Next, click on the "Port Settings" tab.

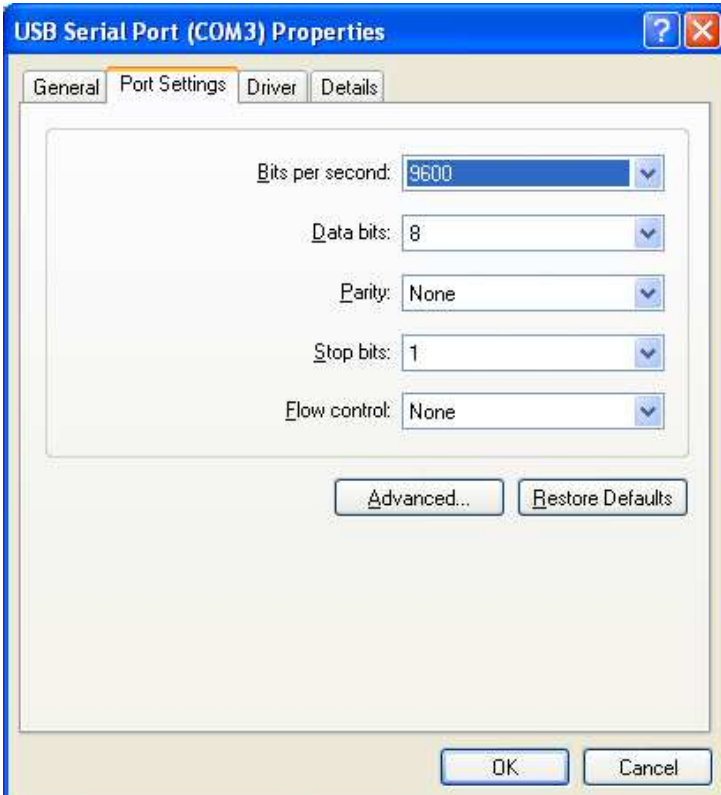

Figure 3.9 – Settings Tab

Then click on the "Advanced..." button.

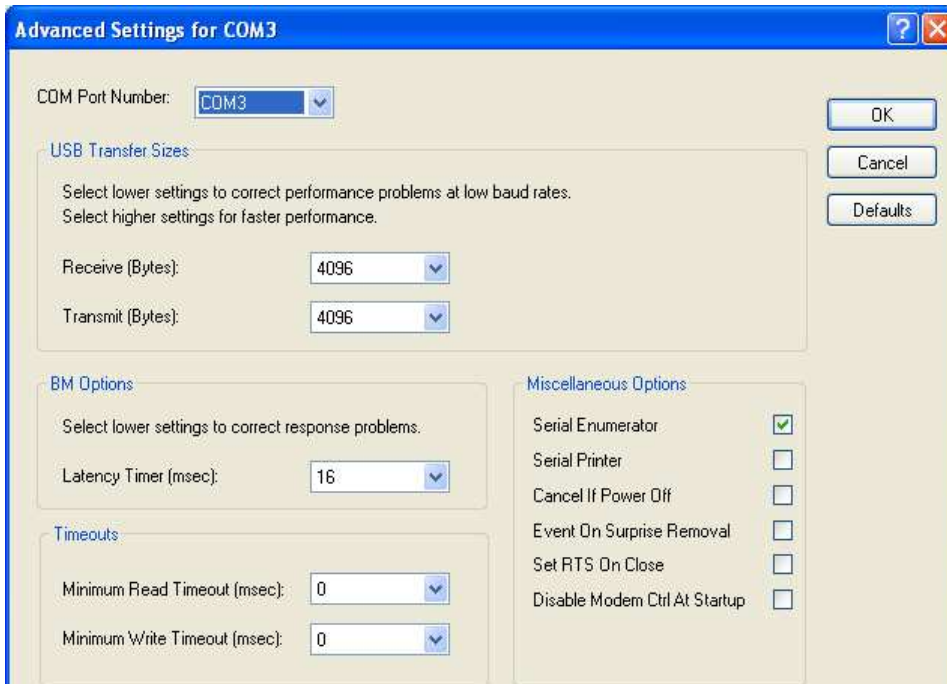

Figure 3.10 – Advanced Options

This will display the various advanced settings. Note the COM port assignment in the upper left. Clicking on the drop-down list will display the available port numbers. Select one that is not in use and click OK on each dialog box to activate the selection. Windows will remember this COM port number.

3.1.2 Mac OS X, Linux, Windows CE

Device drivers and FTDI installation guides for Mac OS X, Linux and Windows CE are available for download on the FTDIChip web sites. Follow the respective FTDI installation guides for the chosen operating system.

4 Electrical details

4.1 USB

Parameter	Description	Minimum	Typical	Maximum	Units	Conditions
USB_VCC	Input Power Voltage*	4.25	5.0*	5.25	V	*Present when USB cable is attached and USB Host or Hub powered.
I _{cc}	USB current		30	50	mA	

Table 4.1 – USB Electrical Details

4.2 RS232

Parameter	Description	Minimum	Typical	Maximum	Units	Conditions
V _{trans}	Transmitter output voltage swing	± 5			V	RL = 3KΩ
V _{rec}	Receiver input voltage range	±2.4		±25	V	Input resistance = 3KΩ to 7KΩ
	ESD HBM		±15		KV	RS-232 Inputs and Outputs

Table 4.2 – RS232 Electrical Details

5 Mechanical Details

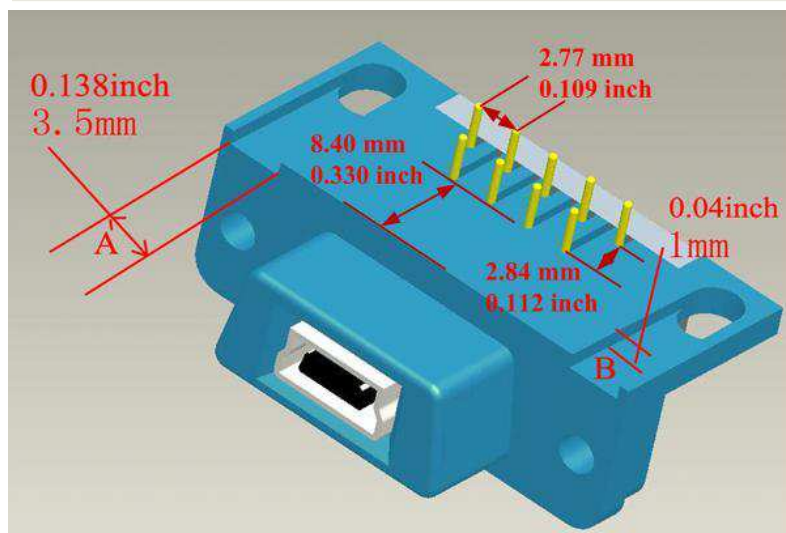
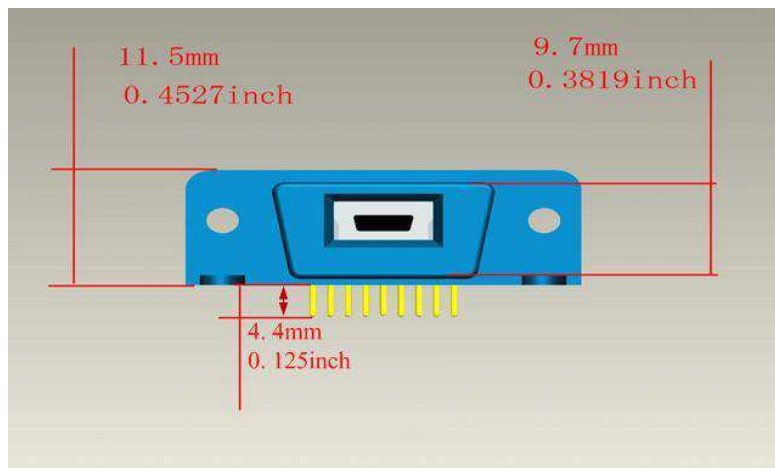
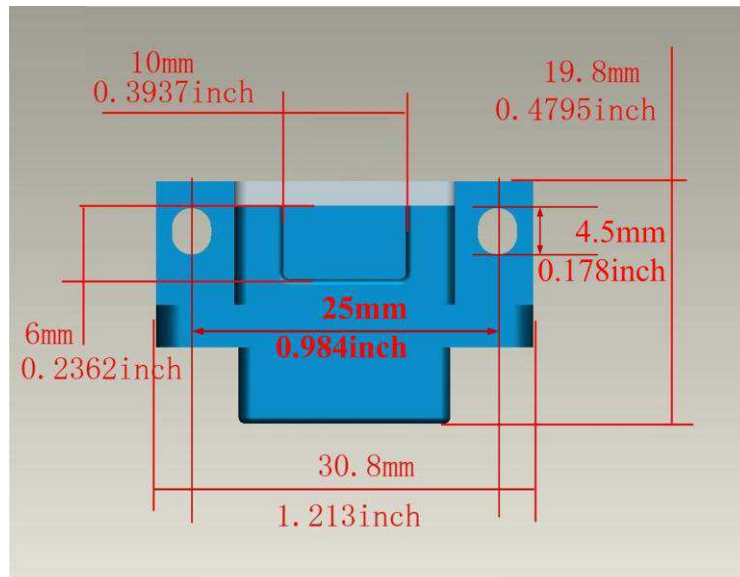

Figure 5.1 – DB9-USB-RS232-M/F module Dimensions

6 Physical Environment Details

6.1 Storage

Parameter	Description	Minimum	Typical	Maximum	Units	Conditions
T	Storage Temperature Range	TBD		TBD	°C	

Table 6.1 – Storage Temperature

6.2 Operating

Parameter	Description	Minimum	Typical	Maximum	Units	Conditions
T	Operating Temperature Range	-40		+85	°C	5% to 95% RH, non condensing

Table 6.2 – Operating Temperature

7 Environmental Approvals & Declarations

7.1 EMI Compatibility

FCC and CE

At the time of launch, the DB9-USB-RS232 is undergoing testing to be compliant with both FCC Part 15 Subpart B and European EMC Directive.



NOTE: This is a Class B product. In a domestic environment, this product may cause radio interference, in which case the user may be required to take adequate measures.



NOTE: This equipment is currently undergoing testing to comply with the limits for a Class B digital device, pursuant to Part 15 of the FCC Rules. These limits are designed to provide reasonable protection against harmful interference in a residential installation. This equipment generates uses and can radiate radio frequency energy and, if not installed and used in accordance with the instructions, may cause harmful interference to radio communications. However, there is no guarantee that interference will not occur in a particular installation. If this equipment does cause harmful interference to radio or television reception, which can be determined by turning the equipment off and on, the user is encouraged to try to correct the interference by one or more of the following measures:

- Reorient or relocate the receiving antenna.
- Increase the separation between the equipment and receiver.
- Connect the equipment into an outlet on a circuit different from that to which the receiver is connected.
- Consult the dealer or an experienced radio/TV technician for help.

7.2 Safety

The DB9-USB-RS232 is defined as Limited Power Supply (LPS) device, with operating voltages under 60VDC.

7.3 Environmental

The DB9-USB-RS232 is a lead-free device that complies with the following environmental directives: RoHS, WEEE, REACH, PFOS and DecaBDE.

7.4 Reliability

The DB9-USB-RS232 is designed as a robust USB-Serial module for use in many environments. There are no user-serviceable parts. Any failure will require a replacement of the unit.

7.4.1 MTF

The Mean Time To Failure is calculated at TBD hours.

7.5 Import / Export Information

Import / Export Information	
Country of Origin	China
Harmonized Code	7.5.1.1 8471.80.4000
Product Description	USB to RS232 Connector Adapter, Single Port
USA ECCN	EAR99 – No License Required

Table 7.1 – Import / Export Information

8 Troubleshooting

Ensure the latest device driver is in use. See www.ftdichip.com

If USB devices other than FTDI chips are installed in the system, then check with all manufacturers of these devices for the latest device drivers.

Section 3 details driver installation. If the user continues to have driver installation issues, then please refer to the FTDI installation guides <http://ftdichip.com/Documents/InstallGuides.htm> for additional details.

Common Windows Device Driver Troubles:

- **DEVICE TIMES OUT:** The default settings of the device driver assume typical data transfers of hundreds to thousands or more bytes at a given time. Some applications, such as a GPS device, only send data in short packets, often only a few bytes. If this is the case, it may be necessary to adjust the driver buffer size and/or latency timer to smaller values. These values can be adjusted through the Advanced driver options. The buffer size can be reduced to 64 bytes. The latency timer can be set as low as 2ms. A setting of 1ms will cause unnecessary USB traffic and could adversely affect data transmission. Advanced driver options are described in http://www.ftdichip.com/Documents/AppNotes/AN_107_AdvancedDriverOptions_AN_000073.pdf
- **ERRATIC MOUSE POINTER:** The device driver defaults to query an attached device to find out whether it is a mouse or modem, consistent with native COM port operation. Some RS232 peripherals constantly send short packets of data, causing the host system to “think” a mouse or modem has been attached. These short packets will interfere with normal mouse operation causing the pointer to jump around the screen. If this happens, disconnect the RS232 device and *uncheck the Serial Enumerator* option, also found on the Advanced driver options.
- **COM PORT IN USE:** Windows keeps track of all COM port assignments. If multiple FTDIChip products have been connected to a single system, the COM port number will increase, even if the other devices are not attached. If the higher COM port assignments are not acceptable for the application, known unused COM port numbers should be uninstalled according to the FTDI installation guide: <http://ftdichip.com/Documents/InstallGuides.htm>.

9 Contact Information

Head Office – Glasgow, UK

Future Technology Devices International Limited
Unit 1, 2 Seaward Place
Centurion Business Park
Glasgow, G41 1HH
United Kingdom
Tel: +44 (0) 141 429 2777
Fax: +44 (0) 141 429 2758

E-mail (Sales) sales1@ftdichip.com
E-mail (Support) support1@ftdichip.com
E-mail (General Enquiries) admin1@ftdichip.com
Web Site URL <http://www.ftdichip.com>
Web Shop URL <http://www.ftdichip.com>

Branch Office – Shanghai, China

Future Technology Devices International Limited (China)
Room 408, 317 Xianxia Road,
ChangNing District,
ShangHai, China

Tel: +86 (21) 62351596
Fax: +86(21) 62351595

E-Mail (Sales): cn.sales@ftdichip.com
E-Mail (Support): cn.support@ftdichip.com
E-Mail (General Enquiries): cn.admin1@ftdichip.com
Web Site URL: <http://www.ftdichip.com>

Branch Office – Taipei, Taiwan

Future Technology Devices International Limited (Taiwan)
2F, No 516, Sec. 1 NeiHu Road
Taipei 114
Taiwan, R.O.C.

Tel: +886 (0) 2 8791 3570
Fax: +886 (0) 2 8791 3576

E-mail (Sales) tw.sales1@ftdichip.com
E-mail (Support) tw.support1@ftdichip.com
E-mail (General Enquiries) tw.admin1@ftdichip.com
Web Site URL <http://www.ftdichip.com>

Branch Office – Hillsboro, Oregon, USA

Future Technology Devices International Limited (USA)
7235 NW Evergreen Parkway, Suite 600
Hillsboro, OR 97123-5803
USA

Tel: +1 (503) 547 0988
Fax: +1 (503) 547 0987

E-Mail (Sales) us.sales@ftdichip.com
E-Mail (Support) us.support@ftdichip.com
E-mail (General Enquiries) us.admin@ftdichip.com

Distributor and Sales Representatives

Please visit the Sales Network page of the FTDI Web site for the contact details of our distributor(s) and sales representative(s) in your country.

Vinculum is part of Future Technology Devices International Ltd. Neither the whole nor any part of the information contained in, or the product described in this manual, may be adapted or reproduced in any material or electronic form without the prior written consent of the copyright holder. This product and its documentation are supplied on an as-is basis and no warranty as to their suitability for any particular purpose is either made or implied. Future Technology Devices International Ltd will not accept any claim for damages howsoever arising as a result of use or failure of this product. Your statutory rights are not affected. This product or any variant of it is not intended for use in any medical appliance, device or system in which the failure of the product might reasonably be expected to result in personal injury. This document provides preliminary information that may be subject to change without notice. No freedom to use patents or other intellectual property rights is implied by the publication of this document. Future Technology Devices International Ltd, Unit 1, 2 Seaward Place, Centurion Business Park, Glasgow G41 1HH United Kingdom. Scotland Registered Number: SC136640

Appendix A – List of Figures and tables

List of Figures:

Figure 1.1 – DB9-USB-RS232	1
Figure 1.2 – DB9-USB-RS232 Block Diagram	2
Figure 2.1 – DB9-USB-RS232-M Pin-Out from a Top View through the module	7
Figure 2.2 – DB9-USB-RS232-M Connection illustration	7
Figure 2.3 – DB9-USB-RS232-F Pin-Out from a Top View through the module	9
Figure 2.4 – DB9-USB-RS232-F Connection illustration.....	9
Figure 3.1 – Hardware Ready	10
Figure 3.2 – Found New Hardware Wizard	10
Figure 3.3 – Automatic Install.....	11
Figure 3.4 – Complete Hardware Installation.....	11
Figure 3.5 – Hardware Ready	11
Figure 3.6 – Device Manager	12
Figure 3.7 – COM Port Assignment	12
Figure 3.8 – Access COM Port Properties.....	13
Figure 3.9 – Settings Tab	13
Figure 3.10 – Advanced Options	14
Figure 5.1 – DB9-USB-RS232-M/F module Dimensions.....	16

List of tables:

Table 1.1 – Performance Specifications	3
Table 1.2 – Ordering Information	3
Table 2.1 – USB “mini-B” Receptacle Pin-Out.....	5
Table 2.2 – A Male RS232 DB9 footprint Pin-Out	6
Table 2.3 – A Female RS232 DB9 footprint Pin-Out	8
Table 4.1 – USB Electrical Details	15
Table 4.2 – RS232 Electrical Details	15
Table 6.1 – Storage Temperature	17
Table 6.2 – Operating Temperature	17
Table 7.1 – Import / Export Information	19
Table B.1 – RS232 DTE to DCE connection with straight-through wiring	24
Table B.2 – RS232 DTE to DTE connection with null-modem wiring	25

Appendix B – DCE and DTE Wire Configurations

This section is included for reference when designing a PCB for a DB9-USB-RS232 module; here some of the subtle details of DTE and DCE wire configurations will be outlined.

B.1 Wire Configuration for the Male and Female Modules

When designing a PCB for the DB9-USB-RS232 module consideration should be given to Data Terminal Equipment (DTE) and Data Communication Equipment (DCE) connection standards. The DB9-USB-RS232 modules are designed as a DTE device. When a DTE device is being connected to the DB9-USB-RS232 a “null-modem” wiring is used, when the DB9-USB-RS232 is connected to a DCE a “straight through” wiring is used. The expressions “null-modem” and “straight through” are explained in the next subsection.

The male DB9-USB-RS232-M module is designed to replace a male DB9 connector of a DTE device (according to TIA standards Male DB9 connectors are to be used only with wiring DTE to UART). The female DB9-USB-RS232-F module is designed to replace a female DB9 connector of a DCE device (according to TIA standards Female DB9 connectors are to be used only with wiring DCE to UART).

B.1.1 RS232 Wiring

RS232 cables have followed a standard 9-pin configuration on a D-sub connector since the mid 1980s. The DB9-USB-RS232-M modules are DTE devices. To connect a DB9-USB-RS232 module to a DCE device, a “straight-through” wiring scheme, as described in Table B.1, needs to be used.

DTE Pin Number	Signal Name	DCE Pin Number
1	DCD = Data Carrier Detect	1
2	RXD = Receive Data	2
3	TXD = Transmit Data	3
4	DTR = Data Terminal Ready	4
5	GND = RS232 signal ground	5
6	DSR = Data Set Ready	6
7	RTS = Request To Send	7
8	CTS = Clear To Send	8
9	RI = Ring Indicator	9

Table B.1 – RS232 DTE to DCE connection with straight-through wiring

To connect a DB9-USB-RS232 module to a DCE device, a “null-modem” wiring scheme, as described in Table B.2 needs to be used.

DTE Pin Number	Signal Name	DTE Pin Number
2	RXD = Receive Data	3
3	TXD = Transmit Data	2
4	DTR = Data Terminal Ready	6
5	GND = RS232 signal ground	5
6	DSR = Data Set Ready	4
7	RTS = Request To Send	8
8	CTS = Clear To Send	7

Table B.2 – RS232 DTE to DTE connection with null-modem wiring

Note that the DB9-USB-RS232-M is not a DB9-USB-RS232-F with its pins latterly inverted; there is a “null-modem” wiring configuration present in the DB9-USB-RS232-M module. This means that a DB9-USB-RS232-M is not pin compatible with a female footprint when placed on the underneath side of the board.

Appendix C – Revision History

Version Draft	First Draft	October 2009
Version 1.0	First release	18 th November 2009
Version 1.1	Updated part numbers	19 th February 2010
Version 1.2	Added Figures 2.2 and 2.4. Updated tables 2.2 and 2.3 Added note 1 to Table 2.2	1 st June 2010