



HESTORE.HU

elektronikai alkatrész áruház

EN: This Datasheet is presented by the manufacturer.

Please visit our website for pricing and availability at www.hestore.hu.

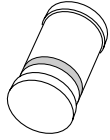

BAV102; BAV103

Single general-purpose switching diodes

Rev. 03 — 16 August 2007

Product data sheet

1. Product profile

1.1 General description

Single general-purpose switching diodes, fabricated in planar technology, and encapsulated in small hermetically sealed glass SOD80C Surface-Mounted Device (SMD) packages.

Table 1. Product overview

Type number	Package		Configuration
	NXP	JEITA	
BAV102	SOD80C	-	single
BAV103			

1.2 Features

- High switching speed: $t_{rr} \leq 50$ ns
- Low leakage current
- Low capacitance: $C_d \leq 5$ pF
- Small hermetically sealed glass SMD package

1.3 Applications

- High-speed switching
- General-purpose switching
- Voltage clamping
- Reverse polarity protection

1.4 Quick reference data

Table 2. Quick reference data

Symbol	Parameter	Conditions	Min	Typ	Max	Unit
I_F	forward current	[1][2]	-	-	250	mA
V_R	reverse voltage					
	BAV102		-	-	150	V
	BAV103		-	-	200	V
t_{rr}	reverse recovery time	[3]	-	-	50	ns

[1] Pulse test: $t_p \leq 300$ μ s; $\delta \leq 0.02$.

[2] Device mounted on an FR4 Printed-Circuit Board (PCB), single-sided copper, tin-plated and standard footprint.

[3] When switched from $I_F = 30$ mA to $I_R = 30$ mA; $R_L = 100$ Ω ; measured at $I_R = 3$ mA.

2. Pinning information

Table 3. Pinning

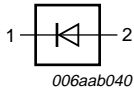
Pin	Description	Simplified outline	Symbol
1	cathode ^[1]		
2	anode		

[1] The marking band indicates the cathode.

3. Ordering information

Table 4. Ordering information

Type number	Package		Version
	Name	Description	
BAV102	-	hermetically sealed glass surface-mounted package;	SOD80C
BAV103	-	2 connectors	

4. Marking

Table 5. Marking codes

Type number	Marking code ^[1]
BAV102	marking band
BAV103	

[1] green: made in Philippines

5. Limiting values

Table 6. Limiting values

In accordance with the Absolute Maximum Rating System (IEC 60134).

Symbol	Parameter	Conditions	Min	Max	Unit
V_{RRM}	repetitive peak reverse voltage				
		BAV102	-	200	V
		BAV103	-	250	V
V_R	reverse voltage				
		BAV102	-	150	V
		BAV103	-	200	V
I_F	forward current	^{[1][2]}	-	250	mA
I_{FRM}	repetitive peak forward current		-	625	mA

Table 6. Limiting values ...continued

In accordance with the Absolute Maximum Rating System (IEC 60134).

Symbol	Parameter	Conditions	Min	Max	Unit
I_{FSM}	non-repetitive peak forward current	square wave	[3]		
		$t_p = 1 \mu s$	-	9	A
		$t_p = 100 \mu s$	-	3	A
		$t_p = 1 s$	-	1	A
P_{tot}	total power dissipation	$T_{amb} \leq 25 \text{ }^\circ\text{C}$	[2]	400	mW
T_j	junction temperature		-	175	$^\circ\text{C}$
T_{amb}	ambient temperature		-65	+175	$^\circ\text{C}$
T_{stg}	storage temperature		-65	+175	$^\circ\text{C}$

[1] Pulse test: $t_p \leq 300 \mu s$; $\delta \leq 0.02$.

[2] Device mounted on an FR4 PCB, single-sided copper, tin-plated and standard footprint.

[3] $T_j = 25 \text{ }^\circ\text{C}$ prior to surge.

6. Thermal characteristics

Table 7. Thermal characteristics

Symbol	Parameter	Conditions	Min	Typ	Max	Unit
$R_{th(j-a)}$	thermal resistance from junction to ambient	in free air	[1]	-	375	K/W
$R_{th(j-t)}$	thermal resistance from junction to tie-point		-	-	300	K/W

[1] Device mounted on an FR4 PCB, single-sided copper, tin-plated and standard footprint.

7. Characteristics

Table 8. Characteristics $T_{amb} = 25 \text{ }^\circ\text{C}$ unless otherwise specified.

Symbol	Parameter	Conditions	Min	Typ	Max	Unit	
V_F	forward voltage		[1]				
		$I_F = 100 \text{ mA}$	-	-	1.0	V	
		$I_F = 200 \text{ mA}$	-	-	1.25	V	
I_R	reverse current	BAV102	$V_R = 150 \text{ V}$	-	-	100	nA
			$V_R = 150 \text{ V}; T_j = 150 \text{ }^\circ\text{C}$	-	-	100	μA
		BAV103	$V_R = 200 \text{ V}$	-	-	100	nA
			$V_R = 200 \text{ V}; T_j = 150 \text{ }^\circ\text{C}$	-	-	100	μA
		C_d	diode capacitance	$f = 1 \text{ MHz}; V_R = 0 \text{ V}$	-	-	5
t_{rr}	reverse recovery time		[2]	-	50	ns	

[1] Pulse test: $t_p \leq 300 \mu s$; $\delta \leq 0.02$.[2] When switched from $I_F = 30 \text{ mA}$ to $I_R = 30 \text{ mA}$; $R_L = 100 \Omega$; measured at $I_R = 3 \text{ mA}$.

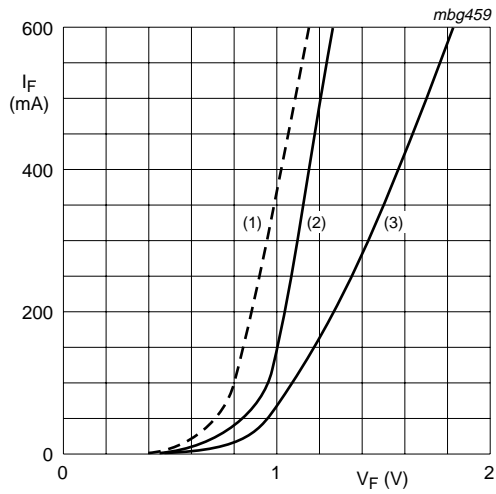

- (1) $T_{amb} = 150\text{ °C}$; typical values
- (2) $T_{amb} = 25\text{ °C}$; typical values
- (3) $T_{amb} = 25\text{ °C}$; maximum values

Fig 1. Forward current as a function of forward voltage

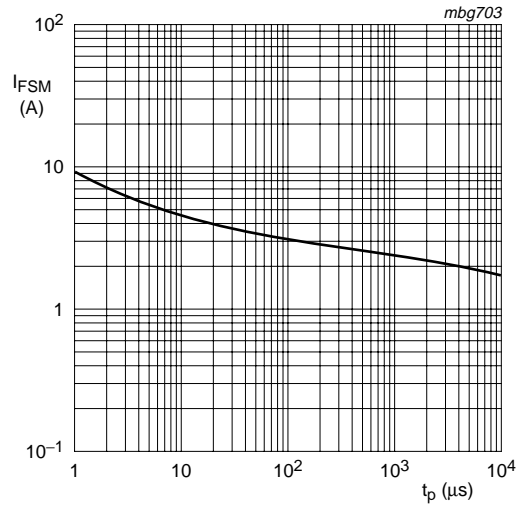

Based on square wave currents.
 $T_j = 25\text{ °C}$; prior to surge

Fig 2. Non-repetitive peak forward current as a function of pulse duration; maximum values

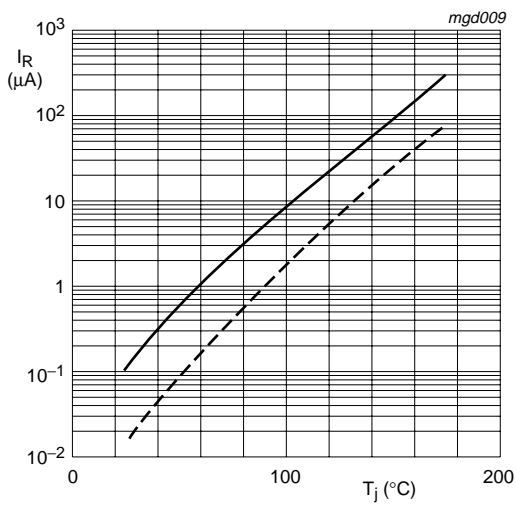

$V_R = V_{Rmax}$
 Solid line: maximum values
 Dotted line: typical values

Fig 3. Reverse current as a function of junction temperature

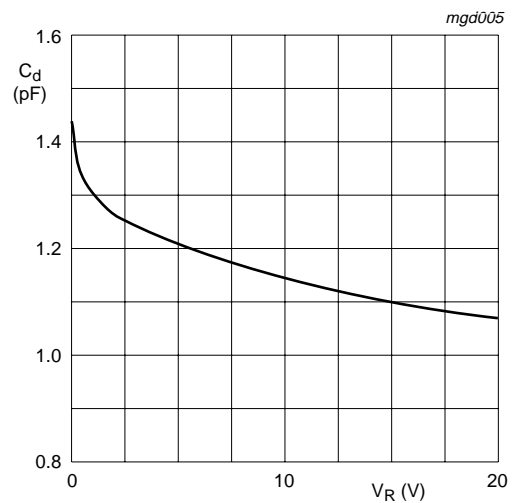

$f = 1\text{ MHz}$; $T_{amb} = 25\text{ °C}$

Fig 4. Diode capacitance as a function of reverse voltage; typical values

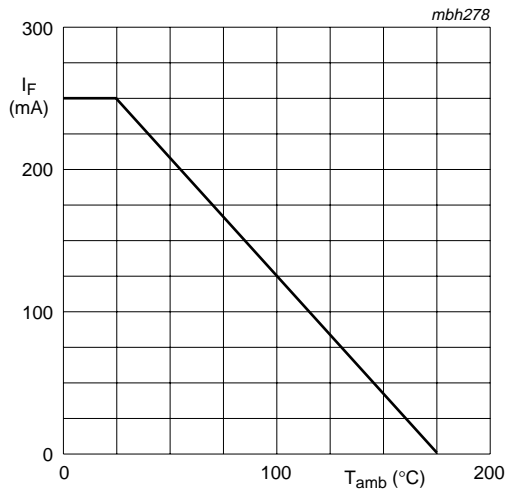

FR4 PCB, standard footprint

Fig 5. Forward current as a function of ambient temperature; derating curve

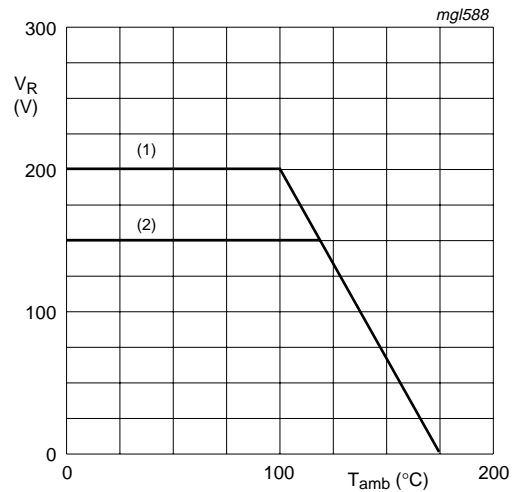

FR4 PCB, standard footprint

- (1) BAV103
- (2) BAV102

Fig 6. Reverse voltage as a function of ambient temperature; derating curve

8. Test information

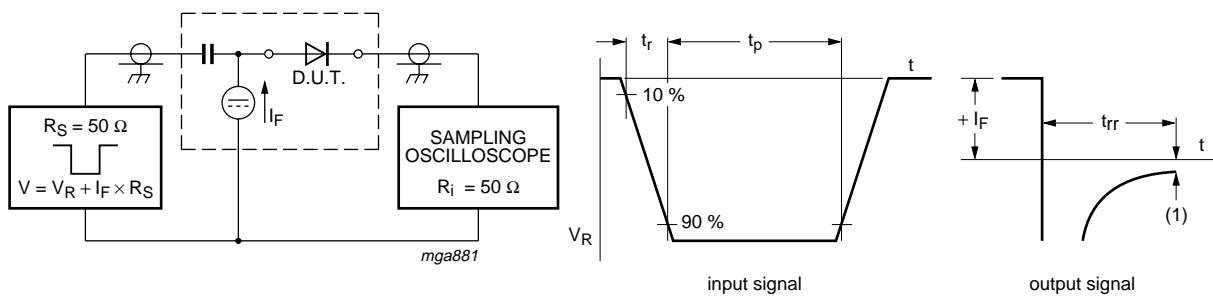

- (1) $I_R = 1 \text{ mA}$

Fig 7. Reverse recovery time test circuit and waveforms

9. Package outline

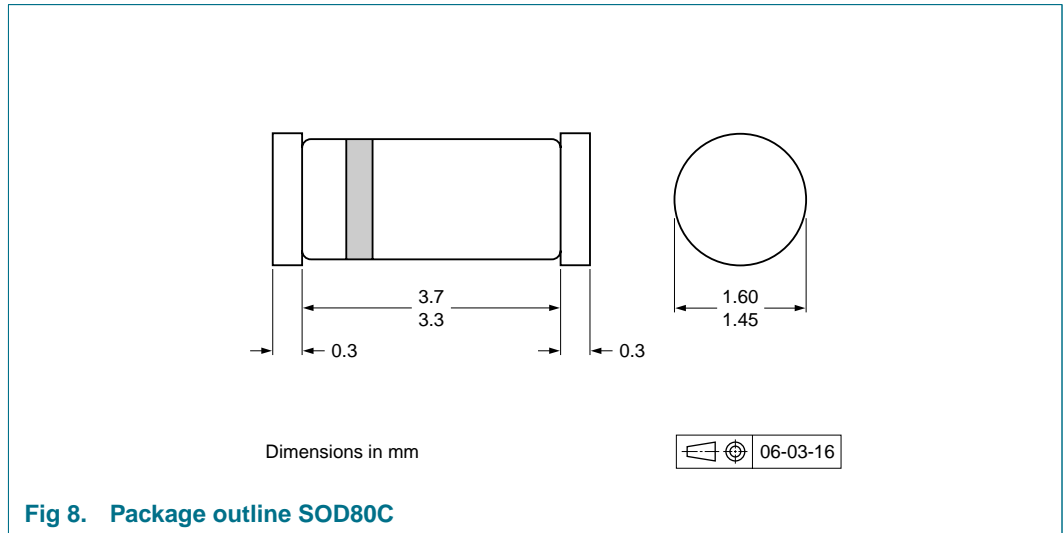

10. Packing information

Table 9. Packing methods

The indicated -xxx are the last three digits of the 12NC ordering code.^[1]

Type number	Package	Description	Packing quantity	
			2500	10000
BAV102	SOD80C	4 mm pitch, 8 mm tape and reel	-115	-135
BAV103				

[1] For further information and the availability of packing methods, see [Section 14](#).

11. Soldering

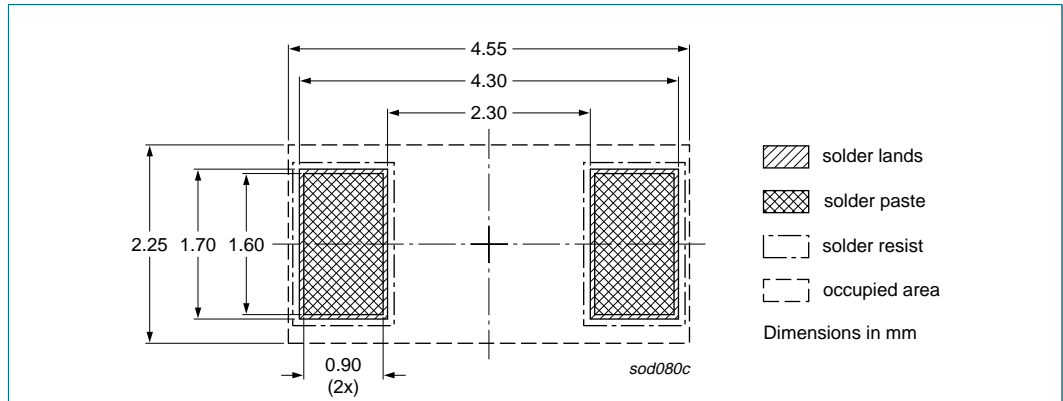

Fig 9. Reflow soldering footprint SOD80C

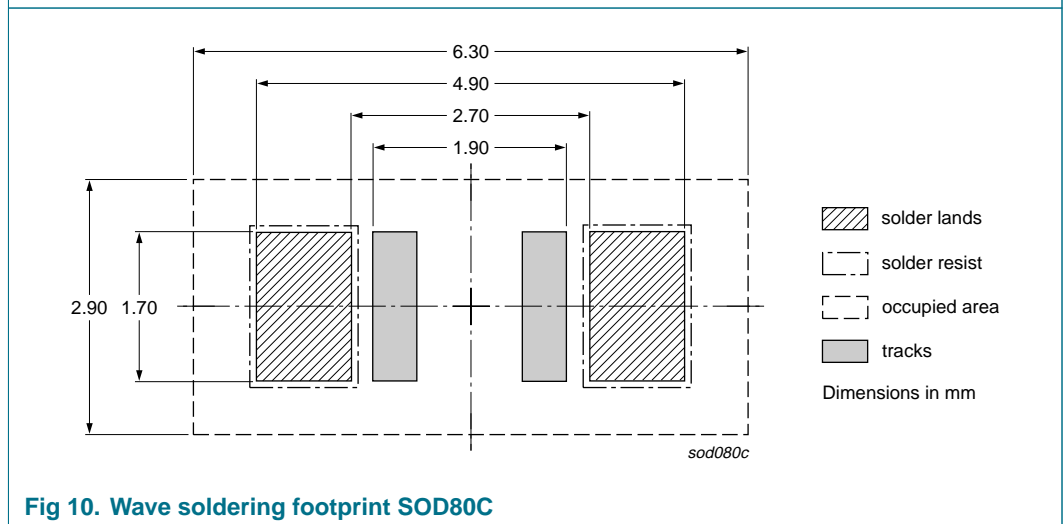

Fig 10. Wave soldering footprint SOD80C

12. Revision history

Table 10. Revision history

Document ID	Release date	Data sheet status	Change notice	Supersedes
BAV102_BAV103_3	20070816	Product data sheet	-	BAV100_2
Modifications:	<ul style="list-style-type: none"> • The format of this data sheet has been redesigned to comply with the new identity guidelines of NXP Semiconductors. • Legal texts have been adapted to the new company name where appropriate. • Type numbers BAV100 and BAV101 have been removed • Section 1.1 “General description”: amended • Table 1 “Product overview”: added • Table 2 “Quick reference data”: added • Section 3 “Ordering information”: added • Figure 7: figure title amended • Figure 8: superseded by minimized package outline drawing • Section 10 “Packing information”: added • Section 11 “Soldering”: added • Section 13 “Legal information”: updated 			
BAV100_2	19960917	Product specification	-	BAV100_1
BAV100_1	19960423	Product specification	-	-

13. Legal information

13.1 Data sheet status

Document status ^{[1][2]}	Product status ^[3]	Definition
Objective [short] data sheet	Development	This document contains data from the objective specification for product development.
Preliminary [short] data sheet	Qualification	This document contains data from the preliminary specification.
Product [short] data sheet	Production	This document contains the product specification.

[1] Please consult the most recently issued document before initiating or completing a design.

[2] The term 'short data sheet' is explained in section "Definitions".

[3] The product status of device(s) described in this document may have changed since this document was published and may differ in case of multiple devices. The latest product status information is available on the Internet at URL <http://www.nxp.com>.

13.2 Definitions

Draft — The document is a draft version only. The content is still under internal review and subject to formal approval, which may result in modifications or additions. NXP Semiconductors does not give any representations or warranties as to the accuracy or completeness of information included herein and shall have no liability for the consequences of use of such information.

Short data sheet — A short data sheet is an extract from a full data sheet with the same product type number(s) and title. A short data sheet is intended for quick reference only and should not be relied upon to contain detailed and full information. For detailed and full information see the relevant full data sheet, which is available on request via the local NXP Semiconductors sales office. In case of any inconsistency or conflict with the short data sheet, the full data sheet shall prevail.

13.3 Disclaimers

General — Information in this document is believed to be accurate and reliable. However, NXP Semiconductors does not give any representations or warranties, expressed or implied, as to the accuracy or completeness of such information and shall have no liability for the consequences of use of such information.

Right to make changes — NXP Semiconductors reserves the right to make changes to information published in this document, including without limitation specifications and product descriptions, at any time and without notice. This document supersedes and replaces all information supplied prior to the publication hereof.

Suitability for use — NXP Semiconductors products are not designed, authorized or warranted to be suitable for use in medical, military, aircraft, space or life support equipment, nor in applications where failure or

malfunction of a NXP Semiconductors product can reasonably be expected to result in personal injury, death or severe property or environmental damage. NXP Semiconductors accepts no liability for inclusion and/or use of NXP Semiconductors products in such equipment or applications and therefore such inclusion and/or use is at the customer's own risk.

Applications — Applications that are described herein for any of these products are for illustrative purposes only. NXP Semiconductors makes no representation or warranty that such applications will be suitable for the specified use without further testing or modification.

Limiting values — Stress above one or more limiting values (as defined in the Absolute Maximum Ratings System of IEC 60134) may cause permanent damage to the device. Limiting values are stress ratings only and operation of the device at these or any other conditions above those given in the Characteristics sections of this document is not implied. Exposure to limiting values for extended periods may affect device reliability.

Terms and conditions of sale — NXP Semiconductors products are sold subject to the general terms and conditions of commercial sale, as published at <http://www.nxp.com/profile/terms>, including those pertaining to warranty, intellectual property rights infringement and limitation of liability, unless explicitly otherwise agreed to in writing by NXP Semiconductors. In case of any inconsistency or conflict between information in this document and such terms and conditions, the latter will prevail.

No offer to sell or license — Nothing in this document may be interpreted or construed as an offer to sell products that is open for acceptance or the grant, conveyance or implication of any license under any copyrights, patents or other industrial or intellectual property rights.

13.4 Trademarks

Notice: All referenced brands, product names, service names and trademarks are the property of their respective owners.

14. Contact information

For additional information, please visit: <http://www.nxp.com>

For sales office addresses, send an email to: salesaddresses@nxp.com

15. Contents

1 Product profile 1

1.1 General description 1

1.2 Features 1

1.3 Applications 1

1.4 Quick reference data 1

2 Pinning information 2

3 Ordering information 2

4 Marking 2

5 Limiting values 2

6 Thermal characteristics 3

7 Characteristics 3

8 Test information 5

9 Package outline 6

10 Packing information 6

11 Soldering 7

12 Revision history 8

13 Legal information 9

13.1 Data sheet status 9

13.2 Definitions 9

13.3 Disclaimers 9

13.4 Trademarks 9

14 Contact information 9

15 Contents 10

Please be aware that important notices concerning this document and the product(s) described herein, have been included in section 'Legal information'.



© NXP B.V. 2007.

All rights reserved.

For more information, please visit: <http://www.nxp.com>

For sales office addresses, please send an email to: salesaddresses@nxp.com

Date of release: 16 August 2007

Document identifier: BAV102_BAV103_3