



**HESTORE.HU**

elektronikai alkatrész áruház

**EN:** This Datasheet is presented by the manufacturer.

Please visit our website for pricing and availability at [www.hestore.hu](http://www.hestore.hu).

# Smart High-Side Power Switch for Industrial Applications

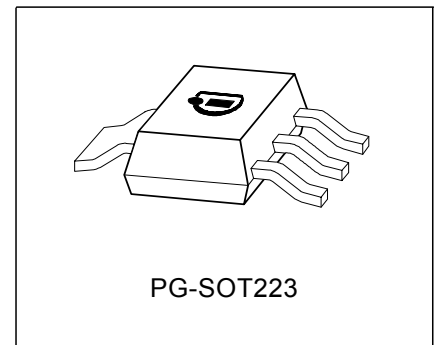
## 1 Channel: 1 x 200mΩ

### Features

- Short circuit protection
- Current limitation
- Overload protection
- Overvoltage protection (including load dump)
- Undervoltage shutdown with auto-restart and hysteresis
- Switching inductive loads
- Clamp of negative voltage at output with inductive loads
- CMOS compatible input
- Thermal shutdown with restart
- ESD - Protection
- Loss of GND and loss of  $V_{bb}$  protection
- Very low standby current
- Reverse battery protection with external resistor
- Improved electromagnetic compatibility (EMC)

### Product Summary

Overvoltage protection	$V_{bb(AZ)}$	47	V
Operating voltage	$V_{bb(on)}$	12...45	V
On-state resistance	$R_{ON}$	200	mΩ
Operating temperature	$T_a$	-30...+85	°C



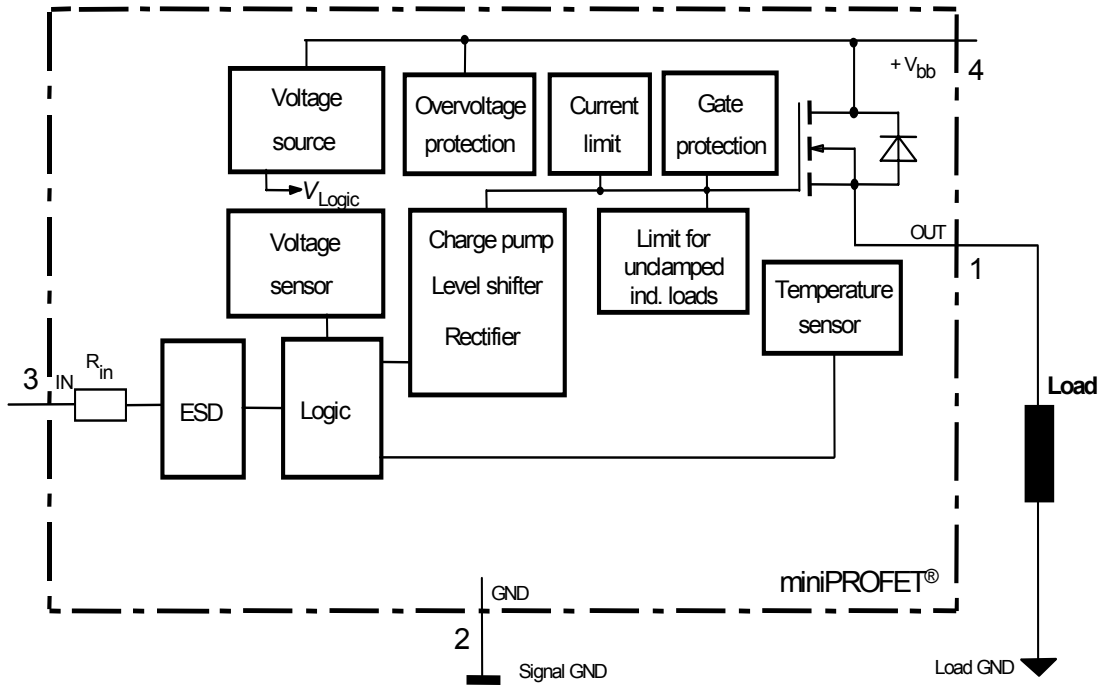
### Application

- All types of resistive, inductive and capacitive loads
- $\mu$ C compatible power switch for 12 V and 24 V DC industrial applications
- Replaces electromechanical relays and discrete circuits

### General Description

N channel vertical power FET with charge pump, ground referenced CMOS compatible input, monolithically integrated in Smart SIPMOS® technology. Providing embedded protective functions.

### Block Diagram



Pin	Symbol	Function
1	OUT	Output to the load
2	GND	Logic ground
3	IN	Input, activates the power switch in case of logic high signal
4	Vbb	Positive power supply voltage

**Maximum Ratings**

Parameter	Symbol	Value	Unit
at $T_j = 25^\circ\text{C}$ , unless otherwise specified			
Supply voltage	$V_{bb}$	-0,3 <sup>1)</sup> ...48	V
Continuous input voltage <sup>2)</sup>	$V_{IN}$	-10... $V_{bb}$	
Load current (Short - circuit current, see page 5)	$I_L$	self limited	A
Current through input pin (DC)	$I_{IN}$	$\pm 5$	mA
Reverse current through GND-pin <sup>3)</sup>	$-I_{GND}$	-0.5	A
Junction temperature	$T_j$	internal limited	$^\circ\text{C}$
Operating temperature	$T_a$	-30...+85	$^\circ\text{C}$
Storage temperature	$T_{stg}$	-40 ... +105	$^\circ\text{C}$
Power dissipation <sup>4)</sup>	$P_{tot}$	1.4	W
Inductive load switch-off energy dissipation <sup>4)5)</sup> single pulse $T_j = 125^\circ\text{C}$ , $I_L = 0.5\text{ A}$	$E_{AS}$	0.7	J
Load dump protection <sup>5)</sup> $V_{LoadDump}^{6)} = V_A + V_S$ $R_I = 2\Omega$ , $t_d = 400\text{ms}$ , $V_{IN} = \text{low or high}$ , $V_A = 13,5\text{V}$ $R_L = 47\ \Omega$	$V_{Loaddump}$	83	V
<b>Electrostatic discharge voltage (Human Body Model)</b> according to ANSI EOS/ESD - S5.1 - 1993 ESD STM5.1 - 1998	$V_{ESD}$		kV
Input pin		$\pm 1$	
All other pins		$\pm 5$	

<sup>1</sup>defined by  $P_{tot}$

<sup>2</sup>At  $V_{IN} > V_{bb}$ , the input current is not allowed to exceed  $\pm 5\text{ mA}$ .

<sup>3</sup>defined by  $P_{tot}$

<sup>4</sup>Device on 50mm\*50mm\*1.5mm epoxy PCB FR4 with 6 cm<sup>2</sup> (one layer, 70 $\mu\text{m}$  thick) copper area for  $V_{bb}$  connection. PCB is vertical without blown air.

<sup>5</sup>not subject to production test, specified by design

<sup>6</sup> $V_{Loaddump}$  is setup without the DUT connected to the generator per ISO 7637-1 and DIN 40839 .

Supply voltages higher than  $V_{bb(AZ)}$  require an external current limit for the GND pin, e.g. with a 150 $\Omega$  resistor in GND connection. A resistor for the protection of the input is integrated.

**Electrical Characteristics**

Parameter at $T_j = -40 \dots 125 \text{ }^\circ\text{C}$ , $V_{bb} = 15 \dots 30 \text{ V}$ unless otherwise specified	Symbol	Values			Unit
		min.	typ.	max.	

**Thermal Characteristics**

Thermal resistance @ min. footprint	$R_{th(JA)}$	-	-	125	K/W
Thermal resistance @ 6 cm <sup>2</sup> cooling area <sup>1)</sup>	$R_{th(JA)}$	-	-	70	
Thermal resistance, junction - soldering point	$R_{th(JS)}$	-	-	7	K/W

**Load Switching Capabilities and Characteristics**

On-state resistance $T_j = 25 \text{ }^\circ\text{C}$ , $I_L = 0.5 \text{ A}$ $T_j = 125 \text{ }^\circ\text{C}$	$R_{ON}$	-	150	200	mΩ
		-	270	320	
Nominal load current <sup>2)</sup> Device on PCB <sup>1)</sup>	$I_{L(nom)}$	0.7	-	-	A
Turn-on time to 90% $V_{OUT}$ $R_L = 47 \text{ } \Omega$ , $V_{IN} = 0 \text{ to } 10 \text{ V}$	$t_{on}$	-	50	100	μs
Turn-off time to 10% $V_{OUT}$ $R_L = 47 \text{ } \Omega$ , $V_{IN} = 10 \text{ to } 0 \text{ V}$	$t_{off}$	-	75	150	
Slew rate on 10 to 30% $V_{OUT}$ , $R_L = 47 \text{ } \Omega$ , $V_{bb} = 15 \text{ V}$	$dV/dt_{on}$	-	1	2	V/μs
Slew rate off 70 to 40% $V_{OUT}$ , $R_L = 47 \text{ } \Omega$ , $V_{bb} = 15 \text{ V}$	$-dV/dt_{off}$	-	1	2	

<sup>1</sup>Device on 50mm\*50mm\*1.5mm epoxy PCB FR4 with 6 cm<sup>2</sup> (one layer, 70μm thick) copper area for  $V_{bb}$  connection. PCB is vertical without blown air.

<sup>2</sup>Nominal load current is limited by the current limitation ( see page 5 )

**Electrical Characteristics**

Parameter	Symbol	Values			Unit
		min.	typ.	max.	
at $T_j = -40...125\text{ °C}$ , $V_{bb} = 15...30\text{ V}$ unless otherwise specified					

**Operating Parameters**

Operating voltage	$V_{bb(on)}$	12	-	45	V
Undervoltage shutdown	$V_{bb(under)}$	7	-	10.5	
Undervoltage restart	$V_{bb(u\ rst)}$	-	-	11	
Undervoltage hysteresis $\Delta V_{bb(under)} = V_{bb(u\ rst)} - V_{bb(under)}$	$\Delta V_{bb(under)}$	-	0.5	-	
Standby current $T_j = -40...85\text{ °C}$ , $V_{IN} \leq 1,2\text{ V}$ $T_j = 125\text{ °C}^1)$	$I_{bb(off)}$	-	10	25	$\mu\text{A}$
		-	-	50	
Operating current	$I_{GND}$	-	1	1.6	mA
Leakage output current (included in $I_{bb(off)}$ ) $V_{IN} \leq 1,2\text{ V}$	$I_{L(off)}$	-	3.5	10	$\mu\text{A}$

**Protection Functions<sup>2)</sup>**

Initial peak short circuit current limit $T_j = -40\text{ °C}$ , $V_{bb} = 20\text{ V}$ , $t_m = 150\text{ }\mu\text{s}$ $T_j = 25\text{ °C}$ $T_j = 125\text{ °C}$	$I_{L(SCp)}$	-	-	2.1	A
		-	1.4	-	
		0.7	-	-	
Repetitive short circuit current limit $T_j = T_{jt}$ (see timing diagrams)	$I_{L(SCr)}$	-	1.1	-	
Output clamp (inductive load switch off) at $V_{OUT} = V_{bb} - V_{ON(CL)}$ , $I_{bb} = 4\text{ mA}$	$V_{ON(CL)}$	62	68	-	V
Overvoltage protection <sup>3)</sup> $I_{bb} = 4\text{ mA}$	$V_{bb(AZ)}$	47	-	-	
Thermal overload trip temperature <sup>4)</sup>	$T_{jt}$	135	-	-	$^{\circ}\text{C}$
Thermal hysteresis	$\Delta T_{jt}$	-	10	-	K

<sup>1</sup>higher current due temperature sensor

<sup>2</sup>Integrated protection functions are designed to prevent IC destruction under fault conditions described in the data sheet. Fault conditions are considered as "outside" normal operating range. Protection functions are not designed for continuous repetitive operation.

<sup>3</sup>see also  $V_{ON(CL)}$  in circuit diagram

<sup>4</sup> higher operating temperature at normal function available

**Electrical Characteristics**

Parameter at $T_j = -40...125\text{ °C}$ , $V_{bb} = 15...30\text{ V}$ unless otherwise specified	Symbol	Values			Unit
		min.	typ.	max.	

**Input**

Continuous input voltage <sup>1)</sup>	$V_{IN}$	-10 <sup>2)</sup>	-	$V_{bb}$	V
Input turn-on threshold voltage	$V_{IN(T+)}$	-	-	3.0	
Input turn-off threshold voltage	$V_{IN(T-)}$	1.82	-	-	
Input threshold hysteresis	$\Delta V_{IN(T)}$	-	0.2	-	
Off state input current $V_{IN} \leq 1,8\text{ V}$	$I_{IN(off)}$	20	-	-	$\mu\text{A}$
On state input current	$I_{IN(on)}$	-	-	110	
Input delay time at switch on $V_{bb}$	$t_{d(V_{bbon})}$	150	340	-	$\mu\text{s}$
Input resistance (see page 8)	$R_I$	1.5	3	5	$\text{k}\Omega$

**Reverse Battery**

Reverse battery voltage <sup>3)2)</sup> $R_{GND} = 0\ \Omega$ $R_{GND} = 150\ \Omega$	$-V_{bb}$	-	-	0.3 45	V
Continuous reverse drain current <sup>2)</sup> $T_j = 25\text{ °C}$	$I_S$	-	-	1	A
Drain-source diode voltage ( $V_{OUT} > V_{bb}$ ) $I_F = 1\text{ A}$	$-V_{ON}$	-	0.6	1.2	V

<sup>1)</sup>At  $V_{IN} > V_{bb}$ , the input current is not allowed to exceed  $\pm 5\text{ mA}$ .

<sup>2)</sup>not subject to production test, guaranteed by design

<sup>3)</sup>defined by  $P_{tot}$

**EMC-Characteristics**

All EMC-Characteristics are based on limited number of sampels and no part of production test.

**Test Conditions:**

If not other specified the test circuitry is the minimal functional configuration without any external components for protection or filtering.

Supply voltage:  $V_{bb} = 13.5V$                       Temperature:  $T_a = 23 \pm 5^\circ C$  ;  
 Load:  $R_L = 220\Omega$   
 Operation mode: PWM                                  Frequency: 100Hz / Duty Cycle: 50%  
                                 DC On/Off  
 DUT-Specific.:  $R_{GND}$

**Fast electrical transients**

Acc. ISO 7637

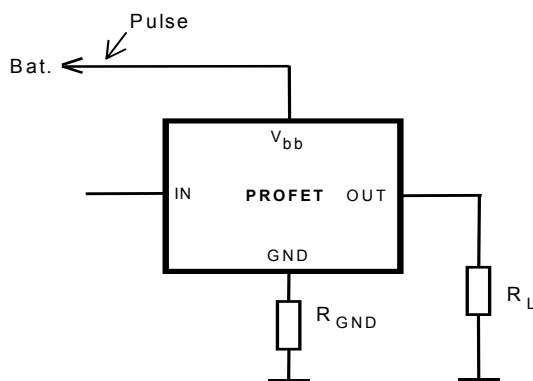
Test Pulse	Test Level	Test Results		Pulse Cycle Time and Generator Impedance
		On	Off	
1	-200 V	C	C	500ms ; 10Ω
2	+200 V	C	C	500ms ; 10Ω
3a	-200 V	C	C	100ms ; 50Ω
3b	+ 200 V	C	C	100ms ; 50Ω
4 <sup>1)</sup>	-7 V	C	C	0,01Ω
5	175 V	E (70V)	E (70V)	400ms ; 2Ω

The test pulses are applied at  $V_{bb}$

**Definition of functional status**

Class	Content
C	All functions of the device are performed as designed after exposure to disturbance.
E	One or more function of a device does not perform as designed after exposure and can not be returned to proper operation without repairing or replacing the device. The value after the character shows the limit.

**Test circuit:**



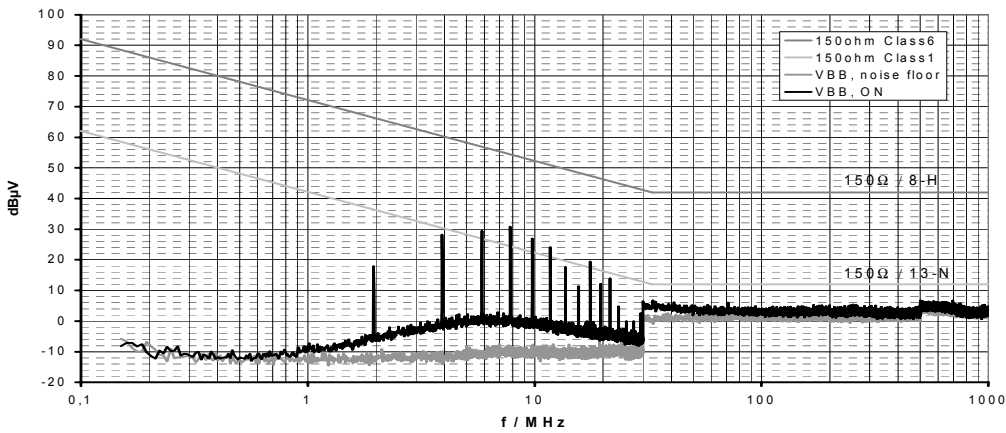
<sup>1</sup>Supply voltage  $V_{bb} = 12 V$  instead of 13,5 V.



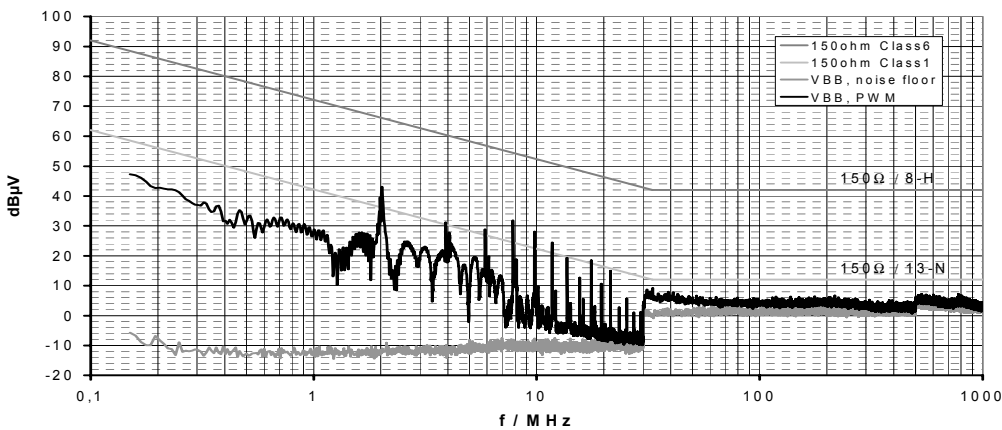
### Conducted Emission

Acc. IEC 61967-4 (1Ω / 150Ω method)

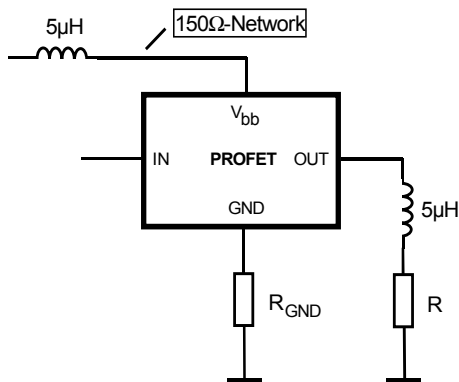
#### Typ. $V_{bb}$ -Pin Emission at DC-On with 150Ω-matching network



#### Typ. $V_{bb}$ -Pin Emission at PWM-Mode with 150Ω-matching network



#### Test circuit:



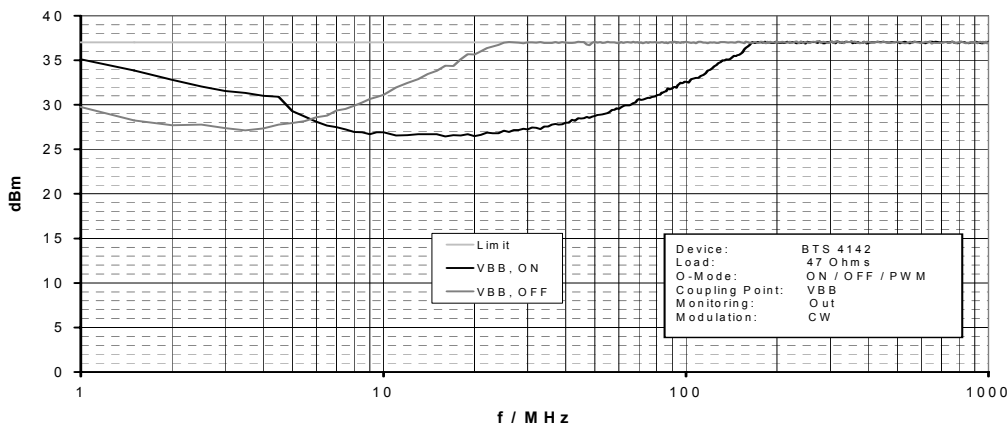
For defined decoupling and high reproducibility a defined choke (5μH at 1 MHz) is inserted between supply and  $V_{bb}$ -pin.

### Conducted Susceptibility

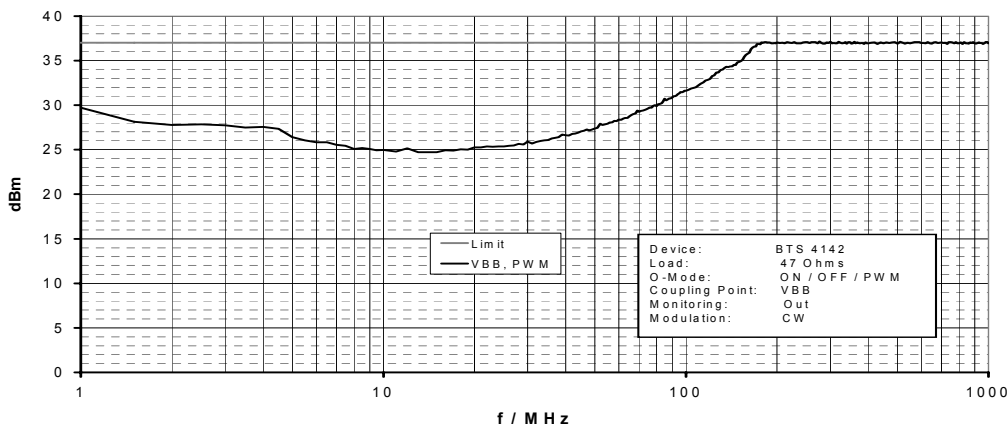
Acc. 47A/658/CD IEC 62132-4 (Direct Power Injection)

**Direct Power Injection:** Forward Power CW  
**Failure criteria:** Amplitude and frequency deviation max. 10% at Out

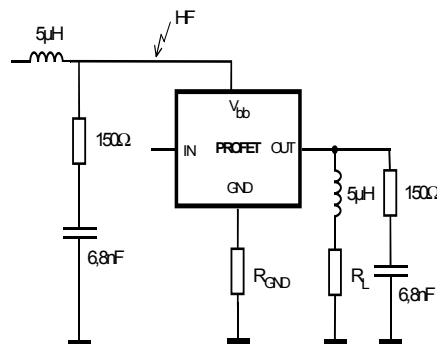
#### Typ. $V_{bb}$ -Pin Susceptibility at DC-On/Off



#### Typ. $V_{bb}$ -Pin Susceptibility at PWM-Mode

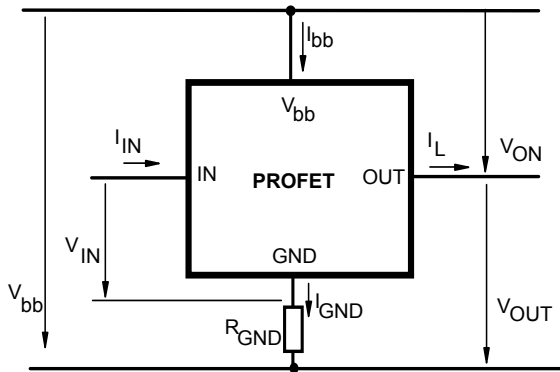


#### Test circuit:

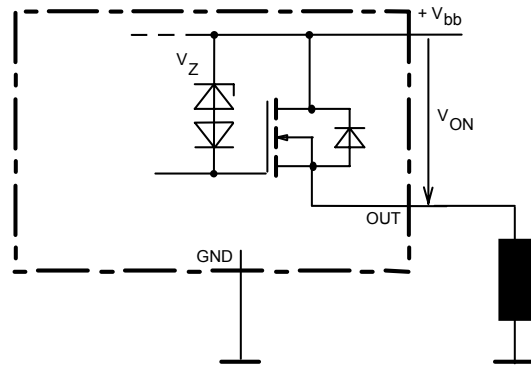


For defined decoupling and high reproducibility the same choke and the same 150Ω -matching network as for the emission measurement is used.

**Terms**

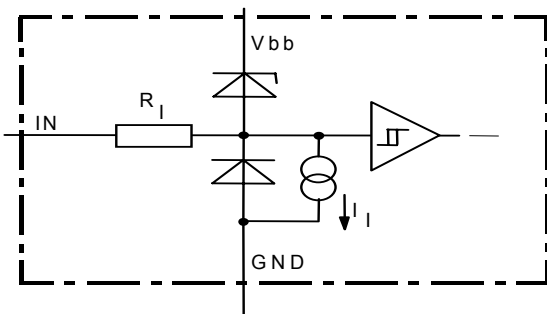


**Inductive and overvoltage output clamp**



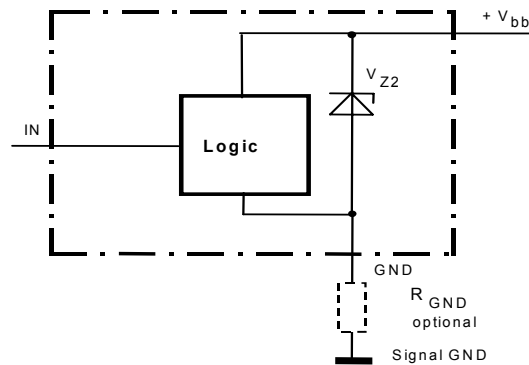
$V_{ON}$  clamped to 63 V min.

**Input circuit (ESD protection)**



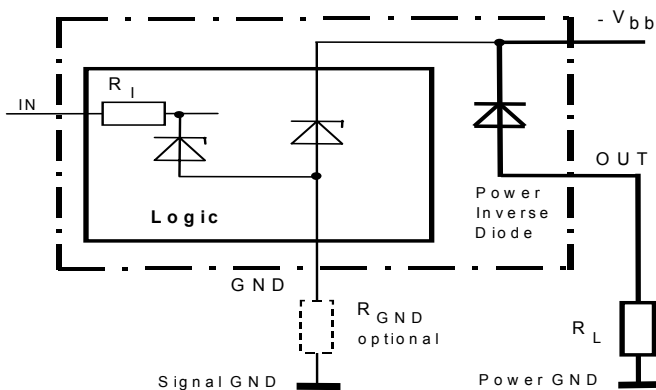
The use of ESD zener diodes as voltage clamp at DC conditions is not recommended

**Overvoltage protection of logic part**



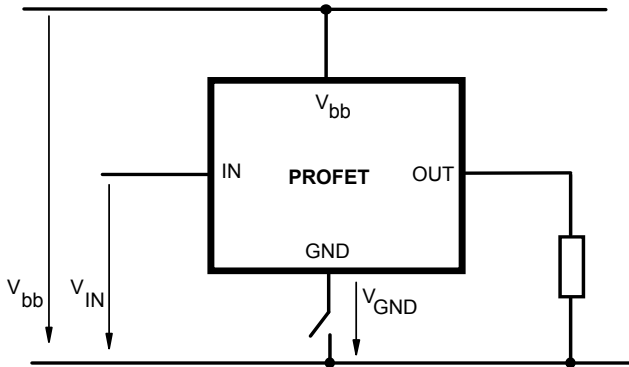
$V_{Z2}=V_{bb(AZ)}=47V$  min.,  
 $R_I=3\text{ k}\Omega$  typ.,  $R_{GND}=150\Omega$

**Reverse battery protection**

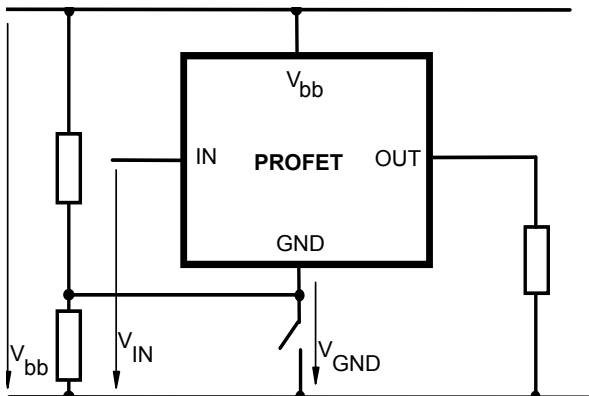


$R_{GND}=150\Omega$ ,  $R_I=3\text{ k}\Omega$  typ.,  
 Temperature protection is not active during inverse current

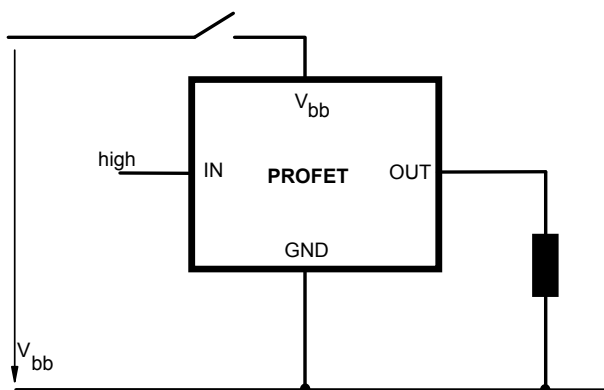
**GND disconnect**



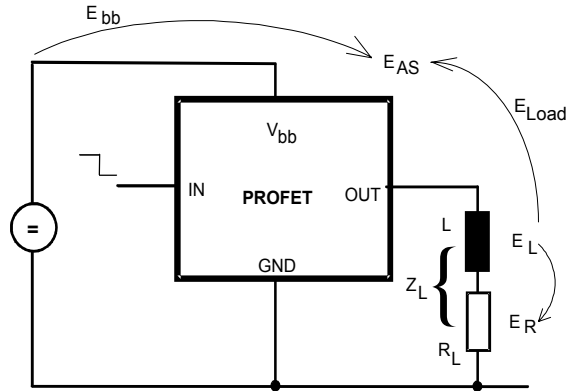
**GND disconnect with GND pull up**



**V<sub>bb</sub> disconnect with charged inductive load**



**Inductive Load switch-off energy dissipation**



Energy stored in load inductance:  $E_L = \frac{1}{2} * L * I_L^2$

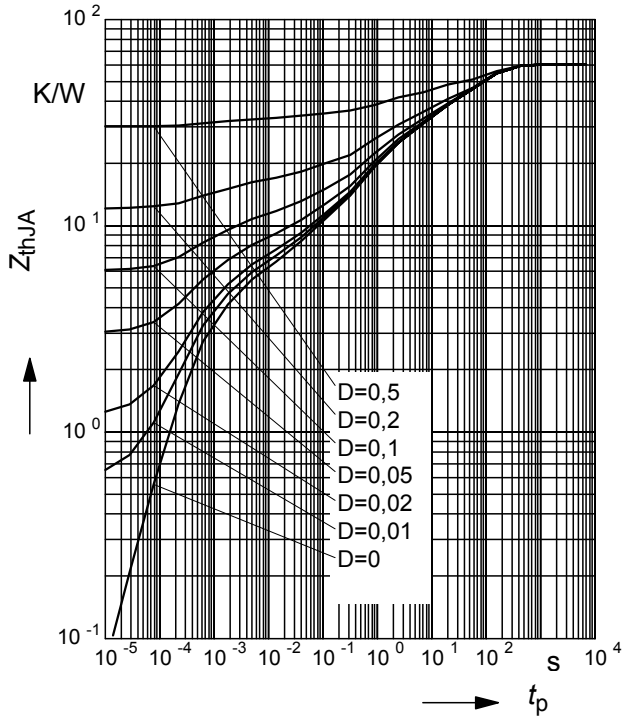
While demagnetizing load inductance, the energy dissipated in PROFET is  $E_{AS} = E_{bb} + E_L - E_R = V_{ON(CL)} * i_L(t) dt$ , with an approximate solution for  $R_L > 0\Omega$ :

$$E_{AS} = \frac{I_L * L}{2 * R_L} * (V_{bb} + |V_{OUT(CL)}|) * \ln\left(1 + \frac{I_L * R_L}{|V_{OUT(CL)}|}\right)$$

**Typ. transient thermal impedance**

$Z_{thJA} = f(t_p)$  @ 6cm<sup>2</sup> heatsink area

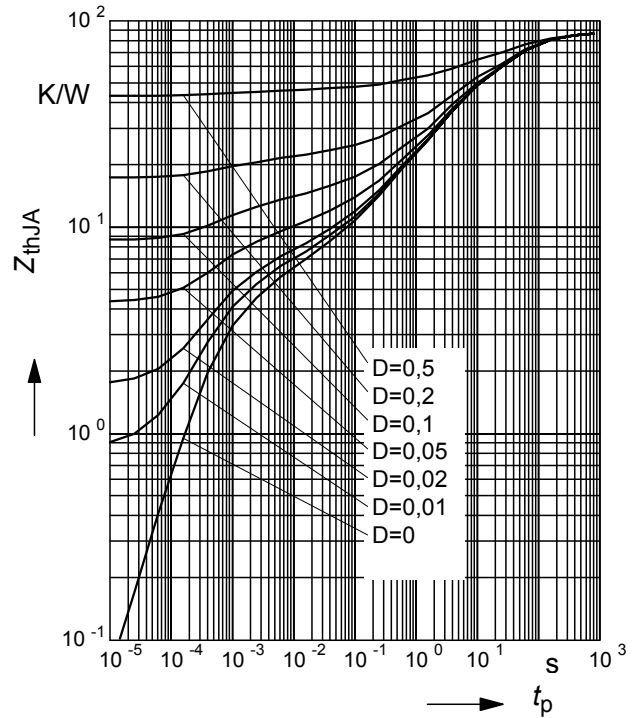
Parameter:  $D = t_p / T$



**Typ. transient thermal impedance**

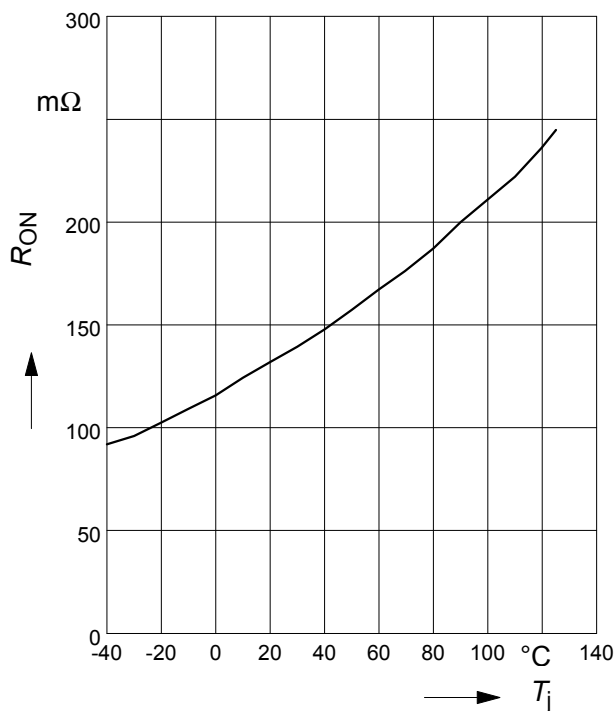
$Z_{thJA} = f(t_p)$  @ min. footprint

Parameter:  $D = t_p / T$



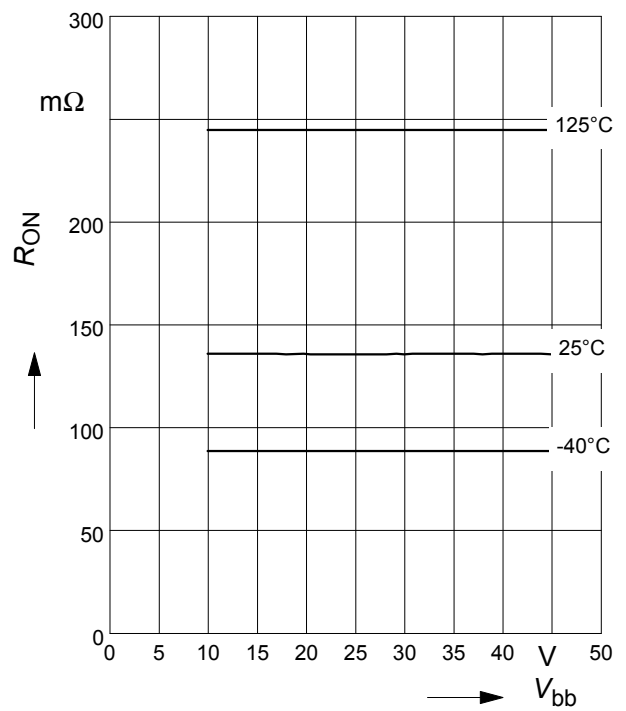
**Typ. on-state resistance**

$R_{ON} = f(T_j)$ ;  $V_{bb} = 15\text{ V}$ ;  $V_{in} = \text{high}$



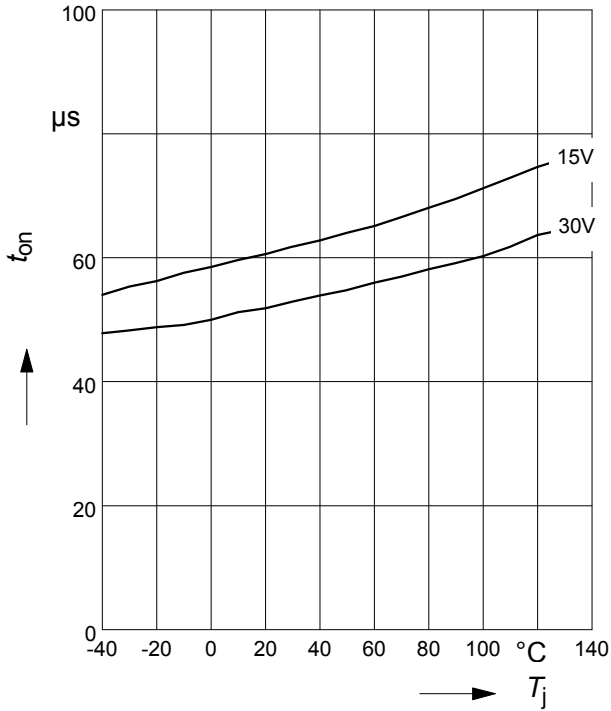
**Typ. on-state resistance**

$R_{ON} = f(V_{bb})$ ;  $I_L = 0.5\text{ A}$ ;  $V_{in} = \text{high}$



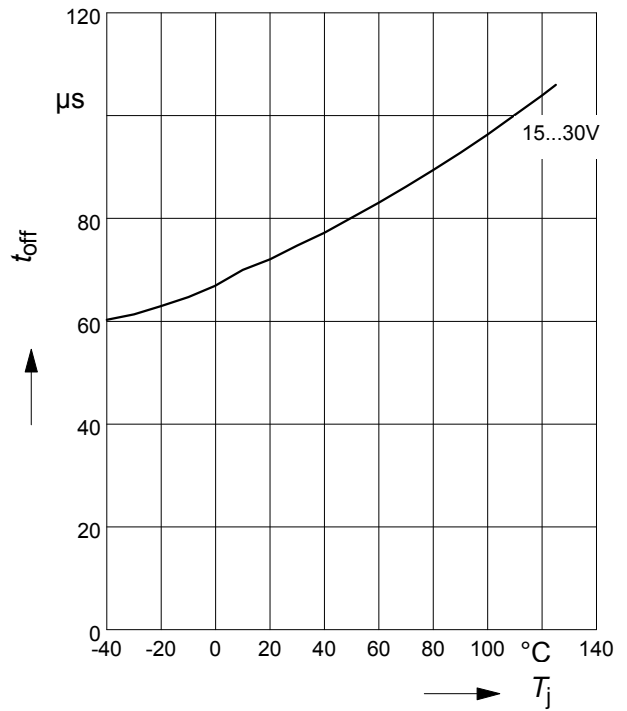
**Typ. turn on time**

$t_{on} = f(T_j); R_L = 47\Omega$



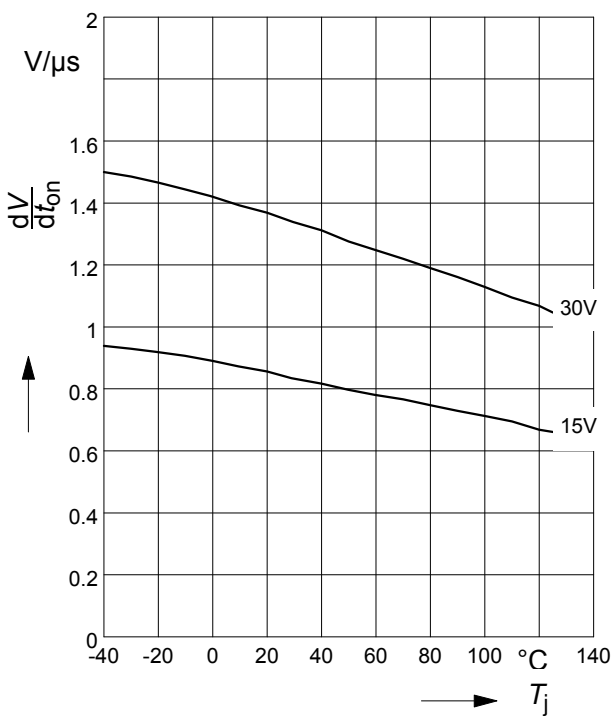
**Typ. turn off time**

$t_{off} = f(T_j); R_L = 47\Omega$



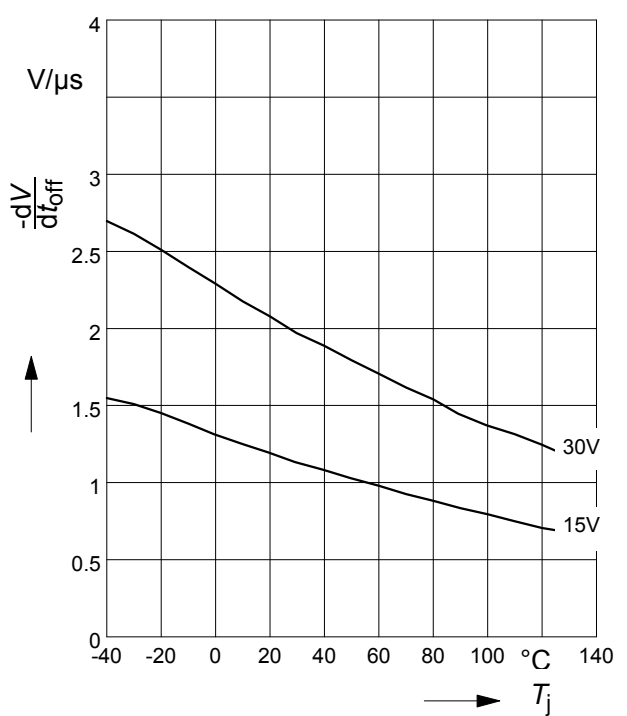
**Typ. slew rate on**

$dV/dt_{on} = f(T_j); R_L = 47\Omega$



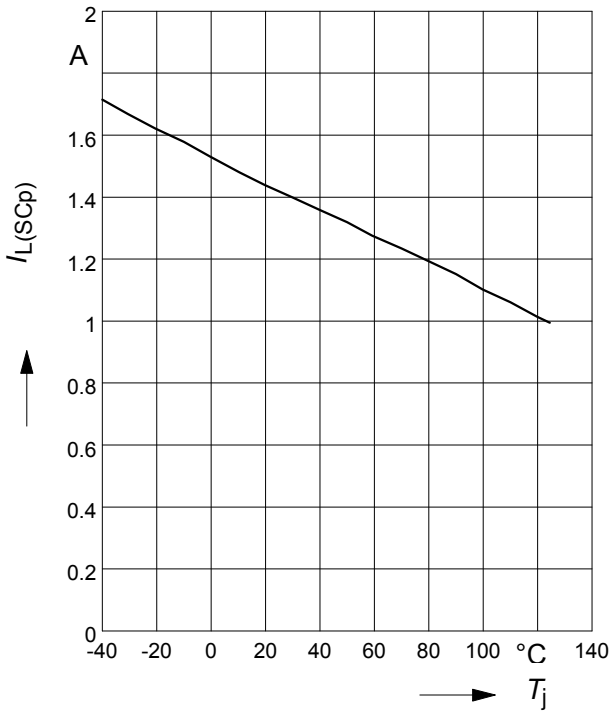
**Typ. slew rate off**

$dV/dt_{off} = f(T_j); R_L = 47\Omega$



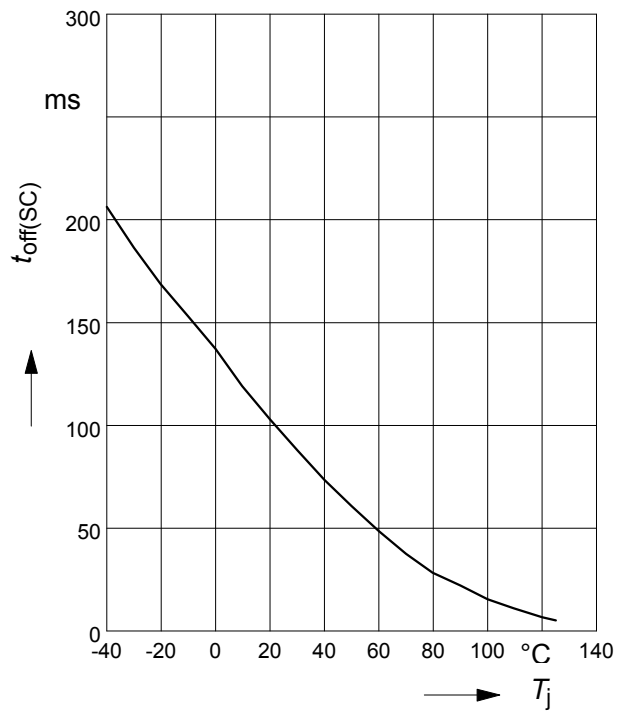
**Typ. initial peak short circuit current limit**

$I_{L(SCp)} = f(T_j)$ ;  $V_{bb} = 20V$ ;  $t_m = 150\mu s$



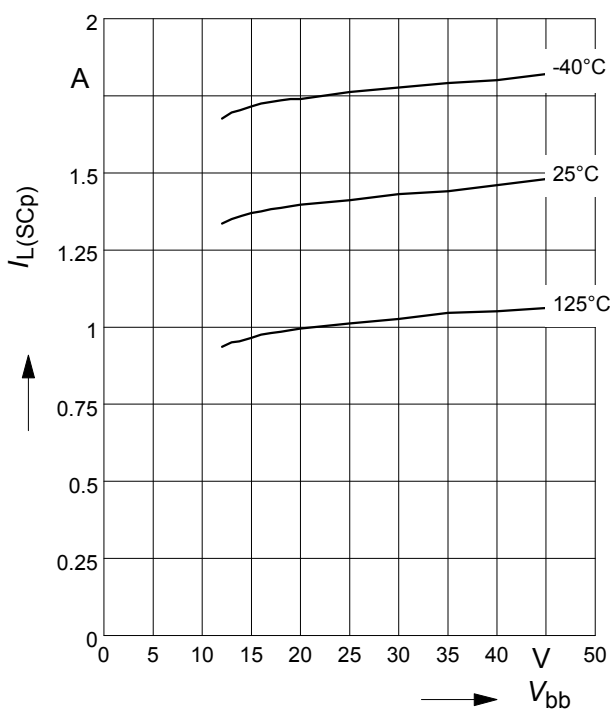
**Typ. initial short circuit shutdown time**

$t_{off(SC)} = f(T_{j,start})$ ;  $V_{bb} = 20V$



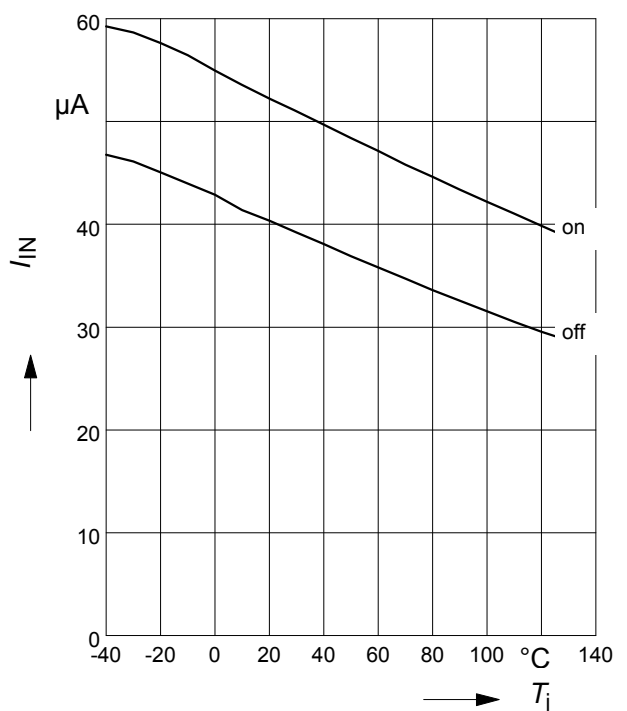
**Typ. initial peak short circuit current limit**

$I_{L(SCp)} = f(V_{bb})$ ;  $t_m = 150\mu s$



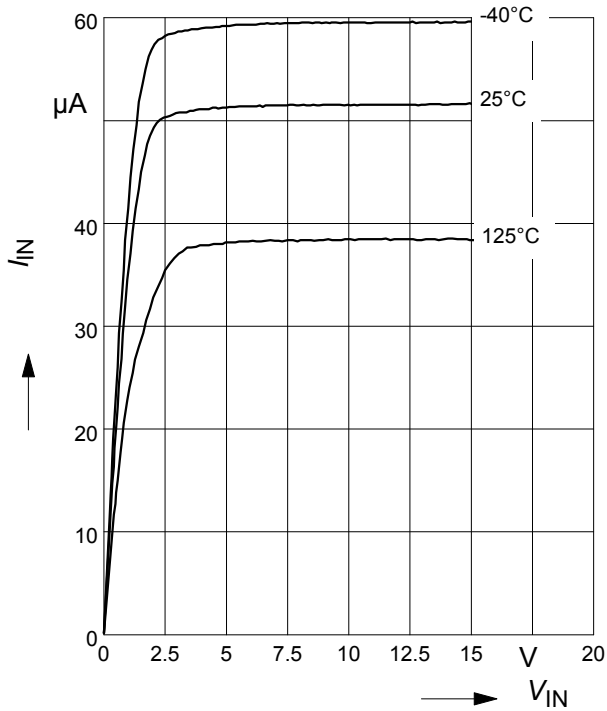
**Typ. input current**

$I_{IN(on/off)} = f(T_j)$ ;  $V_{bb} = 15V$ ;  $V_{IN} = \text{low/high}$   
 $V_{INlow} \leq 1,8V$ ;  $V_{INhigh} = 5V$



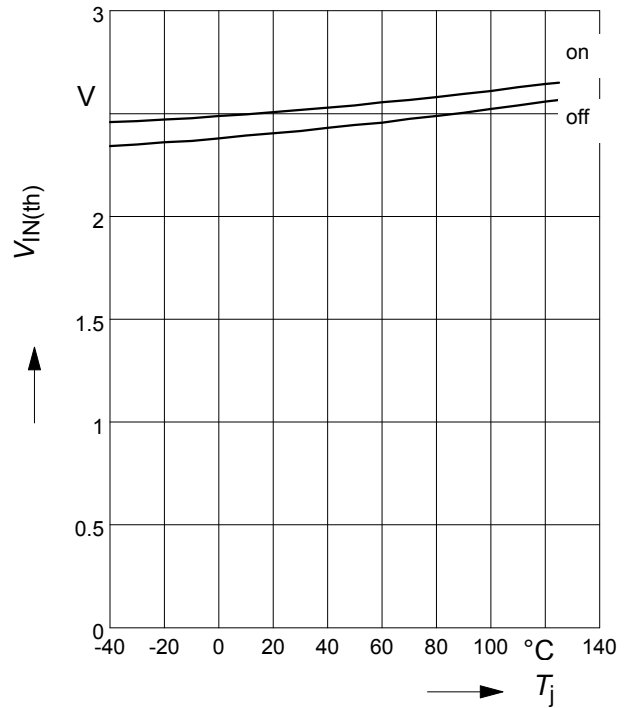
**Typ. input current**

$I_{IN} = f(V_{IN}); V_{bb} = 15\text{ V}$



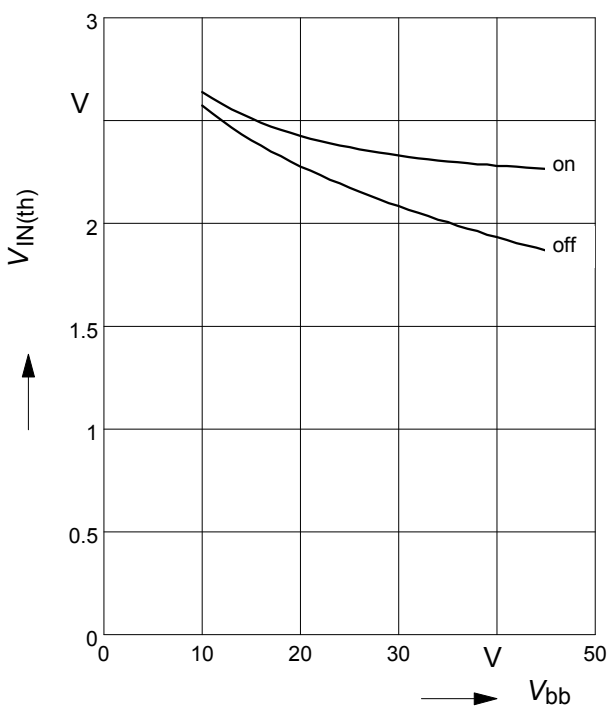
**Typ. input threshold voltage**

$V_{IN(th)} = f(T_j); V_{bb} = 15\text{ V}$



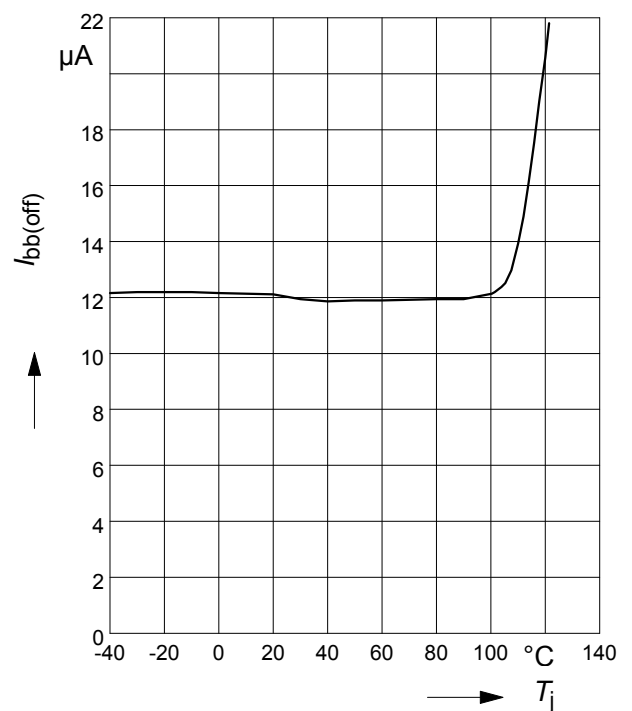
**Typ. input threshold voltage**

$V_{IN(th)} = f(V_{bb}); T_j = 25^\circ\text{C}$



**Typ. standby current**

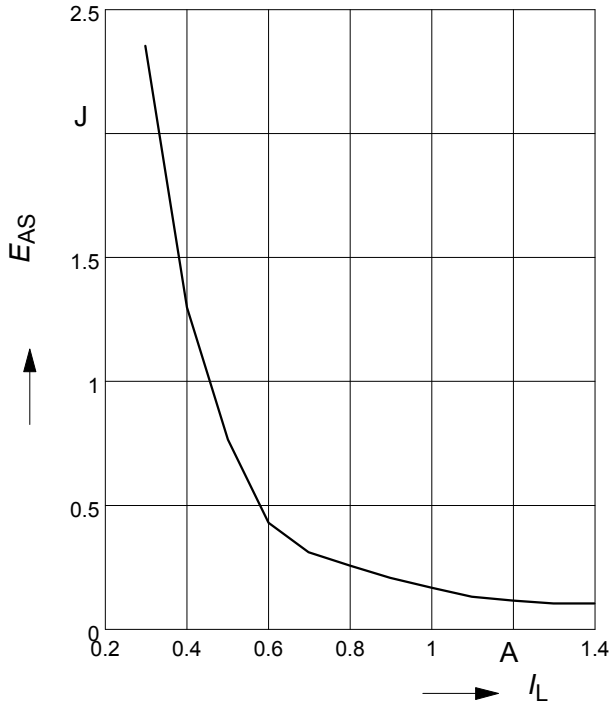
$I_{bb(off)} = f(T_j); V_{bb} = 32\text{ V}; V_{IN} \leq 1,2\text{ V}$





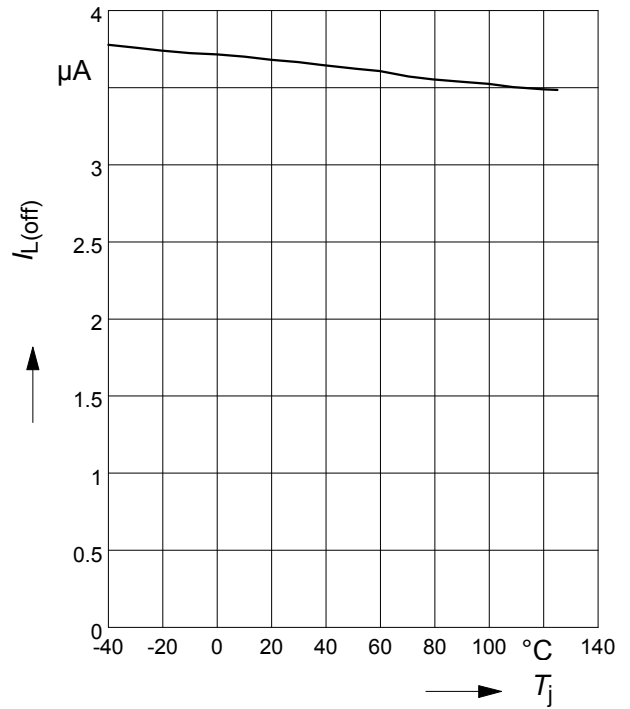
**Maximum allowable inductive switch-off energy, single pulse**

$E_{AS} = f(I_L); T_{jstart} = 125^{\circ}C$



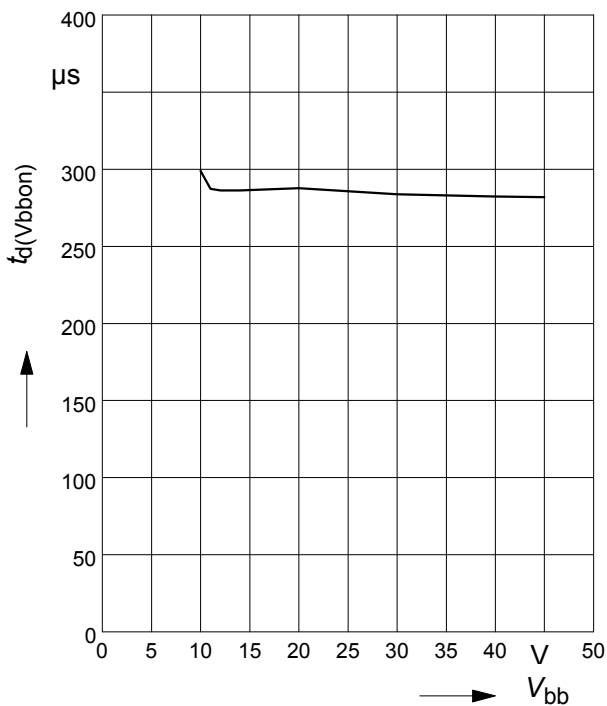
**Typ. leakage current**

$I_{L(off)} = f(T_j); V_{bb} = 32V; V_{IN} \leq 1,2 V$



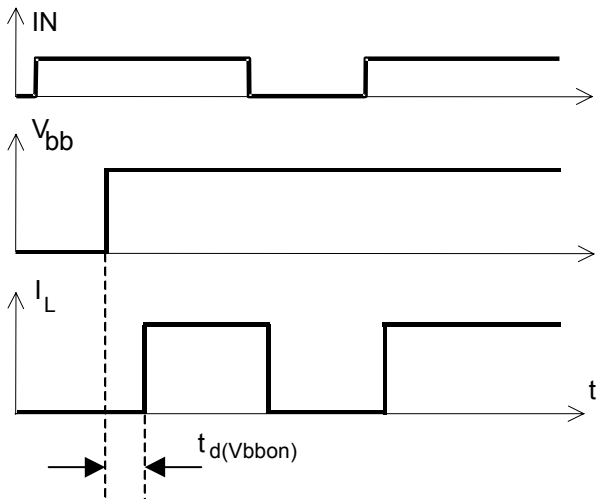
**Typ. input delay time at switch on  $V_{bb}$**

$t_d(V_{bbon}) = f(V_{bb})$

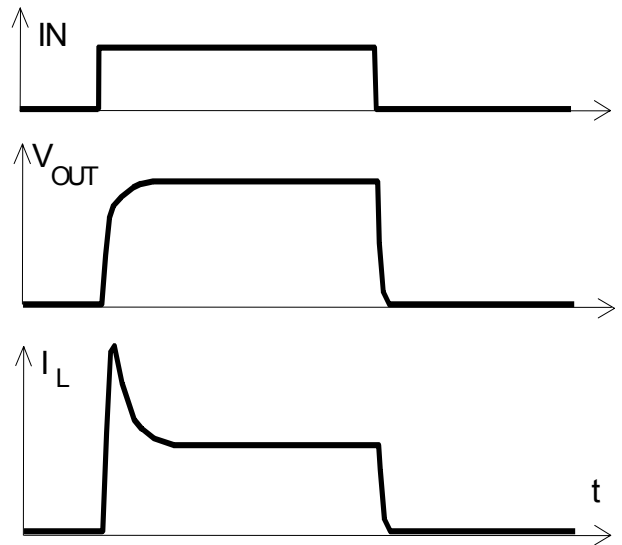


**Timing diagrams**

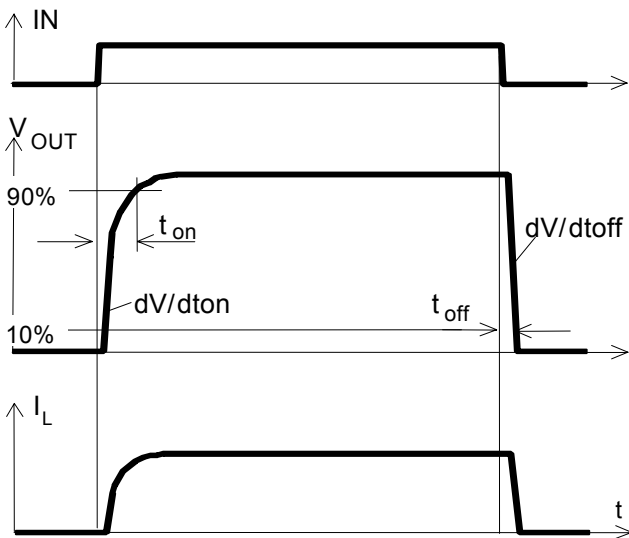
**Figure 1a: Vbb turn on:**



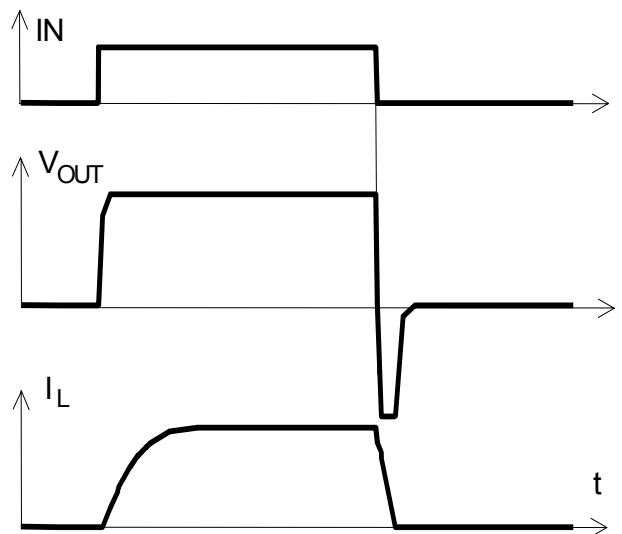
**Figure 2b: Switching a lamp**



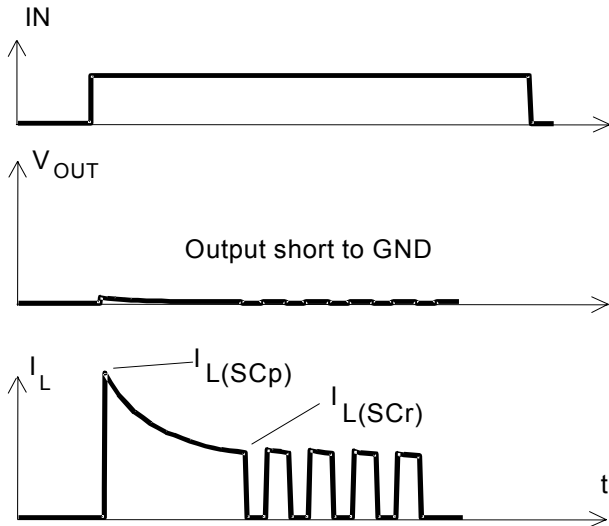
**Figure 2a: Switching a resistive load, turn-on/off time and slew rate definition**



**Figure 2c: Switching an inductive load**

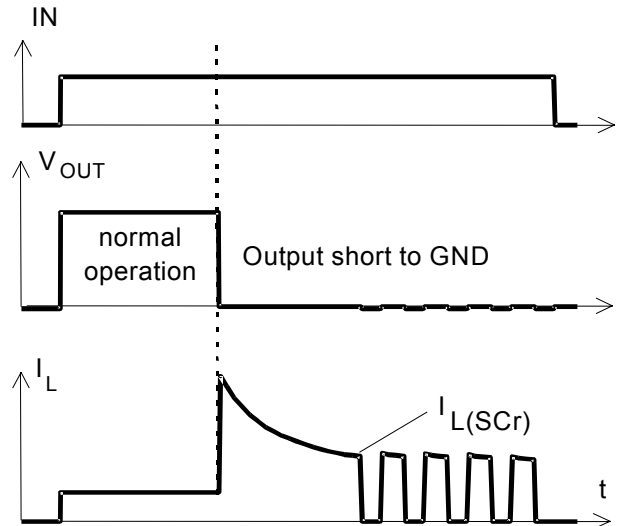


**Figure 3a:** Turn on into short circuit, shut down by overtemperature, restart by cooling

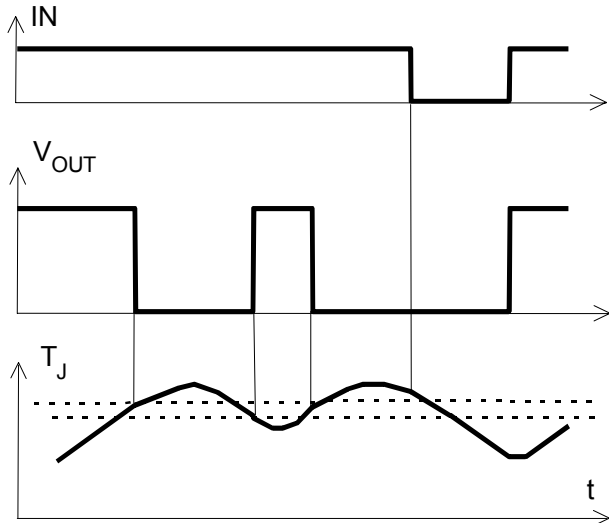


Heating up of the chip may require several milliseconds, depending on external conditions.

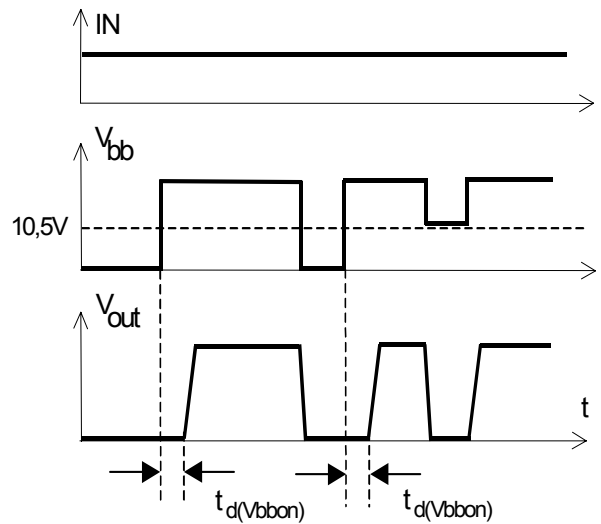
**Figure 3b:** Short circuit in on-state shut down by overtemperature, restart by cooling



**Figure 4:** Overtemperature: Reset if  $T_j < T_{jt}$



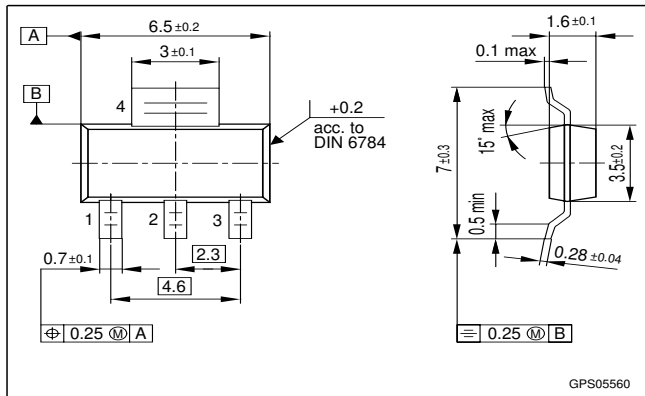
**Figure 5:** Undervoltage shutdown and restart



## Package and ordering code

all dimensions in mm

Sales code	ITS 4141N
Ordering code, standard (1000 pcs.)	SP000219536



**Published by**  
**Infineon Technologies AG,**  
**St.-Martin-Strasse 53,**  
**D-81669 München**  
**© Infineon Technologies AG 2001**  
**All Rights Reserved.**

### Attention please!

The information herein is given to describe certain components and shall not be considered as a guarantee of characteristics.

Terms of delivery and rights to technical change reserved.

We hereby disclaim any and all warranties, including but not limited to warranties of non-infringement, regarding circuits, descriptions and charts stated herein.

Infineon Technologies is an approved CECC manufacturer.

### Information

For further information on technology, delivery terms and conditions and prices please contact your nearest Infineon Technologies Office in Germany or our Infineon Technologies Representatives worldwide (see address list).

### Warnings

Due to technical requirements components may contain dangerous substances. For information on the types in question please contact your nearest Infineon Technologies Office.

Infineon Technologies Components may only be used in life-support devices or systems with the express written approval of Infineon Technologies, if a failure of such components can reasonably be expected to cause the failure of that life-support device or system, or to affect the safety or effectiveness of that device or system. Life support devices or systems are intended to be implanted in the human body, or to support and/or maintain and sustain and/or protect human life. If they fail, it is reasonable to assume that the health of the user or other persons may be endangered.