



HESTORE.HU

elektronikai alkatrész áruház

EN: This Datasheet is presented by the manufacturer.

Please visit our website for pricing and availability at www.hestore.hu.

**Bluetooth Low Energy (BLE)
Pass-through Module Specification**

HM-BT4502

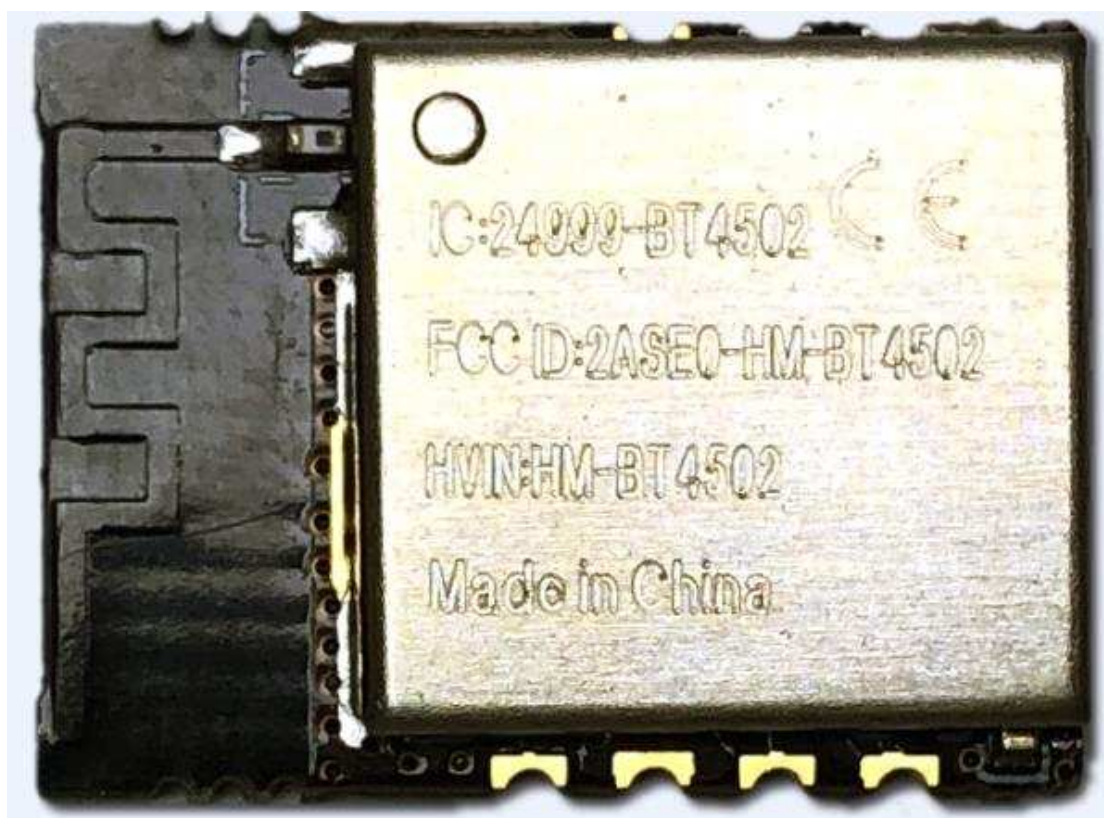

Table of Contents

1	Product Overview	4
2	Module Features.....	4
3	Electrical Characteristics	6
4	Module Function Description.....	6
5	Application Schematic	7
6	Module Pins	8
	6.1 Module Pins Distribution.....	8
	6.2 Module Pins Definition.....	9
7	Module Size	10
8	Serial Port Pass-through Protocol Description.....	10
9	Serial Port AT Instructions.....	13
	9.1 Set the Connection Interval.....	13
	9.2 Get the Module Name	14
	9.3 Rename the Module	14
	9.4 Get the Baud Rate.....	14
	9.5 Set the Baud Rate	14
	9.6 Get the Module MAC Address	15
	9.7 Set the Module MAC Address.....	15
	9.8 Module Reset	16
	9.9 Set the Advertisement Period	16

9.10	Add the Custom Advertisement Content.....	16
9.11	Customizethe Product Identification.....	17
9.12	Tx Power Setting	18
9.13	RSSI Signal Strength Output	18
9.14	RTC Setting and Getting	19
9.15	Data Delay Setting	19
9.16	Battery Level Setting	20
9.17	AT Instruction List.....	20
9.18	Advertisement Data Setting.....	24
9.19	System Reset and Recovery.....	26
10	BLE Protocol Description (APP Interface).....	27
10.1	Pass-through Data Channel 【Service UUID : 0xFFE0】	27
10.2	Anti-hijacking Key 【Service UUID : 0xFFC0】	28
10.3	Module Parameter Setting 【Service UUID : 0xFF90】	31
10.4	OTA Service 【Service UUID: 0x5833ff01-9b8b-5191-6142-22a 4536ef123】	37
10.5	Device Information 【Service UUID: 0x180A】	37

1 Product Overview

HM-BT4502 is a wireless data pass-through module based on CMT4502 Bluetooth Low Energy 5.0 chip. By connecting with MCU, it can quickly realize the connection and data communication between the module and Bluetooth devices such as smartphones and tablets. MCU takes up less resource and development is simple.

2 Module Features

- Easy to use without any experience in Bluetooth stack application.
- User interface uses universal serial port design, full-duplex two-way communication, minimum baud rate support 9600 bps;
- Default connection interval is 30 millisecond, fast connection;
- Support 2M symbol transmission;
- Support 244 bytes packet transmission;
- Support AT instruction for software reset and get MAC address;
- Support AT instruction to set Bluetooth connection interval and control different forwarding rates (dynamic power adjustment);
- Support AT instruction to adjust Tx power, modify advertisement interval, customize advertisement data, customize device identification, set data delay (user MCU serial port reception preparation time),

modify serial port baud rate, modify module name. All the above parameters are saved after power-down;

- Serial port package length can be any length within 240 bytes (including 240 bytes) (automatic distribution of large packages);
- Support mobile device APP to modify module name, serial baud rate, product identification code, and customize advertisement content and advertisement period. These settings can be saved after power-down.
- Support mobile device APP to reset module and set Tx power remotely.
- Support mobile device APP to adjust Bluetooth connection interval. The setting can not to be saved after power down.
- Support anti-hijacking password settings, modification and recovery. Prevent malicious third party connections. Users can also not use them.
- Advertisement Content prompt the module real-time system status, including battery power, custom device identification code (suitable for advertisement application);
- Support internal RTC (real-time clock);

3 Electrical Characteristics

- Working voltage: 1.8V-3.6V
- Working temperature: - 40°C~125°C (built-in BLE main IC working range)
- Modulation mode: GFSK (Gaussian Frequency Shift Keying)
- Modulation frequency: 2402MHz-2480MHz
- Transient current of receiving data: less than 8mA@3V
- Transient current of sending data: less than 8mA@3V@0dBm
- Current in the low power mode: less than 4uA@3V
- Tx power: - 20dBm ~+8dBm
- Rx sensitivity: -97dBm

4 Module Function Description

After the module starts, it advertises automatically. The opened specific APP on the mobile phone will scan and connect it. After successful connection, it can be operated through BLE protocol. User-controlled MCU can realize the communication with the mobile device through the serial port of the module. Users can also manage and control some communication parameters through the specific interface instruction.

User data format is defined by upper application program. Mobile devices

can write to the module through APP, and the written data will be sent to the user's MCU through the module's external interface. When the module external interface receives the data package from the external MCU, it will automatically forward it to the connected mobile device. Users need to design the main MCU code and the smart mobile device APP.

5 Application Schematic



Figure 1. Application Schematic of the Pass-through Module

6 Module Pins

6.1 Module Pins Distribution

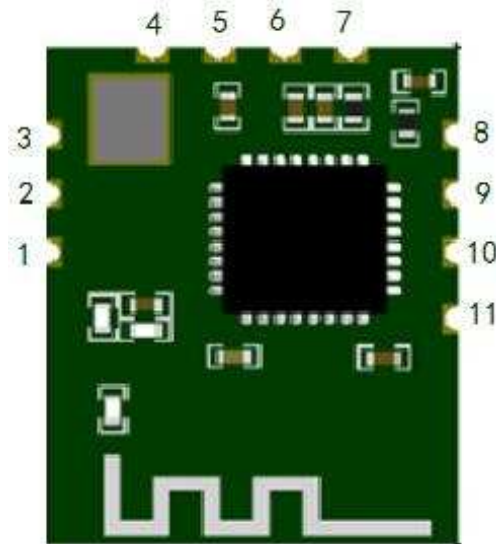

Fig. 2. Module Pins Distribution Diagram (Top View)

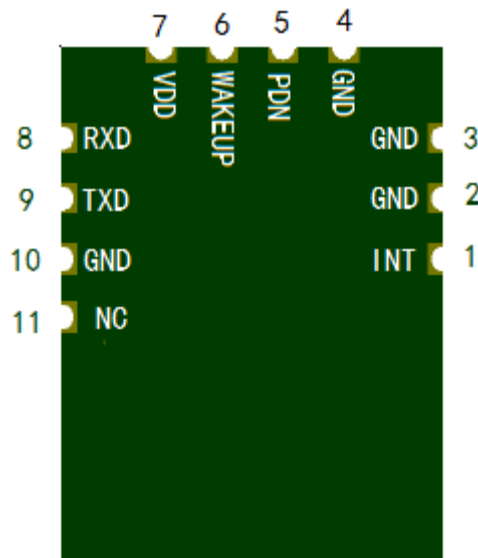

Fig. 3. Module Pins Distribution Diagram (Bottom View)

6.2 Module Pins Definition

Pin No	Pin Name	Type	Description
1	INT	DO	Interrupt Request
2	GND	DG	Digital Ground
3	GND	DG	Digital Ground
4	GND	DG	Digital Ground
5	PDN	DI	Power Down Control,
6	WAKEUP	DI	Wakeup Pin
7	VDD	AP,DP	Power Supply; 1.8V~3.6V
8	UART_RXD	DI	UART RXD
9	UART_TXD	DO	UART TXD
10	GND	DG	Digital Ground

Table 1. Module Pin Definition

7 Module Size

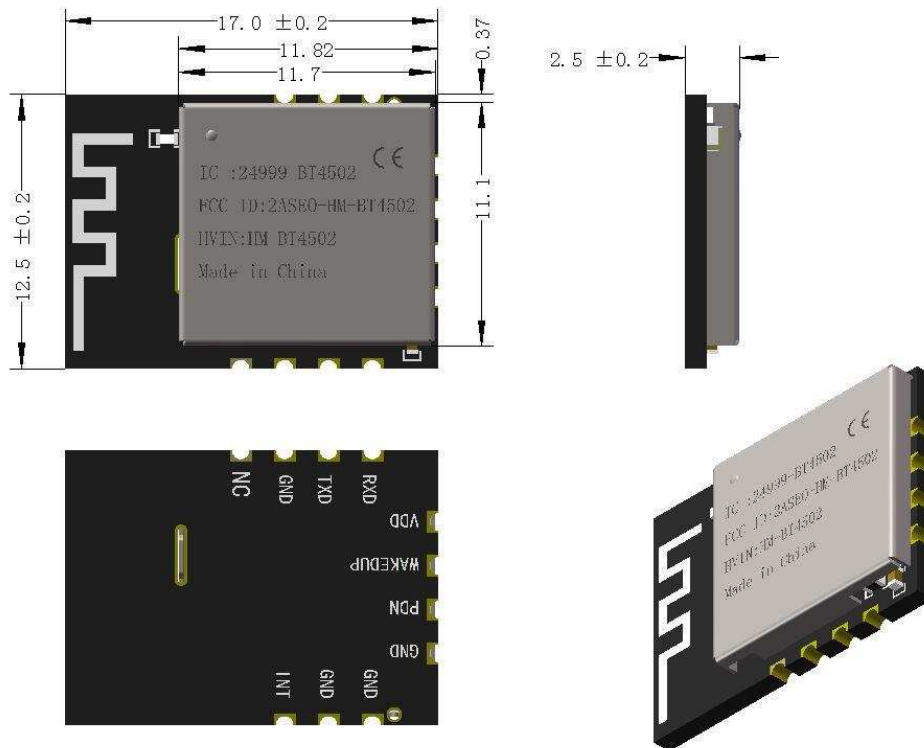

Fig4. Module Size Diagram

8 Serial Port Pass-through Protocol Description

The module connects with the user MCU through the serial port, and establishes the bidirectional communication between the user MCU and the mobile device. Users can set the serial baud rate and BLE connection interval again by using the specified AT instruction through the serial port (See the chapter of *Serial AT Instructions* for details). The Module will have different data throughput capabilities according to different serial baud rates, BLE connection interval and different sending packages interval. The default serial

port baud rate is 115200 bps. In the level enable mode, the following is a detailed description of the pass-through protocol for this configuration. The module can send up to 240bytes of packages at one time from the serial port. The module will subcontract or send the complete data package according to Bluetooth protocol. The data packets sent by mobile devices to modules must be sent according to protocols. After the module receives these packages, it will forward them to the host serial port instantly.

1. Serial port hardware protocol parameter: 115 200 bps, 8 is No Check Bit, 1 is Stop Bit.
2. When the PDN is in high level then the Bluetooth module is in full sleep state. When the PDN is set from high to low (edge trigger), the module will start advertisement with 200ms intervals until the successful connection with the mobile phone. When the PDN jumps from the low level to the high level, the module will go to the sleep immediately regardless of the module status.
3. When the module has a request for data upload to MCU, it will set the INT low and start sending the data after 1ms at the earliest until the data has been sent. This delay can be configured by the AT instruction, see the chapter of *Serial AT Instructions*. After sending the data, the module will set the INT high.
4. When the external MCU sends the data to the module through the serial

port, it needs to pull the WAKEUP pin from the high level to the low level to generate a falling edge to wake up the module (because it takes 1ms to wake up the module to be ready, so the minimum delay between the falling edge of WAKEUP pin and the serial port data reception is 1ms). After sending the data, the WAKEUP pin will be pulled from the low level to the high level, and the module will enter the Sleep mode again.

5. After successful module connection, the "TTM: CONNECT\r\n\r\n0" string is sent from TX, which can be used to determine whether normal forwarding operation can be performed. Of course, users can also send a specific confirmation string to the module through the mobile phone; the host can confirm the connection after receiving it. If the connection is actively disconnected by the APP, the "TTM:DISCONNECT\r\n\r\n0 " string will be sent from TX. If the connection is abnormally disconnected, the "TTM:DISCONNECT FOR TIMEOUT\r\n\r\n0"string will be sent from TX.
6. The size of serial data package can be variable, and the length can be any value within 240 bytes, which can also satisfy the above conditions. However, in order to make the most efficient use of communication payload and avoid full-load operation of communication, it is recommended to use 100, 200, 240 bytes of serial data packages with package interval greater than 20ms.

9 Serial Port AT Instructions

The string beginning with "TTM" is parsed and executed as an AT instruction and returned the execution result "TTM: OK\r\n\0" or "TTM: ERP\r\n\0", etc.

The serial data package that does not start with "TTM" will be considered as the pass-through data.

9.1 Set the Connection Interval

Input the string "TTM: CIT-X ms" to the serial port RX to set BLE connection interval, where X= "20", "30", "50", "100", "200", "300", "400", "500", "1000", "1500", "2000". The unit is ms (the above data format is ASCII code). For example, "TTM: CIT-30ms" means setting the connection interval to 30ms.

After executing this instruction, the following confirmation will be obtained from serial TX:

"TTM: TIMEOUT\r\n\0" means that the change timed out and failed.

"TTM: OK\r\n\0" means that the change is successful and the program is running at a new connection interval.

The success of this connection interval setting depends on the limitation of the mobile device on the interval, and the maximum connection interval varies from the mobile phone system version.

Note: This connection interval is not saved when power fails, and the change instructions valid only after the connection is successful.

9.2 Get the Module Name

Input the following string "TTM: NAM-?" to the serial port RX.

It will receive the "TTM: NAM-xxxxxxxxxxxx\r\n\0" from TX. The "xxxxxxxxxxxx" following the string is the Bluetooth module name.

9.3 Rename the Module

Input the string "TTM: REN- Name " to the serial port RX, where "Name" is the module name, the length is within 15bytes in ASCII format.

For example, "TTM: REN-ABC123" means renaming the module "ABC123".

If the modification is successful, the confirmation string "TTM: OK\r\n\0" will be received from TX. If the instruction format is incorrect, the string "TTM: ERP\r\n\0" will be received. This name can be saved after power-down.

9.4 Get the Baud Rate

Input the string "TTM: BPS-?" to the serial port RX to get the baud rate.

"TTM: BPS-X" will be received from TX, among them, X= "9600", "19200", "38400", "57600", "115200" (the above data formats are ASCII codes).

9.5 Set the Baud Rate

Input the string "TTM: BPS-X" to the serial port RX to set the baud rate, among them, X= "9600", "19200", "38400", "57600", "115200" (the above data format

is ASCII code). For example, "TTM: BPS-115200" indicates that the baud rate is 115200 bps. After executing this instruction, the following confirmation string "TTM: BPS SET AFTER 2S..." will be received from the serial port TX. If the setting value is not in the option or the instruction format is incorrect, the string "TTM: ERP\r\n\0" will be received.

Tests show that the baud rate modification cannot be successful in IOS5, but it can be changed immediately in IOS6. Users can set it through PC or BLE APP of mobile devices. See the Chapter of *Module Parameter Settings [Service UUID: 0xFF90]*.

9.6 Get the Module MAC Address

Input the string "TTM: MAC-? \r\n\0" to the serial port RX.

"TTM: MAC-xxxxxxxxxxxx\r\n\0" will be received from TX.

The "xxxxxxxxxxxx" following the string is the Bluetooth module physical address. The size is 6 bytes.

9.7 Set the Module MAC Address

Input the string "TTM: MAC-xxxxxxxxxxxx" to the serial port RX.

If the instruction format is correct, the "TTM: OK\r\n\0" will be received from TX.

If the format is incorrect, the "TTM: ERP\r\n\0" will be received.

This setting can be saved on power failure. When the module restarts, it will

run according to the new MAC address.

9.8 Module Reset

Input the string "TTM: RST-SYSTEMRESET" to the serial port RX:

It will force the module to soft reset once.

9.9 Set the Advertisement Period

Input the string "TTM: ADP-(X)" to the serial port RX to set the advertisement period of the module, $T = X * 100\text{ms}$.

Among them, $X = "2", "5", "10", "15", "20", "25", "30", "40", "50"$ (all data formats above are ASCII codes). For example, "TTM:ADP-(2)" means the advertisement period is 200ms. If the instruction format is correct, the confirmation string "TTM: OK\r\n\r\n0" will be received from TX. If the format is incorrect, the "TTM: ERP\r\n\r\n0" will be received. This setting can be saved on power failure. When the module restarts, it will run according to the new advertisement period.

9.10 Add the Custom Advertisement Content

Input the following strings to the serial port RX to customize the advertisement content.

"TTM: ADD-" + Data

Among them, Data is the added advertisement content, the length is $0 < L \leq 16$,

the format is ASCII code. For example, input the "TTM: ADD - Advertisement" to the serial port RX. The confirmation string "TTM: OK\r\n\0" will be received from TX. If the instruction format is incorrect, the "TTM: ERP\r\n\0" will be received.

This instruction will take effect immediately after it is set up. Users can advertise some custom content through this function. This setting is power down saved. If the setting is all 0 (16 bytes), the default advertisement content is used instead of the custom advertisement.

9.11 Customize the Product Identification

Input the following string to the serial port RX to customize the product identification.

"TTM: PID-"+ Data

Among them, Data is a product identification code of two bytes, ranging from 0x0000 to 0xFFFFFFFF (L = 2), and each character is input to the serial port RX in ASCII code format. For example, input the "TTM: PID-RS" to the serial port RX ("RS" corresponds to hexadecimal 0x5253). If the instruction format is correct, the confirmation string "TTM: OK\r\n\0" will be received from TX. If the format is incorrect, the "TTM: ERP\r\n\0" will be received.

Note: This ID code will be saved on power failure. It can be used to filter the device or determine whether it is a specific product in the advertisement.

9.12 Tx Power Setting

Input the following string to the serial port RX. Set the corresponding Tx power.

The unit is dBm.

"TTM: TPL-(X)"

Among them, X="+10", "+6", "0", "-6", "-10", "-20" (the above data formats are

ASCII codes). For example, "TTM:TPL-(+6)" means that the Tx power is

+6dBm. If the instruction format is correct, the confirmation string "TTM:

OK\r\n\r\n0" will be received from TX, and the module will immediately run the

new Tx power to communicate. If the format is not correct, the "TTM:

ERP\r\n\r\n0" will be received.

Note: This parameter is not saved on power failure.

9.13 RSSI Signal Strength Output

Input the string "TTM: RSI-ON" to the serial port RX. Open the RSSI output.

The signal strength outputs periodically, the time interval is 1 second.

Input the string "TTM: RSI-OFF" to the serial port RX. Close the RSSI output.

If the setting is successful, the confirmation string "TTM: OK\r\n\r\n0" will be

received from TX. If the instruction format is incorrect, the "TTM: ERP\r\n\r\n0"

will be received.

If RSSI output function is turned on, RSSI signal strength string "TTM:

RSI-xx\r\n\r\n0" is output every one second.

For example, RSSI is - 63dBm. The output string is "TTM: RSI-63\r\n\r\n0"

Note: This parameter is not saved on power failure, and RSSI output is automatically closed after disconnection.

9.14 RTC Setting and Getting

Input the string "TTM: RTC-xxxxxxxxxxxxx" to the serial port RX and set the RTC time. The format is that Year is 4 bits, Month, Day, Hour, Minute and Second is 2 bits respectively.

For example, January 2, 2017, at 3:4:5, the output string is "TTM: RTC-20170102030405\r\n\r\n0"

If the setting is successful, the confirmation string "TTM: OK\r\n\r\n0" will be received from TX. If the instruction format is incorrect, the "TTM: ERP\r\n\r\n0" will be received.

Input the string "TTM: RTC-?" to the serial port RX and get the RTC time.

If the setting is successful, the string "TTM: RTC-xxxxxxxxxxxxx\r\n\r\n0" will be received from TX. The format is the same as the setting format. If the instruction format is incorrect, the "TTM: ERP\r\n\r\n0" will be received.

Note: This parameter is not saved on power failure, and RTC needs to be set again when the module is powered on again.

9.15 Data Delay Setting

Input the string "TTM: CDL-Xms" to the serial port RX and set the delay

between the INT setting and the TX output. The unit is ms.

Among them, X= "0", "2", "5", "10", "15", "20", "25". If the instruction is correct, the confirmation string "TTM: OK\r\n\r\n0" will be received from TX. If the instruction format is incorrect, the "TTM: ERP\r\n\r\n0" will be received.

In order to have enough time to wake up the MCU from the sleep status, the module provides the delay (X) setting. The module sets the INT to the low level before the serial port TX outputs the data. The delay between the INT setting and the TX output is decided by this parameter. The minimum delay is not less than X. The actual delay is $T = (X + Y)$ ms, of which $500\mu s < Y < 1ms$. This parameter is saved on power failure.

9.16 Battery Level Setting

The module has no ADC voltage sampling; it needs the MCU to provide the battery voltage. The MCU sends the string "TTM: BST-Xrn0" from serial port, where X is the percentage of the remaining capacity in decimal system. If the data is sent correctly, the module returns the string "TTM: OK\r\n\r\n0" through the serial port. If the data is sent incorrectly, the module returns the string "TTM: ERP\r\n\r\n0" through the serial port.

9.17 AT Instruction List

AT Instruction	Power	Parameter Description	Possible Response	Meaning
----------------	-------	-----------------------	-------------------	---------

Format	down save			
TTM:CIT-Xms(valid only after successful connection)	No	X="20" , "30" , "50" , "100" , "200" , "300" , "400" , "500" , "1000" , "1500" , "2000". Set the corresponding BLE connection interval in ms.	TTM:TIMEOUT\r\n\r\n0 TTM:OK\r\n\r\n0 TTM:ERP\r\n\r\n0	Setting is timeout Setting is OK. Setting is Error.
TTM: NAM-?	Yes	Get the module name	TTM: NAM-xxxxxxxxxxxxx, "xxxxxxxxxxxxx" is the module name.	Return the module name
TTM:REN+ Name	Yes	Name means a new module name, any string within 15 bytes in length.	TTM:OK\r\n\r\n0 TTM:ERP\r\n\r\n0	Setting is OK. Setting is Error.
TTM: BPS-?	-	Get the baud rate.	TTM:BPS-X , "X" is the baud rate.	Return the baud rate.
TTM:BPS-X	Yes	X="4800" , "9600" , "19200" , "38400" , "57600" , "115200". Set the corresponding baud rate.	TTM:BPS SET AFTER 2S ... \r\n\r\n0 TTM:ERP\r\n\r\n0	If the setting is OK, the new baud rate will be used after two seconds.

				Setting is Error.
TTM: MAC-?	-	Get the MAC address.	TTM:MAC-xxxxxxx xxxx , "xxxxxxxxxxxx" is the module MAC address.	Return the MAC address.
TTM:MAC-X	Yes	X is a 12-bit MAC character, such as 123456789ABC.	TTM:OK\r\n\r\n0 TTM:ERP\r\n\r\n0	Setting is OK. Setting is Error.
TTM:RST-SYST EMRESET	-	Reset the module system	None	Reset the module
TTM:ADP-(X)	Yes	X ="2","5","10","15","20", "25", "30","40","50". Set the corresponding advertisement period, T = X* 100ms	TTM:OK\r\n\r\n0 TTM:ERP\r\n\r\n0	Set the advertisement period. If the setting is "5", it is 500ms.
TTM:ADD-+ Data	Yes	Data is the custom advertisement data with length L<= 16.	TTM:OK\r\n\r\n0 TTM:ERP\r\n\r\n0	Set the custom advertisement content.
TTM:PID-+ Data	Yes	Data is a custom product identification code with the data length L = 2, the default	TTM:OK\r\n\r\n0 TTM:ERP\r\n\r\n0	Set the custom product identification

		is 0000.		code.
TTM:TPL-(X)	No	X="+10","6","0","-6","-20". Set the corresponding Tx power in dBm.	TTM:OK\r\n\r\n0 TTM:ERP\r\n\r\n0	Set the Tx power.
TTM:RSI-ON	-	Open the RSSI function. Get the RSSI data every 1 second.	TTM:OK\r\n\r\n0 TTM:ERP\r\n\r\n0	Get the RSSI data periodically.
TTM:RSI-OFF	-	Close the RSSI function.	TTM:OK\r\n\r\n0 TTM:ERP\r\n\r\n0	Close the RSSI function.
TTM: RTC-?	-	Get the RTC time.	TTM:RTC-xxxxxxx xxxxxx , "xxxxxxxxxxxxxx" is year, month, day, hour, minute and second.	Get the RTC time.
TTM:RTC-X	-	Set the RTC time. X is year, month, day, hour, minute and second.	TTM:OK\r\n\r\n0 TTM:ERP\r\n\r\n0	Set the RTC time.
TTM: BST-X	No	X is the percentage of the battery level.	TTM:OK\r\n\r\n0 TTM:ERP\r\n\r\n0	Set the percentage of the remaining

				capacity
TTM:CDL-Xms	Yes	X="0", "2", "5", "10", "15", "20", "25". Set the delay between the INT setting and the TX output. The unit is ms.	TTM:OK\r\n\r\n0 TTM:ERP\r\n\r\n0	The minimum delay is not less than X, and the actual delay is X+Yms, 500us<Y<1ms.

Table 2. AT Instruction List

*Note: Bold is the default setting.

9.18 Advertisement Data Setting

Default advertisement data: When the PDN pin of the module is set low, the module will advertise at 200ms intervals. The

GAP_ADTYPE_MANUFACTURER_SPECIFIC (Officially Defined Macro in IOS Programming) domain contains the following contents in the advertisement, and the default advertisement content is 9 bytes:

{

0x00, 0x00, custom device type coding. The default is 00 00, which can be set by AT instruction ;

0x00, 0x00, 0x00, 0x00, undefined ;

0x00,percentage of module power supply, 2.0V = 0% ;

0x00,0x00,undefined ;

}

Custom advertisement data: If the advertisement content is customized using AT instructions, the maximum length is 16 bytes (blue part).The

GAP_ADTYPE_MANUFACTURER_SPECIFIC domain contains the following contents in the advertisement. The length is 2+n bytes:

{

0x00, 0x00, custom device type coding. The default is00 00,which can be set by AT instruction ;

Data [n], custom advertisement data, n <= 16 ;

}

Note: The custom advertisement data can be modified by AT instruction and saved on power failure. When the power is restarted, the final custom advertisement data will be used. If the custom advertisement data is all 0 (16 bytes), it is considered that the default advertisement content of the system is used instead of the custom advertisement. In order to avoid excessive power consumption caused by too long advertisement, the custom advertisement is also possible to set any value of 1 byte.

9.19 System Reset and Recovery

There are three ways to reset the module. The third way can restore the system parameters.

1. Use the AT instruction to reset the module (see the Chapter of *Serial AT Instructions* for details);
2. Use APP to remote reset the module through the service channel interface. (See the chapter of *BLE Protocol Description (APP Interface) - Module Parameter Settings* for details).
3. Use the hardware PDN pin to reset.

After resetting by the above three methods, the parameters marked as not saved on power failure will be reset to the default values in the AT instruction list. In addition, in order to prevent hijacking the password, no password is used by default after restoring to "000000".

In addition, the factory settings can be restored by APP, and all parameters can be restored to the factory default settings. They include:

- a) Serial Port Baud Rate, it is restored to 115200 bps.
- b) Device Name, it is restored to "CMT4501-XXXXXXXX", X is the last four bytes of MAC.
- c) Serial Port Data Delay, it is restored to 0 (500us < Delay < 1ms).
- d) Advertisement Period, It is restored to 2 (200ms).
- e) Connection Interval, it is restored to 30ms.

- f) Product Identification Code, it is restored to 0x00, 0x00.
- g) Tx Power, it is restored to 0dBm.
- h) Custom Advertisement Length, it is restored to 0.
- i) Custom Advertisement Data, it is restored to all 0. Use the default advertisement data instead of custom advertisement data.
- j) Enable Mode, it is restored to 0, the default is the level enable mode.

10 BLE Protocol Description (APP Interface)

10.1 Pass-through Data Channel 【Service UUID : 0xFFE0】

Characteristic UUID	Privilege	Bytes	Default Value	Remark
FFE9 (handle: 0x0013)	Write	20	None	APP Write data to module and output to UART TX.
FFE4 (handle: 0x000E)	notify	20	None	Notify the data from UART RX to BLE APP.

Table 3. Pass-through Data Channel Service

Note: Bluetooth input is forwarded to serial output. After APP writes to this channel through the BLE API interface, the data will be output from the serial port TX. Details see the chapter of *Serial Pass-through Protocol Description (Bridging Mode)*. Serial input is forwarded to Bluetooth output. If the notification EN switch of FFE4 channel is turned on, a notification will be generated in the

channel after the legitimate data sent by the main CPU to the module RX through the serial port. APP can process and used it directly in the callback function. Details see the chapter of *Serial Pass-through Protocol Description (Bridging Mode)*.

10.2 Anti-hijacking Key 【Service UUID : 0xFFC0】

The module supports anti-hijacking encryption. This service can effectively prevent unauthorized mobile devices (mobile phones) from connecting to this module. The initial password of the module is 000000 (ASCII). In this case, the APP does not need to input the password. It is considered password less. Any mobile device installing the specified APP can connect the module. APP can set a new password (not all 0) and save it. If the new password (not all 0) is set, the anti-hijacking password will be enabled. After APP connects this module, it must input the new password once to the module within 20 seconds, otherwise the module will disconnect. Before APP submits the correct password to the module, no write operation can be performed in the service channel except submitting the password. If users want to restore the password, they need to reset the module first. For the security, the module does not provide password read operation, and the memory of password is responsible for by APP. The protocol provides a password channel to submit, modify and cancel the password. It also provides the password event notification service to inform the

result of the APP operation, including correct password, wrong password, successful password modification, and cancellation of password use.

Eigenvalue UUID	Executable Operation	Bytes	Default	Remark
FFC1 (handle: 0x0045)	write (saved on power failure)	12	"123456123456"(ASCII)	Submit the current password 123456, the new password and old password must be consistent
			"123456888888"(ASCII)	Update the old password 123456 to the new password 888888. The old password must be correct.
			"888888000000"(ASCII)	Cancel the password. Update the new password to 000000. The old password must be correct.
FFC2 (handle: 0x0048)	notify	1	0 (PWD_RIGHT_EVENT)	Submit the password correctly
			1 (PWD_ERROR_EVENT)	Submit the password error

			2 (PWD_UPDATED_EVENT)	Update the password successfully.
			3 (PWD_CANCEL_EVENT)	Cancel the password

Table 4. Key Data Service

Note:

1. The password structure is 12 bytes ASCII code, the red part is the current password, and the black part is the new password.
2. The current password is "000000" by default before it is updated by APP.
3. By opening the notification EN of channel FFC2, a notification of the execution result of the password operation will be generated in this channel.
4. When APP submits the password "123456123456", the new password is the same as the current password, APP will get the "notify: 0 (PWD_RIGHT_EVENT)" in the FFC2 channel to indicate that the password submitted is correct;
5. When the password submitted by APP (red part) is not same with the current password, such as: "**123455**xxxxxx ", no matter what the value of the X part, APP will get the "notify: 1 (PWD_ERROR_EVENT)" in the FFC2 channel to indicate that the password submitted is not correct.
6. When APP submits the password "1234568888", the new password is "888888" and the current password is "123456", APP will get the "notify: 2

(PWD_UPDATED_EVENT)” in the FFC2 channel to indicate that the password has been successfully updated.

- When APP submits the password "888888000000" and the new password is updated to all 0, it means that the password is cancelled. APP will get the “notify: 3 (PWD_CANCEL_EVENT)” in the FFC2 channel.

10.3 Module Parameter Setting 【Service UUID : 0xFF90】

Eigenvalue UUID	Executable Operation	Saved on power failure	Bytes	Default	Remark
FF91 (handle: 0x0062)	Read/write	Yes	16	Tv232u-xxxxxxx (ASCII String with Ending Character)	Device name, xxxxxxxx is the last four bytes of the physical address
FF92 (handle: 0x0065)	Read/write	No	1	1	Bluetooth Communication Connection Interval : 0 : 20ms 1 : 30ms 2 : 50ms 3 : 100ms 4 : 200ms 5 : 300ms

					<p>6 : 400ms</p> <p>7 : 500ms</p> <p>8 : 1000ms</p> <p>9 : 2000ms</p>
FF93 (handle: 0x0068)	Read/write	Yes	1	5	<p>Set the Serial Port Baud Rate :</p> <p>0 : 4800 bps</p> <p>1 : 9600 bps</p> <p>2 : 19200 bps</p> <p>3 : 38400 bps</p> <p>4 : 57600 bps</p> <p>5 : 115200 bps</p>
FF94 (handle: 0x006B)	write	-	1	None	<p>Remote Reset and Recovery Control Channel:</p> <p>Remote Reset Control:</p> <p>Write 0x55 to reset the module.</p> <p>Remote Light Recovery Control:</p> <p>Write 0x35 to restore the module lightly (only restore the user data) and reset.</p> <p>Remote Deep Recovery Control:</p> <p>Write 0x36 to restore the module</p>

					deeply (let all parameters of module return to factory settings) and reset.
FF95 (handle: 0x006E)	Read/write	Yes	1	0	Set the advertisement period: 0 : 200 ms 1 : 500 ms 2 : 1000 ms 3 : 1500 ms 4 : 2000 ms 5 : 2500 ms 6 : 3000 ms 7 : 4000 ms 8 : 5000 ms
FF96 (handle: 0x0071)	Read/write	Yes	2	0x0000	Set the product identification code.
FF97 (handle: 0x0074)	Read/write	No	1	1	Set the Tx power : 0 : +4 dBm 1 : 0 dBm 2 : -6 dBm 3 : -23 dBm

FF98 (handle: 0x0077)	Read/write	Yes	16	Default advertisement content (see the chapter of <i>Advertisement Data Setting</i>)	Set the custom advertisement data: The custom advertisement data length is $0 < n \leq 16$
FF99 (handle: 0x007A)	write	-	1	None	Reserve
FF9A (handle: 0x007D)	Read/write	是	1	None	Reserve

Table 5. Parameter Setting Service

Module Information Configuration Channel Description:

FF91 is the device name setting channel

Users can access and set the module name by reading and writing operation in the channel. The name length L must be $0 < L < 17$. It is recommended to end with a terminator ('`\0`') . The default is "Tv2vvv-xxxxxxx\0"(16 bytes), "vvv" is the firmware version, and "xxxxxxx" is the last four bytes of the MAC address.

FF92 is the module connection interval setting channel

Users can set the connection interval between the mobile device and module by writing operation in the channel. In this way, users can flexibly control the device power consumption and data throughput. In order to improve the connection speed, the connection interval parameters are not saved, and the default is always 30ms after power-on.

FF93 is the module serial port baud rate setting channel

Users can set the universal serial baud rate of the module by reading and writing operation in the channel. The new baud rate is activated after 2 seconds. The parameter is saved on power failure. The default factory setting is 5(115200 bps).

FF94 is the remote reset recovery control channel

By writing different values, different control functions can be realized.

1. Write 0x55 to reset the module by software.
2. Write 0x35 to restore the module lightly. The anti-hijacking password will be restored to the factory settings, and then the module will be reset.
3. Write 0x36 to restore the module deeply. All system parameters will be restored to the factory setting, and then the module will be reset.

FF95 is the module advertisement period setting channel

Users can set the advertisement period of the module by reading and writing operation in the channel. The parameter is saved on power failure. The default

setting is 0 (200ms).

FF96 is the module product identification code setting channel

Users can set the module identification code by reading and writing operation in the channel. APP can filter or connect the specified product through this ID code. This parameter is saved on power failure. The default factory setting is 0x0000.

FF97 is the module Tx power setting channel

Users can set the Tx power of the module by writing operation in the channel. This parameter is not saved on power failure. The default factory setting is 1 (0 dBm).

FF98 is the modular advertisement content setting channel

Users can customize the advertisement data of the module by writing operation in the channel. This parameter is saved on power failure. When the data is all 0 (16 bytes), it is considered that the default advertisement data is used instead of the custom advertisement. See the chapter of *Advertisement Data Settings* for details.

10.4 OTA Service 【 Service UUID: 0x5833ff01-9b8b-5191-6142-22a 4536ef123】

Eigenvalue UUID	Executable Operation	Bytes	Default	Remark
0x5833ff02-9b8b-5191-6142-22a 4536ef123	Write	20	NULL	Firmware
0x5833ff03-9b8b-5191-6142-22a 4536ef123	Notify	20	NULL	Response

Table 6. OTA Service

10.5 Device Information 【Service UUID: 0x180A】

Eigenvalue UUID	Executable Operation	Bytes	Default	Remark
2A23 (handle:0x0003)	Read	8	xxxxxx0000xxxxxx (Hex)	System ID, XXXXXXXXXXXX is the physical address of the module chip, low bytes are in front
2A26 (handle:0x0005)	Read	7	v2.32u (ASCII)	Module Software Version No.

Table 7. Device Information Service

Module Information Read Channel Description:

- 2A23 is the module information read channel. Users can get the module ID by reading operation in the channel. The format is xxxxxx0000xxxxxxx. “xx” is the physical MAC address of the module chip, six bytes, low bytes in front.
- 2A26 is the module software version number reading channel. Users can get the module software version by reading operation in the channel. The format is Vx.xx. “x.xx” is the firmware version number.

Additional Information

RF Specification:

Function	Operation Frequency	Max RF Output Power:	Limit
BLE	2402MHz–2480MHz	7.16dBm	10dBm.

DECLARATION OF CONFORMITY

Hereby, Shenzhen HOPE Microelectronics Co., Ltd. declares that this Bluetooth Low Energy (BLE) 5.0 Data Pass-through Module product is in compliance with the essential requirements and other relevant provisions of Directive 2014/53/EU. A copy of the Declaration of Conformity can be found at Website: www.hoperf.com

Testing standards:

(Draft) ETSI EN 301 489-1 V2.2.1 (2019-03)
(Draft) ETSI EN 301 489-17 V3.2.0 (2017-03)
EN 55032:2015;
EN 55035:2017;
EN 61000-3-2:2014;
EN 61000-3-3:2013;
ETSI EN 300 328 V2.1.1 (2016-11);
EN 62479:2010

Manufacturer's Name: Shenzhen HOPE Microelectronics Co., Ltd.

Bluetooth Low Energy (BLE) 5.0 Data Pass-through Module

Model Number: HM-BT4502, HM-BT4502B, HM-BT4502C, HM-BT4502D, HM-BT4502E, HM-BT4502F

Operating Temperature: -40°C ~ +125°C (BLE Chip Only)

1. The device complies with RF specifications when the device is used at 20cm from your body.
2. This product can be used across all EU member states.

Care for the environment! Must not be discarded with household waste!



This module is intended for OEM integrator. The OEM integrator is still responsible for the FCC compliance requirement of the end product which integrates this module. 20cm minimum distance has to be able to be maintained between the antenna and the users for the host this module is integrated into. Under such configuration, the FCC radiation exposure limits set forth for an population/uncontrolled environment can be satisfied. Antenna used should be limited to same type with equal or lesser antenna gain. According to FCC Part 15 Subpart C Section 15.212, the radio elements of the modular transmitter must have their own power supply. However, due to there is no power supply for this BLE Module, this module is granted as a Limited Modular Approval. When this BLE Module is installed into the end product, a Class II Permissive Change or a New FCC ID submission is required to ensure the full compliance of FCC relevant requirements.

FCC Caution:

Any changes or modifications not expressly approved by the party responsible for compliance could void the user's authority to operate this equipment.

This device complies with Part 15 of the FCC Rules. Operation is subject to the following two conditions:

- (1) This device may not cause harmful interference, and
- (2) this device must accept any interference received, including interference

that may cause undesired operation.

This device and its antenna(s) must not be co-located or operating in conjunction with any other antenna or transmitter. 15.105 Information to the user. (b) For a Class B digital device or peripheral, the instructions furnished the user shall include the following or similar statement, placed in a prominent location in the text of the manual:

Note: This equipment has been tested and found to comply with the limits for a Class B digital device, pursuant to part 15 of the FCC Rules. These limits are designed to provide reasonable protection against harmful interference in a residential installation. This equipment generates, uses and can radiate radio frequency energy and, if not installed and used in accordance with the instructions, may cause harmful interference to radio communications.

However, there is no guarantee that interference will not occur in a particular installation. If this equipment does cause harmful interference to radio or television reception, which can be determined by turning the equipment off and on, the user is encouraged to try to correct the interference by one or more of the following measures:

- Reorient or relocate the receiving antenna.
- Increase the separation between the equipment and receiver.
- Connect the equipment into an outlet on a circuit different from that to

which the receiver is connected.

—Consult the dealer or an experienced radio/TV technician for help.

1. This LMA does not have RF shielding and is tested and approved as standalone configuration, additional evaluation may be required for any system integrated this radio module.
2. The modular transmitter doesn't have its own power supply regulation, it's provided by host.

Radiation Exposure Statement: This equipment complies with FCC radiation exposure limits set forth for an uncontrolled environment.

This transmitter must not be co-located or operating in conjunction with any other antenna or transmitter.

The availability of some specific channels and/or operational frequency bands are country dependent and are firmware programmed at the factory to match the intended destination. The firmware setting is not accessible by the end user. The final end product must be labelled in a visible area with the following:
"Contains Transmitter Module 2ASEO-HM-BT4502"

IC Caution:

This device complies with Industry Canada license-exempt RSS standard(s).

Operation is subject to the following two conditions:

- (1) This device may not cause interference,

(2) This device must accept any interference, including interference that may cause undesired operation of the device.

Le présent appareil est conforme aux CNR d'Industrie Canada applicables aux appareils radio exempts de licence. L'exploitation est autorisée aux deux conditions suivantes: (1) l'appareil ne doit pas produire de brouillage, et (2) l'utilisateur de l'appareil doit accepter tout brouillage radioélectrique subi, même si le brouillage est susceptible d'en compromettre le fonctionnement.

HOPE MICROELECTRONICS CO., LTD.

Add: 2/F, Building 3, Pingshan Private Enterprise
Science & Technology Park, Xili Town, Nanshan
District, Shenzhen, Guangdong, China 518057

Tel: 86-755-82973805

Fax: 86-755-82973550

Email: sales@hoperf.com

Website: <http://www.hoperf.com>

This document may contain preliminary information and is subject to change by Hope Microelectronics without notice. Hope Microelectronics assumes no responsibility or liability for any use of the information contained herein. Nothing in this document shall operate as an express or implied license or indemnity under the intellectual property rights of Hope Microelectronics or third parties. The products described in this document are not intended for use in implantation or other direct life support applications where malfunction may result in the direct physical harm or injury to persons. NO WARRANTIES OF ANY KIND, INCLUDING, BUT NOT LIMITED TO, THE IMPLIED WARRANTIES OF MERCHANTABILITY OR FITNESS FOR A PARTICULAR PURPOSE, ARE OFFERED IN THIS DOCUMENT.

©2006, HOPE MICROELECTRONICS CO., LTD. All rights reserved.