



HESTORE.HU

elektronikai alkatrész áruház

EN: This Datasheet is presented by the manufacturer.

Please visit our website for pricing and availability at www.hestore.hu.



IR Emitter and Detector Product Data Sheet

LTR-3208E

Spec No.: DS-50-92-0068

Effective Date: 05/03/2000

Revision: A

LITE-ON DCC

RELEASE

BNS-OD-FC001/A4

FEATURES

- * WIDE RANGE OF COLLECTOR CURRENT
- * THE LENS IS FOR HIGH SENSITIVITY
- * LOW COST PLASTIC PACKAGE
- * THE LTR-3208E IS A SPECIAL DARK PLASTIC PACKAGE THAT CUT THE VISIBLE LIGHT AND SUITABLE FOR THE DETECTORS OF INFRARED APPLICATIONS

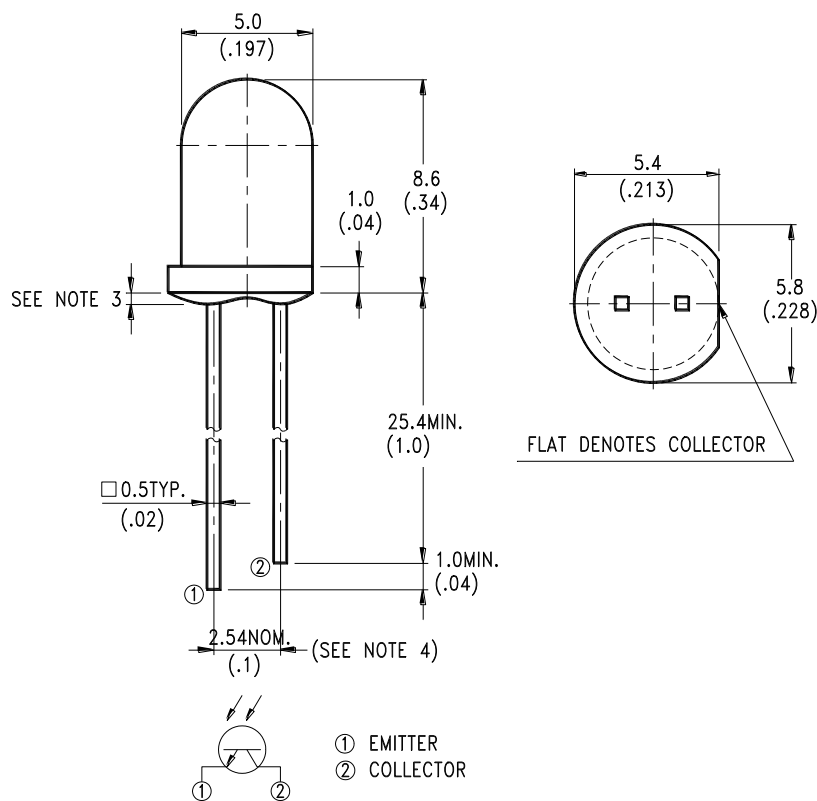
PACKAGE DIMENSIONS**NOTES:**

1. All dimensions are in millimeters (inches).
2. Tolerance is $\pm 0.25\text{mm} (.010\text{'})$ unless otherwise noted.
3. Protruded resin under flange is 1.5mm (.059") max.
4. Lead spacing is measured where the leads emerge from the package.
5. Specifications are subject to change without notice.



ABSOLUTE MAXIMUM RATINGS AT TA=25°C

PARAMETER	MAXIMUM RATING	UNIT
Power Dissipation	100	mW
Collector-Emitter Voltage	30	V
Emitter-Collector Voltage	5	V
Operating Temperature Range	-40°C to + 85°C	
Storage Temperature Range	-55°C to + 100°C	
Lead Soldering Temperature [1.6mm(.063") From Body]	260°C for 5 Seconds	

ELECTRICAL / OPTICAL CHARACTERISTICS AT TA=25°C

PARAMETER	SYMBOL	MIN.	TYP.	MAX	UNIT	TEST CONDITION	BIN NO.
Collector-Emitter Breakdown Voltage	$V_{(BR)CEO}$	30			V	$I_C = 1mA$ $E_e = 0mW/cm^2$	
Emitter-Collector Breakdown Voltage	$V_{(BR)ECO}$	5			V	$I_E = 100 \mu A$ $E_e = 0mW/cm^2$	
Collector Emitter Saturation Voltage	$V_{CE(SAT)}$		0.1	0.4	V	$I_C = 100 \mu A$ $E_e = 1mW/cm^2$	
Rise Time	T_r		10		μs	$V_{CC} = 5V$ $I_C = 1mA$ $R_L = 1K\Omega$	
Fall Time	T_f		15		μs		
Collector Dark Current	I_{CEO}			100	nA	$V_{CE} = 10V$ $E_e = 0mW/cm^2$	
On State Collector Current	$I_{C(ON)}$	0.64		1.68	mA	$V_{CE} = 5V$ $E_e = 1mW/cm^2$ $\lambda = 940nm$	BIN A
		1.12		2.16			BIN B
		1.44		2.64			BIN C
		1.76		3.12			BIN D
		2.08		3.60			BIN E
		2.40					BIN F

TYPICAL ELECTRICAL / OPTICAL CHARACTERISTICS CURVES

(25°C Ambient Temperature Unless Otherwise Noted)

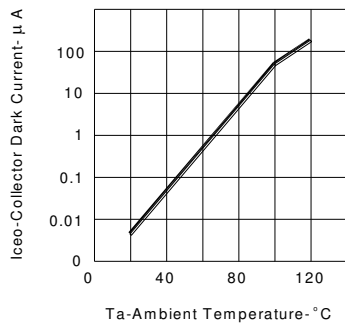

FIG.1 COLLECTOR DARK CURRENT VS AMBIENT TEMPERATURE

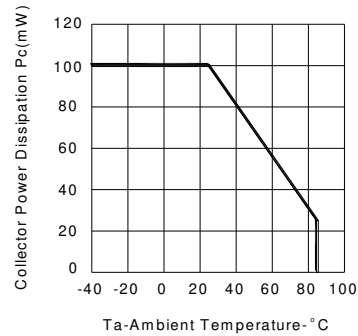

FIG.2 COLLECTOR POWER DISSIPATION VS AMBIENT TEMPERATURE

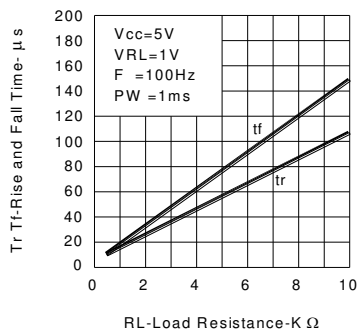

FIG.3 RISE AND FALL TIME VS LOAD RESISTANCE

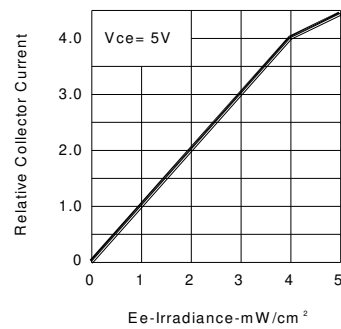

FIG.4 RELATIVE COLLECTOR CURRENT VS IRRADIANCE

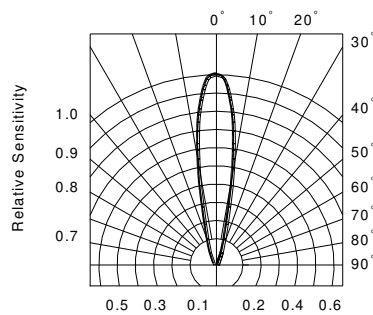

FIG.5 SENSITIVITY DIAGRAM