



HESTORE.HU

elektronikai alkatrész áruház

EN: This Datasheet is presented by the manufacturer.

Please visit our website for pricing and availability at www.hestore.hu.

FEATURES

- Fully compatible with the ISO 11898 standard
- Thermally protected
- ±70V BUS protection
- Driver (TXD) and standby bus (BUS) dominant timeout function
- Low-power standby mode with wake-up function
- SIT1042AT/3 can be interfaced directly to microcontrollers with supply voltages from 3V to 5V
- Undervoltage protection on VCC and VIO power supply pins
- Timing guaranteed for data rates up to 5 Mbit/s in the (CAN FD) fast phase
- The typical loop delay from TXD to RXD is less than 100ns
- Very low ElectroMagnetic Emission (EME)
- Unpowered nodes do not interfere with the bus
- Provide DFN3*3-8, small outline, leadless package

PRODUCT APPEARANCE

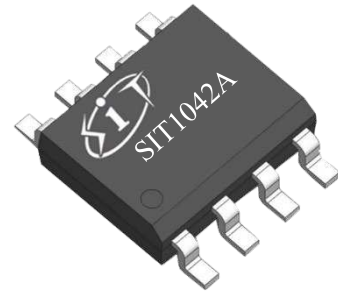

Provide Green and Environmentally
Friendly Lead-free package

DESCRIPTION

SIT1042A is an interface chip used between the CAN protocol controller and the physical bus. It can be used for in-vehicle, industrial control and other fields. It supports 5Mbps (CAN FD), and has ability to perform differential signal transmission between bus and the CAN protocol controller.

The SIT1042A is an upgraded version of the SIT1042 with improved bus signal symmetry and lower electromagnetic radiation performance. In addition, the SIT1042A is fully compatible with SIT1042.

PARAMETER	SYMBOL	CONDITION	MIN.	MAX.	UNIT
Supply voltage	VCC		4.5	5.5	V
Maximum transmission rate	1/t _{bit}	Non-return to zero code	5		Mbaud
CANH/CANL input or output voltage	V _{can}		-70	+70	V
Bus differential voltage	V _{diff}		1.5	3.0	V
Virtual junction temperature	T _j		-40	150	°C

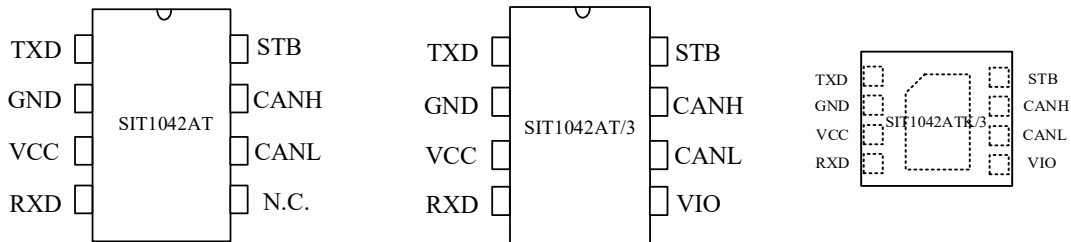
PIN CONFIGURATION

PIN DESCRIPTION

PIN	SYMBOL	DESCRIPTION
1	TXD	transmit data input
2	GND	ground
3	VCC	supply voltage
4	RXD	receive data output; reads out data from the bus lines
5	VIO	transceiver I/O level conversion power supply voltage (SIT1042AT/3 version)
5	N.C.	no connection (SIT1042AT version)
6	CANL	LOW-level CAN-bus line
7	CANH	HIGH-level CAN-bus line
8	STB	standby mode control input, low level is high speed mode

LIMITING VALUES

PARAMETER	SYMBOL	VALUE	UNIT
Supply voltage	VCC	-0.3~7	V
MCU side port	TXD, RXD, STB, VIO	-0.3~7	V
Bus side input voltage	CANL, CANH	-70~70	V
Bus differential breakdown voltage	$V_{CANH-CANL}$	-27~27	V
Storage temperature	T_{stg}	-55~150	°C
Virtual junction temperature	T_j	-40~150	°C

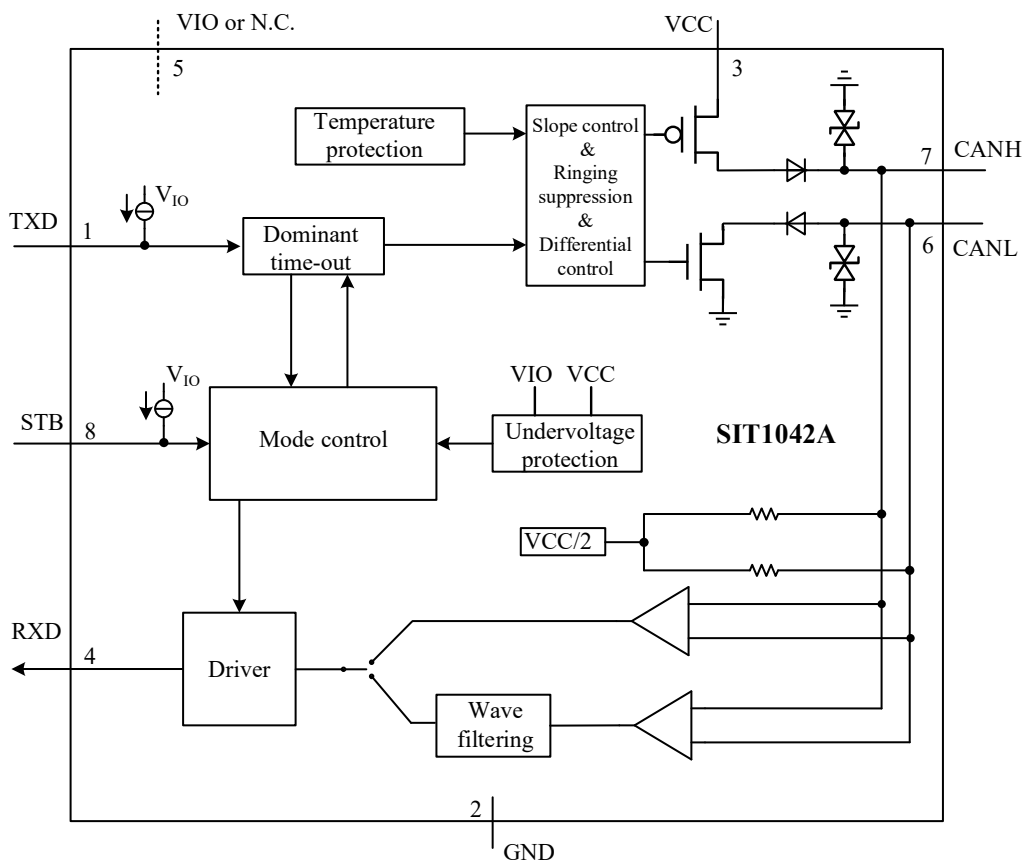
The maximum limit parameters mean that exceeding these values may cause irreversible damage to the device. Under these conditions, it is not conducive to the normal operation of the device. The continuous operation of the device at the maximum allowable rating may affect the reliability of the device. The reference point for all voltages is ground.

INTERNAL CIRCUIT BLOCK DIAGRAM

DRIVER ELECTRICAL CHARACTERISTICS

PARAMETER	SYMBOL	CONDITION	MIN.	TYP.	MAX.	UNIT
CANH dominant output voltage	$V_{OH(D)}$	Normal mode, TXD=0V, $R_L=50\Omega$ to 65Ω	2.75	3.5	4.5	V
CANL dominant output voltage	$V_{OL(D)}$		0.5	1.5	2.25	V
Bus dominant differential output voltage	$V_{OD(D)}$	Normal mode, TXD=0V, $R_L=50\Omega$ to 65Ω	1.5		3	V
		Normal mode, TXD=0V, $R_L=45\Omega$ to 70Ω	1.4		3.3	V
		Normal mode, TXD=0V, $R_L=2240\Omega$	1.5		5	V
Bus recessive output voltage	$V_{O(R)}$	Normal mode, TXD=VIO, No load	2	0.5V _{CC}	3	V
Bus recessive differential output voltage	$V_{OD(R)}$	Normal mode, TXD=VIO, No load	-500		50	mV
Bus output voltage (Bus is biased to ground)	$V_{O(S)}$	Standby mode, No load	-0.1		0.1	V
Bus differential output voltage (Bus is biased to ground)	$V_{OD(S)}$	Standby mode, No load	-0.2		0.2	V
Transmitter dominant voltage symmetry	$V_{dom(TX)sym}$	$V_{dom(TX)sym}=V_{CC}-$ CANH - CANL	-400		400	mV
Transmitter voltage symmetry	V_{TXsym}	$V_{TXsym}=CANH +$ CANL, $R_L=60\Omega$, $C_{SPLIT}=4.7nF$, $f_{TXD}=250kHz$, 1MHz, 2MHz Fig 5	0.9V _{CC}		1.1V _{CC}	V
Dominant-recessive common-mode output voltage difference	$V_{cm(step)}$	Fig 3 , Fig 5	-150		150	mV

PARAMETER	SYMBOL	CONDITION	MIN.	TYP.	MAX.	UNIT
Dominant-recessive common-mode peak-to-peak	$V_{cm(p-p)}$	Fig 3 , Fig 5	-300		300	mV
Dominant short-circuit output current	$I_{O(SC)DOM}$	Normal mode, TXD=0V, CANH=-15V to 40V	-100	-70	-40	mA
		Normal mode, TXD=0V, CANL=-15V to 40V	40	70	100	mA
Recessive short-circuit output current	$I_{O(SC)REC}$	Normal mode, TXD=VIO, CANH=CANL=-27V to 32V	-3		3	mA

Unless otherwise stated, all typical values are measured at 25°C, supply voltage VCC=5V, VIO=5V (if applicable), $R_L=60\Omega$.

DRIVER SWITCHING CHARACTERISTICS

PARAMETER	SYMBOL	CONDITION	MIN.	TYP.	MAX.	UNIT
Propagation delay time, low-to-high level output	$t_{d(TXD-busdom)}$	Normal mode, Fig 1 , Fig 4		45		ns
Propagation delay time, high-to-low level output	$t_{d(TXD-busrec)}$	Normal mode, Fig 1 , Fig 4		55		ns
Differential output signal rise time	$t_{r(BUS)}$			45		ns
Differential output signal fall time	$t_{f(BUS)}$			45		ns

Unless otherwise stated, all typical values are measured at 25°C, supply voltage VCC=5V, VIO=5V (if applicable), $R_L=60\Omega$.

RECEIVER ELECTRICAL CHARACTERISTICS

PARAMETER	SYMBOL	CONDITION	MIN.	TYP.	MAX.	UNIT
Receiver threshold voltage	$V_{th(RX)dif}$	Normal mode, $-30V < V_{CM} < 30V$	0.5		0.9	V
		Normal mode, $-12V < V_{CM} < 12V$	0.4		1.15	V
Receiver threshold voltage hysteresis range	$V_{hys(RX)dif}$	Normal mode, $-30V < V_{CM} < 30V$	50	120	400	mV
Receiver recessive voltage range	$V_{rec(RX)}$	Normal mode, $-30V < V_{CM} < 30V$	-3		0.5	V
		Standby mode, $-12V < V_{CM} < 12V$	-3		0.4	V
Receiver dominant voltage range	$V_{dom(RX)}$	Normal mode, $-30V < V_{CM} < 30V$	0.9		8	V
		Standby mode, $-12V < V_{CM} < 12V$	1.15		8	V
Bus leakage current	I_L	$V_{CC} = V_{IO} = 0V$, CANH= CANL=5V	-10		10	μA
CANH, CANL input resistance	R_{IN}	$-2V \leq CANH \leq 7V$ $-2V \leq CANL \leq 7V$	9	15	28	k Ω
CANH, CANL differential-input resistance	R_{ID}	$-2V \leq CANH \leq 7V$ $-2V \leq CANL \leq 7V$	19	30	52	k Ω
CANH, CANL input resistance mismatch	ΔR_{IN}	$0V \leq CANH \leq 5V$ $0V \leq CANL \leq 5V$	-2		2	%
CANH, CANL input capacitance to ground	C_{IN}	TXD=VIO		24		pF
CANH, CANL differential-input capacitance	C_{ID}	TXD=VIO		12		pF
Bus slew rate	SR	Bus differential voltage dominant to recessive edge			70	V/ μs

Unless otherwise stated, all typical values are measured at 25°C, supply voltage $V_{CC}=5V$, $V_{IO}=5V$ (if applicable), $R_L=60\Omega$.

RECEIVER SWITCHING CHARACTERISTICS

PARAMETER	SYMBOL	CONDITION	MIN.	TYP.	MAX.	UNIT
Propagation delay time, low-to-high level output	$t_{d(\text{busdom-RXD})}$	Normal mode, Fig 1, Fig 4		45		ns
Propagation delay time, high-to-low level output	$t_{d(\text{busrec-RXD})}$	Normal mode, Fig 1, Fig 4		45		ns
RXD signal rise time	$t_{r(\text{RXD})}$			8		ns
RXD signal fall time	$t_{f(\text{RXD})}$			8		ns

Unless otherwise stated, all typical values are measured at 25°C, supply voltage VCC=5V, VIO=5V (if applicable), R_L=60Ω.

DEVICE SWITCHING CHARACTERISTICS

PARAMETER	SYMBOL	CONDITION	MIN.	TYP.	MAX.	UNIT
Loop delay 1, TXD falling edge to RXD falling edge	t_{loop1}	Normal mode, Fig 1, Fig 4	40		160	ns
Loop delay 2, TXD rising edge to RXD rising edge	t_{loop2}	Normal mode, Fig 1, Fig 4	40		175	ns
Bit time of BUS output pin	$t_{\text{bit}(\text{BUS})}$	$t_{\text{bit}(\text{TXD})}=500\text{ns}$	435		530	ns
		$t_{\text{bit}(\text{TXD})}=200\text{ns}$	155		210	ns
Bit time of RXD output pin	$t_{\text{bit}(\text{RXD})}$	$t_{\text{bit}(\text{TXD})}=500\text{ns}$	400		550	ns
		$t_{\text{bit}(\text{TXD})}=200\text{ns}$	120		220	ns
Time difference between BUS and RXD output bits	Δt_{rec}	$\Delta t_{\text{rec}}=t_{\text{bit}(\text{RXD})}-t_{\text{bit}(\text{BUS});}$ $t_{\text{bit}(\text{TXD})}=500\text{ns}$	-65		40	ns
		$\Delta t_{\text{rec}}=t_{\text{bit}(\text{RXD})}-t_{\text{bit}(\text{BUS});}$ $t_{\text{bit}(\text{TXD})}=200\text{ns}$	-45		15	ns
TXD dominant timeout	$t_{\text{dom_TXD}}$		0.8	2	4	ms
BUS dominant timeout	$t_{\text{dom_BUS}}$		0.8	2	4	ms
Enable time from standby mode to normal mode	t_{EN}				10	μs

PARAMETER	SYMBOL	CONDITION	MIN.	TYP.	MAX.	UNIT
Wake-up time of BUS	t_{WAKE}		0.5		1.8	μs

Unless otherwise stated, all typical values are measured at 25°C, supply voltage VCC=5V, VIO=5V (if applicable), $R_L=60\Omega$.

TXD PIN CHARACTERISTICS

PARAMETER	SYMBOL	CONDITION	MIN.	TYP.	MAX.	UNIT
HIGH-level input current	$I_{IH}(TXD)$	TXD=VIO	-5		5	μA
LOW-level input current	$I_{IL}(TXD)$	TXD=0V	-260	-150	-30	μA
Leakage current of TXD without power	$I_{O(off)}$	VCC=VIO=0V, TXD=5.5V	-1		1	μA
HIGH-level input voltage	V_{IH}	SIT1042AT/3	0.7VIO		VIO+0.3	V
LOW-level input voltage	V_{IL}	SIT1042AT/3	-0.3		0.3VIO	V
HIGH-level input voltage	V_{IH}	SIT1042AT	2		VCC+0.3	V
LOW-level input voltage	V_{IL}	SIT1042AT	-0.3		0.8	V
Open voltage on TXD pin	TXD _O		H			logic

Unless otherwise stated, all typical values are measured at 25°C, supply voltage VCC=5V, VIO=5V (if applicable), $R_L=60\Omega$.

STB PIN CHARACTERISTICS

PARAMETER	SYMBOL	CONDITION	MIN.	TYP.	MAX.	UNIT
HIGH-level input current	$I_{IH}(STB)$	STB=VIO	-2		2	μA
LOW-level input current	$I_{IL}(STB)$	STB=0V	-20		-2	μA
Leakage current of STB without power	$I_{O(off)}$	VCC=VIO=0V, STB=5.5V	-1		1	μA
HIGH-level input voltage	V_{IH}	SIT1042AT/3	0.7VIO		VIO+0.3	V
LOW-level input voltage	V_{IL}	SIT1042AT/3	-0.3		0.3VIO	V

PARAMETER	SYMBOL	CONDITION	MIN.	TYP.	MAX.	UNIT
HIGH-level input voltage	V_{IH}	SIT1042AT	2		$V_{CC}+0.3$	V
LOW-level input voltage	V_{IL}	SIT1042AT	-0.3		0.8	V
Open voltage on STB pin	STB _o		H			logic

Unless otherwise stated, all typical values are measured at 25°C, supply voltage $V_{CC}=5V$, $V_{IO}=5V$ (if applicable), $R_L=60\Omega$.

RXD PIN CHARACTERISTICS

PARAMETER	SYMBOL	CONDITION	MIN.	TYP.	MAX.	UNIT
HIGH-level input current	$I_{OH}(RXD)$	$V_{IO}=V_{CC}$, $RXD=V_{IO}-0.4V$	-8	-3	-1	mA
LOW-level input current	$I_{OL}(RXD)$	$RXD=0.4V$, Bus dominant	2	5	12	mA
Leakage current of RXD without power	$I_{o(off)}$	$V_{CC}=V_{IO}=0V$, $RXD=5.5V$	-1		1	μA

Unless otherwise stated, all typical values are measured at 25°C, supply voltage $V_{CC}=5V$, $V_{IO}=5V$ (if applicable), $R_L=60\Omega$.

SUPPLY CURRENT

PARAMETER	SYMBOL	CONDITION	MIN.	TYP.	MAX.	UNIT	
VCC supply current	I_{CC_D}	Normal mode, dominant		45	70	mA	
	I_{CC_R}	Normal mode, recessive		5	10	mA	
	I_{CC_STB}	Standby mode, $STB=TXD=V_{IO}$, (SIT1042AT/3)			0.5	5	μA
		Standby mode, $STB=TXD=V_{CC}$, (SIT1042AT)			12	20	μA
VIO supply current	I_{IO_D}	Normal mode, dominant		170	300	μA	
VIO supply current	I_{IO_R}	Normal mode, recessive		15	30	μA	

PARAMETER	SYMBOL	CONDITION	MIN.	TYP.	MAX.	UNIT
VIO supply current	I_{IO_STB}	Standby mode, STB=TXD=VIO		10	17	μA

Unless otherwise stated, all typical values are measured at 25°C, supply voltage VCC=5V, VIO=5V (if applicable), $R_L=60\Omega$.

OVER TEMPERATURE PROTECTION

PARAMETER	SYMBOL	CONDITION	MIN.	TYP.	MAX.	UNIT
Shutdown junction temperature	$T_{j(sd)}$			190		$^{\circ}\text{C}$

Unless otherwise stated, all typical values are measured at 25°C, supply voltage VCC=5V, VIO=5V (if applicable), $R_L=60\Omega$.

UNDERVOLTAGE PROTECTION

PARAMETER	SYMBOL	CONDITION	MIN.	TYP.	MAX.	UNIT
VCC undervoltage protection	V_{uvd_VCC}		3.7	4	4.3	V
VIO undervoltage protection	V_{uvd_VIO}		1.7	2	2.3	V

Unless otherwise stated, all typical values are measured at 25°C, supply voltage VCC=5V, VIO=5V (if applicable), $R_L=60\Omega$.

ESD PERFORMANCE

PARAMETER	SYMBOL	CONDITION	MIN.	TYP.	MAX.	UNIT
CAN bus pin contact discharge model (IEC)	V_{ESD_IEC}	IEC 61000-4-2: Contact discharge (CANH, CANL)	-4		+4	kV
Human body model (HBM)	V_{ESD_HBM}	All ports	-8		+8	kV
Charged device model (CDM)	V_{ESD_CDM}		-750		+750	V
Machine model (MM)	V_{ESD_MM}		-300		+300	V

FUNCTION TABLE
Table1. CAN TRANSCEIVER TRUTH TABLE

TXD ⁽¹⁾	STB ⁽¹⁾	CANH ⁽¹⁾	CANL ⁽¹⁾	BUS STATE	RXD ⁽¹⁾
L	L	H	L	Dominate	L
H or Open	L	0.5VCC	0.5VCC	Recessive	H
X	H or Open	GND	GND	Recessive	H

(1) H=high level; L=low level; X=irrelevant.

Table 2. RECEIVER FUNCTION TABLE

OPERATING MODE	$V_{ID}=CANH-CANL$	BUS STATE	RXD ⁽¹⁾
Normal mode	$V_{ID} \geq 0.9V$	Dominate	L
	$0.5 < V_{ID} < 0.9V$?	?
	$V_{ID} \leq 0.5V$	Recessive	H
Standby mode	$V_{ID} \geq 1.15V$	Dominate	L
	$0.4 < V_{ID} < 1.15V$?	?
	$V_{ID} \leq 0.4V$	Recessive	H

(1) H=high level; L=low level; ?=uncertain.

Table 3. UNDERVOLTAGE PROTECTION STATUS TABLE

VCC	VIO ⁽¹⁾	BUS STATE	BUS OUTPUT ⁽²⁾	RXD ⁽²⁾
$VCC > V_{uvd_VCC}$	$VIO > V_{uvd_VIO}$	Normal	According to STB and TXD	Follow the bus
$VCC < V_{uvd_VCC}$	$VIO > V_{uvd_VIO}$	Protected status	GND	H
$VCC > V_{uvd_VCC}$	$VIO < V_{uvd_VIO}$	Protected status	Z	H
$VCC < V_{uvd_VCC}$	$VIO < V_{uvd_VIO}$	Protected status	Z	H

(1) SIT1042AT/3 version only;

(2) H=high level; Z=high ohmic.

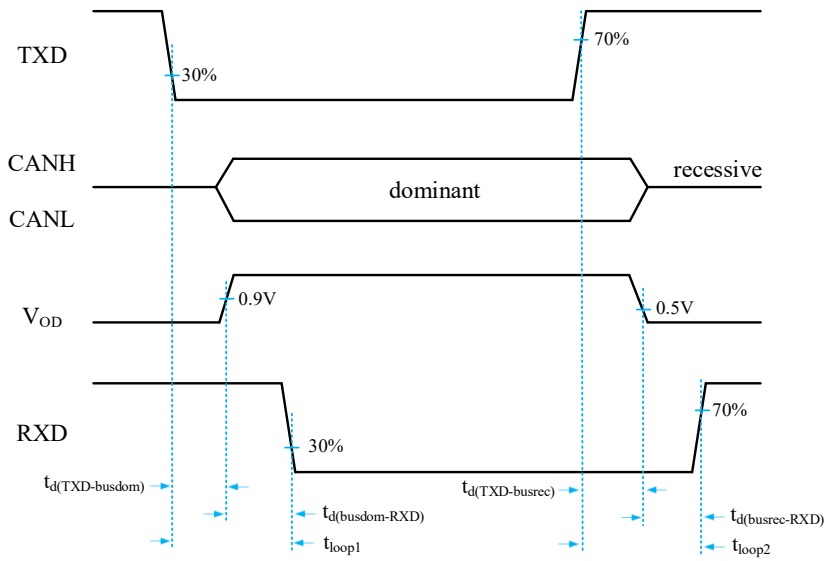
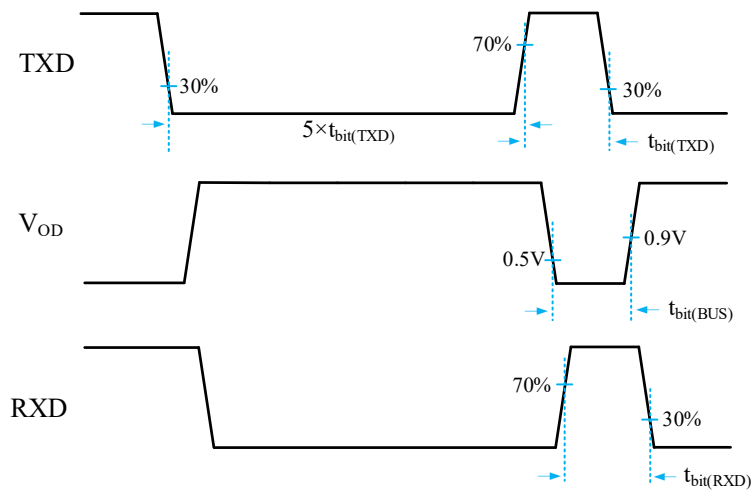
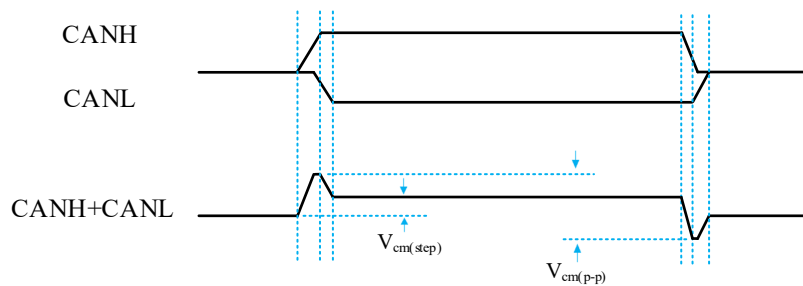
TIMING WAVEFORM

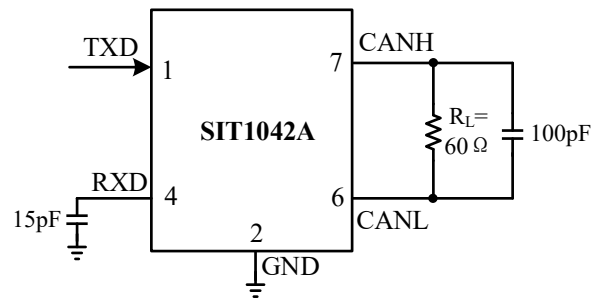
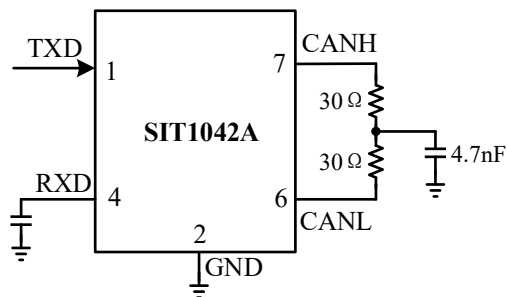
Fig 1 Transceiver transmission delay

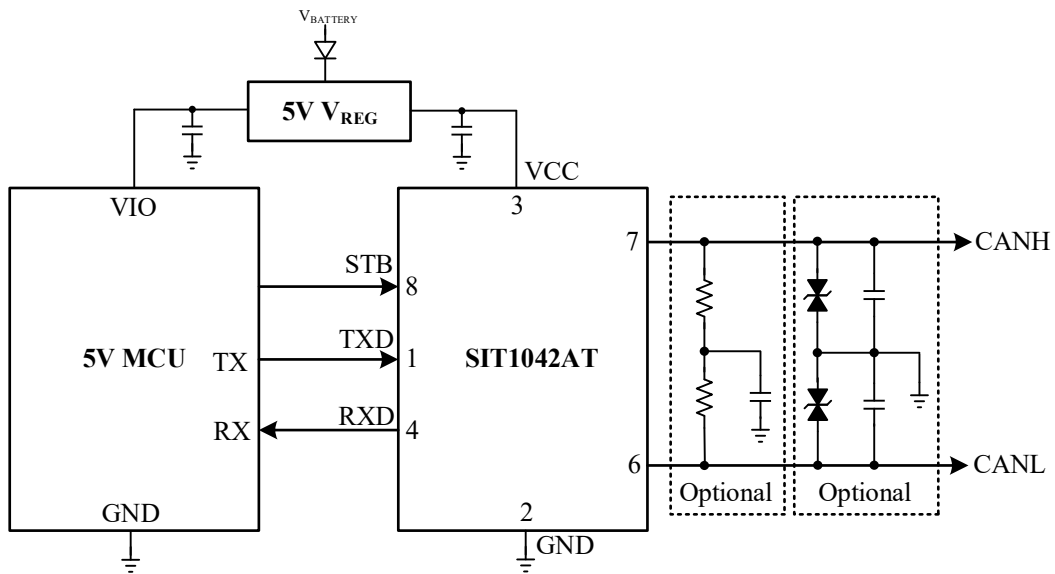
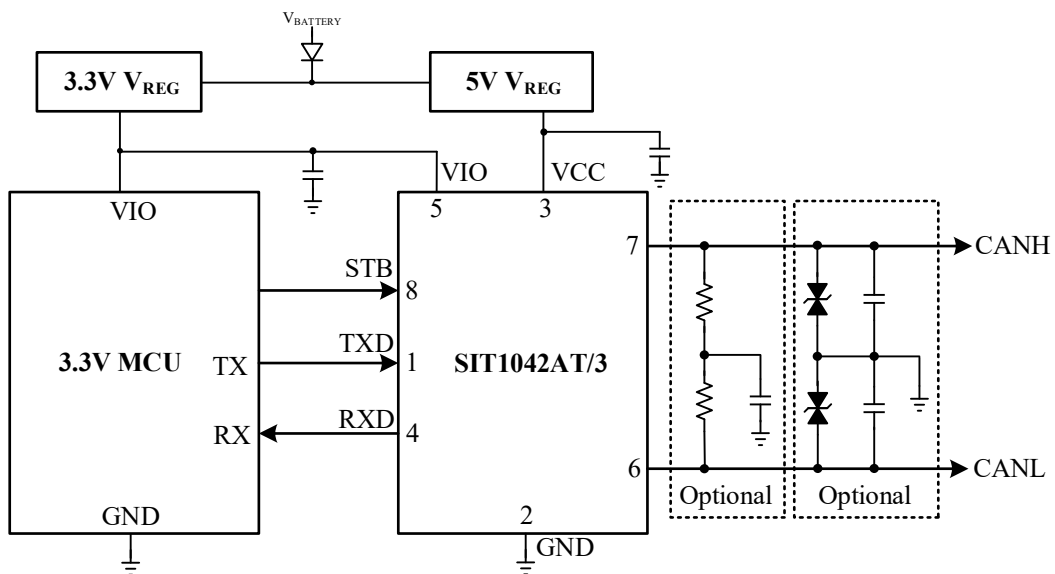
Fig 2 t_{bit} delay

Fig 3 Bus common-mode voltage (SAE 1939-14)

TEST CIRCUIT

Fig 4 Transceiver timing sequence test circuit

Fig 5 Transceiver bus symmetry test circuit

TYPICAL APPLICATION DIAGRAM

Fig 6 SIT1042AT and 5V MCU typical application diagram

Fig 7 SIT1042AT/3 and 3.3V MCU typical application diagram

ADDITIONAL DESCRIPTION**1 Sketch**

SIT1042A is an interface chip applied between the CAN protocol controller and the physical bus. It can be used for in-vehicle, industrial control and other fields. It supports 5Mbps flexible data rate (CAN FD) and has the ability to transmit differential signals between the bus and the CAN protocol controller. Fully compatible with ISO 11898 standard.

2 Short-circuit protection

A current-limiting circuit protects the transmitter output stage from damage caused by accidental short-circuit to either positive or negative supply voltage, although power dissipation increases during this fault condition.

3 Over temperature protection

The output drivers are protected against over-temperature conditions. If the virtual junction temperature exceeds the shutdown junction temperature $T_{j(sd)}$, the output drivers will be disabled until the virtual junction temperature becomes lower than $T_{j(sd)}$ and TXD becomes recessive again.

By including the TXD condition, the occurrence of output driver oscillation due to temperature drifts is avoided.

4 Undervoltage protection

The SIT1042A power supply pin has an undervoltage detection function, which can put the device in a protected mode. This protects the bus when VCC is lower than V_{uvd_VCC} or VIO is lower than V_{uvd_VIO} .

5 Control mode

The SIT1042A provides two modes of operation which are selectable via pin STB: High-speed mode and standby mode.

High-speed mode is normal working mode, by connecting STB to ground to set the SIT1042A to high-speed mode. In this mode the transceiver is able to transmit and receive data via the bus lines CANH and CANL. The differential receiver converts the analog data on the bus lines into digital data which is output to pin RXD via the multiplexer (MUX).

Set pin STB to high level to activate low power standby mode. CAN driver and receiver are turned off to save system power consumption. A high level on the pin STB activates this low-power receiver and wake-up filter, and pin RXD becomes low once the low-power differential comparator detects that the dominant bus level of the T_{WAKE} is exceeded. (In SIT1042AT/3, when the VCC is undervoltage or the VCC is open, the low-power receiver can still detect dominant and recessive level on the bus as long as the VIO is powered properly.)

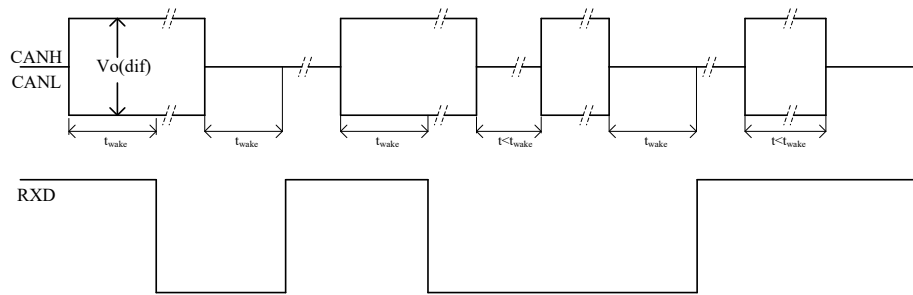
Fig 8 Wake-up timing

6 TXD dominant time-out function

A 'TXD dominant time-out' timer circuit prevents the bus lines from being driven to a permanent dominant state (blocking all network communication) if pin TXD is forced permanently LOW by a hardware and/or software application failure. The timer is triggered by a falling edge on pin TXD.

If the duration of the LOW level on pin TXD exceeds the internal timer value ($t_{\text{dom_TXD}}$), the transmitter is disabled, driving the bus lines into a recessive state. The timer is reset by a rising edge on pin TXD.

In standby mode, the pin RXD is forced to high if the bus becomes dominant and lasts longer than ($t_{\text{dom_BUS}}$), which can prevent permanent wakeup due to a short circuit in the bus or the failure of another node on the network. It can be reset when the bus changes from dominant to recessive.

SOP8 DIMENSIONS
PACKAGE SIZE

SYMBOL	MIN./mm	TYP./mm	MAX./mm
A	1.40	-	1.80
A1	0.10	-	0.25
A2	1.30	1.40	1.50
A3	0.60	0.65	0.70
b	0.38	-	0.51
D	4.80	4.90	5.00
E	5.80	6.00	6.20
E1	3.80	3.90	4.00
e	1.27BSC		
L	0.40	0.60	0.80
L1	1.05REF		
c	0.20	-	0.25
θ	0°	-	8°

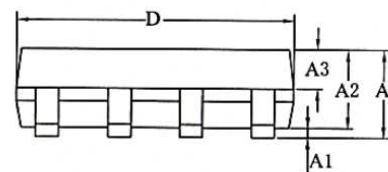
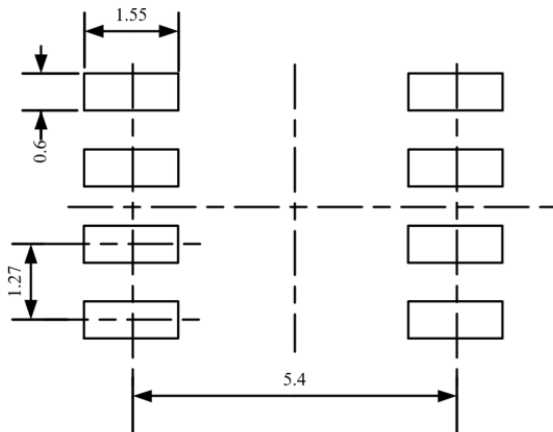
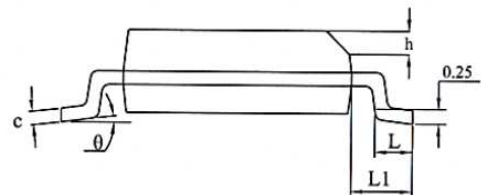
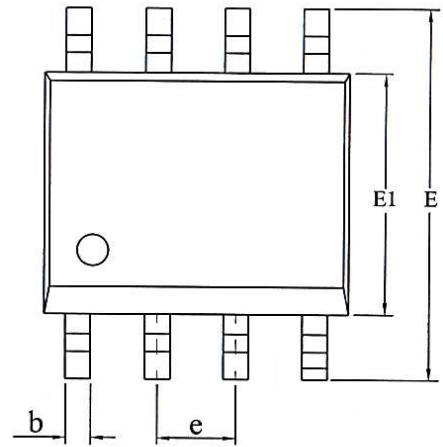

LAND PATTERN EXAMPLE (Unit: mm)

DFN3*3-8 DIMENSIONS
PACKAGE SIZE

SYMBOL	MIN/mm	TYP /mm	MAX/mm
A	0.70	0.75	0.80
A1	0	0.02	0.05
A3	0.203 REF		
D	2.90	3.00	3.10
E	2.90	3.00	3.10
D2	2.05	2.15	2.25
Nd	1.95BSC		
E2	1.10	1.20	1.30
b	0.25	0.30	0.35
e	0.65 TYP		
k	0.50REF		
L	0.35	0.4	0.45
h	0.20	0.25	0.30

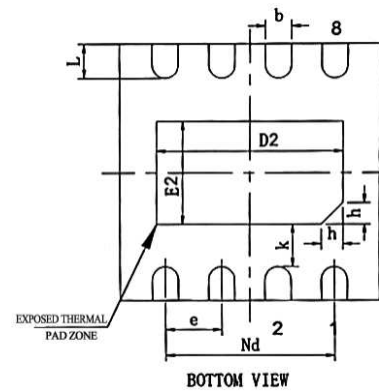
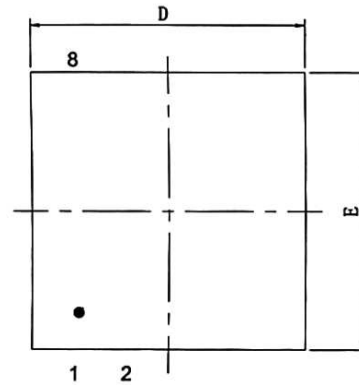
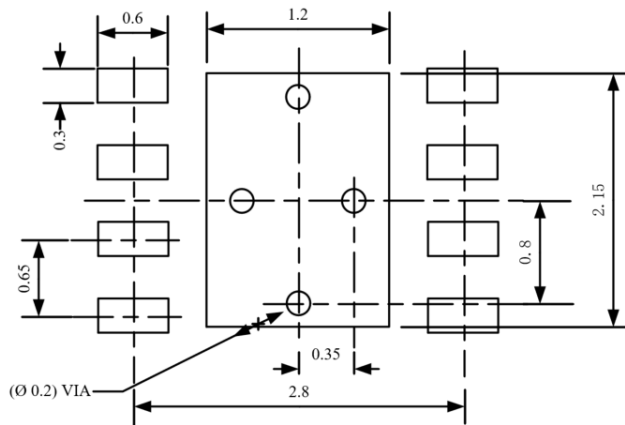
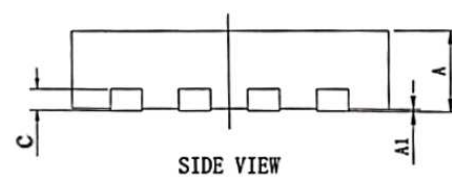
BOTTOM VIEW

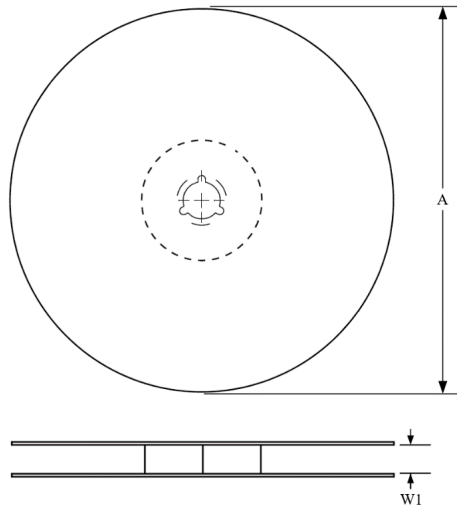
LAND PATTERN EXAMPLE (Unit: mm)

SIDE VIEW

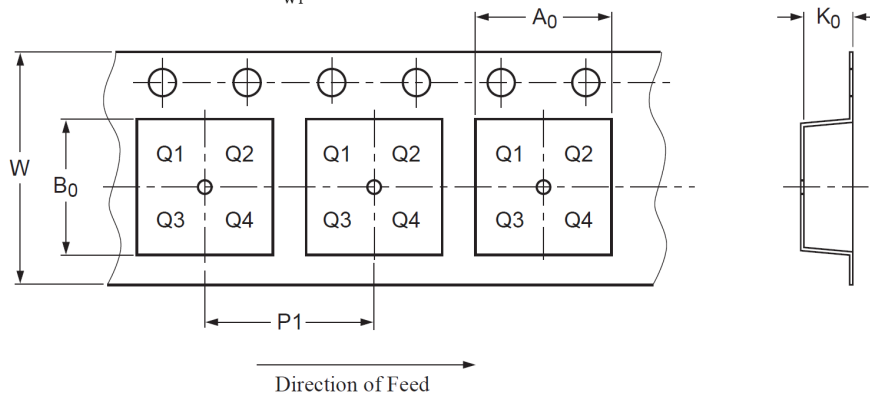
TAPE AND REEL INFORMATION

A0	Dimension designed to accommodate the component width
B0	Dimension designed to accommodate the component length
K0	Dimension designed to accommodate the component thickness
W	Overall width of the carrier tape
P1	Pitch between successive cavity centers



PIN1 is in quadrant 1

Package Type	Reel Diameter A (mm)	Tape Width W1 (mm)	A0 (mm)	B0 (mm)	K0 (mm)	P1 (mm)	W (mm)
SOP8	330±1	12.4	6.60±0.1	5.30±0.10	1.90±0.1	8.00±0.1	12.00±0.1
DFN3*3-8	329±1	12.4	3.30±0.1	3.30±0.1	1.10±0.1	8.00±0.1	12.00±0.3

ORDERING INFORMATION

TYPE NUMBER	PACKAGE	PACKING
SIT1042AT	SOP8	Tape and reel
SIT1042AT/3	SOP8	Tape and reel
SIT1042ATK/3	DFN3*3-8, small shape, no leads, 8 terminals	Tape and reel

SOP8 is packed with 2500 pieces/disc in braided packaging. Leadless DFN3*3-8 is packed with 6000 pieces/disc in braided packaging.

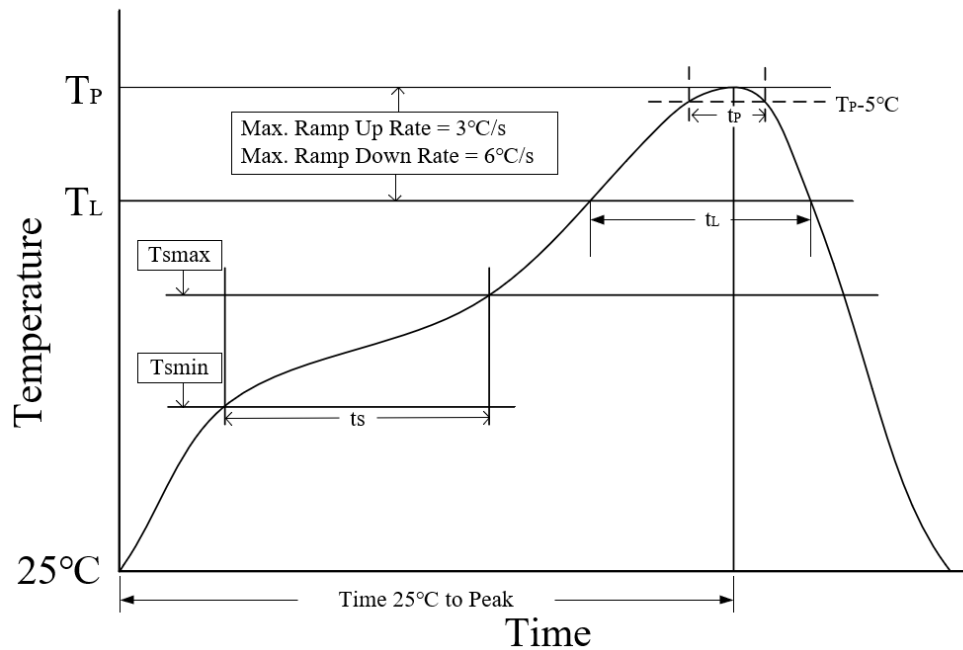
REFLOW SOLDERING

Parameter	Lead-free soldering conditions
Ave ramp up rate (T_L to T_P)	3 °C/second max
Preheat time t_s ($T_{smin}=150\text{ °C}$ to $T_{smax}=200\text{ °C}$)	60-120 seconds
Melting time t_L ($T_L=217\text{ °C}$)	60-150 seconds
Peak temp T_P	260-265 °C
5°C below peak temperature t_p	30 seconds
Ave cooling rate (T_P to T_L)	6 °C/second max
Normal temperature 25°C to peak temperature T_P time	8 minutes max

Important statement

SIT reserves the right to change the above-mentioned information without prior notice.

REVISION HISTORY

Version number	Data sheet status	Revision Date
V1.0	Initial version.	March 2023