



HESTORE.HU

elektronikai alkatrész áruház

EN: This Datasheet is presented by the manufacturer.

Please visit our website for pricing and availability at www.hestore.hu.

QT-Brightek Chip LED Series

0402 SMD Chip LED

Part No.: QBLP595 Series

Table of Contents:

Introduction	3
Electrical / Optical Characteristic (Ta=25 °C)	4
Absolute Maximum Rating	4
Characteristic Curves.....	7
Solder Profile & Footprint.....	9
Packing	10
Labeling	11
Ordering Information	11
Revision History	12
Disclaimer	12

Introduction

Feature:

- Water clear lens
- Package in tape and reel
- Compact 0402 package
- AllnGaP technology for R/Y/AG/O
- InGaN technology for IB/IG
- Viewing Angle: 140° typ.

Description:

These compact 0402 LEDs have a height profile of 0.5mm. Combination of high brightness output and small footprint, these LEDs are ideal for keypad backlighting and status indication.

Application:

- Status indication
- Back lighting application

Certification & Compliance:

- ISO9001
- RoHS Compliant



Dimension:

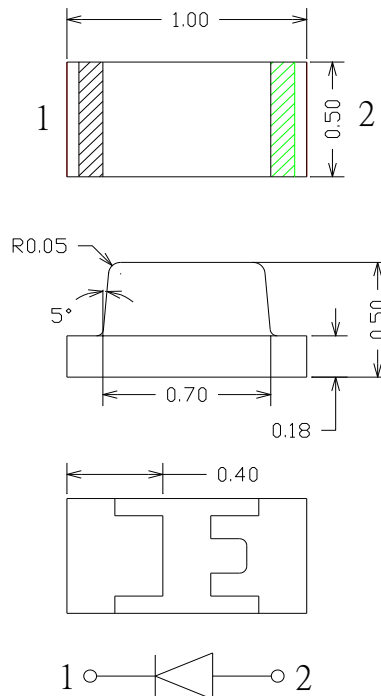

Units: mm / tolerance = +/-0.1mm

Electrical / Optical Characteristic (Ta=25 °C)

Product	Color	I _F (mA)	V _F (V)		λ _D (nm)			I _V (mcd)	
			Typ.	Max.	Min.	Typ.	Max.	Min.	Typ.
QBLP595-R	Red	20	2.0	2.5	615	620	630	63	120
QBLP595-O	Orange	20	2.0	2.5	600	605	610	80	165
QBLP595-Y	Yellow	20	2.0	2.5	585	590	595	50	95
QBLP595-AG	Yellow Green	20	2.0	2.5	565	570	576	16	30
QBLP595-IG	True Green	20	3.1	3.7	515	520	525	320	600
QBLP595-IB	Blue	20	3.1	3.7	460	465	470	50	85

Absolute Maximum Rating

Material	P _d (mW)	I _F (mA)	I _{FP} (mA)*	V _R (V)	T _{OP} (°C)	T _{ST} (°C)	T _{SO L} (°C)**
AllnGaP	75	30	125	5	-40 ~ +80	-40 ~ +85	260
InGaN	111	30	125	5	-40 ~ +80	-40 ~ +85	260

*Duty 1/8 @ 1KHz

**IR Reflow for no more than 10 sec @ 260 °C

Forward Voltage V_F for AllnGaP @ I_F=20mA

Bin	Min.	Max.	Unit
□	1.7	2.5	V

Forward Voltage V_F for InGaN @ I_F=20mA

Bin	Min.	Max.	Unit
f	2.8	3.1	V
g	3.1	3.4	
h	3.4	3.7	

Luminous Intensity I_V @ $I_F=20mA$

Bin	Min.	Max.	Unit
B	16	20	mcd
C	26	25	
D	25	32	
E	32	40	
F	40	50	
G	50	63	
H	63	80	
I	80	100	
J	100	125	
K	125	160	
L	160	200	
M	200	250	
N	250	320	
O	320	400	
P	400	500	
Q	500	630	
R	630	800	
S	800	1000	

Dominant Wavelength λ_D for Red @ $I_F=20mA$

Bin	Min.	Max.	Unit
s	615	620	nm
t	620	625	
u	625	630	

Dominant Wavelength λ_D for Yellow @ $I_F=20mA$

Bin	Min.	Max.	Unit
m	585	590	nm
n	590	595	

Dominant Wavelength λ_D for Orange @ $I_F=20mA$

Bin	Min.	Max.	Unit
p	600	605	nm
q	605	610	

Dominant Wavelength λ_D for Yellow Green @ $I_F=20mA$

Bin	Min.	Max.	Unit
h	565	568	nm
i	568	572	
j	572	576	

Dominant Wavelength λ_D for Blue @ $I_F=20mA$

Bin	Min.	Max.	Unit
E	460	462.5	nm
F	462.5	465	
G	465	467.5	
H	467.5	470	

Dominant Wavelength λ_D for True Green @ $I_F=20mA$

Bin	Min.	Max.	Unit
S	515	517.5	nm
T	517.5	520	
U	520	522.5	
V	522.5	525	

Note:

Tolerance of measurement of forward voltage: $\pm 0.1V$ Tolerance of measurement of luminous intensity: $\pm 15\%$ Tolerance of measurement of dominant wavelength: $\pm 2nm$

Characteristic Curves

AllnGaP Technology (R/Y/O/AG)

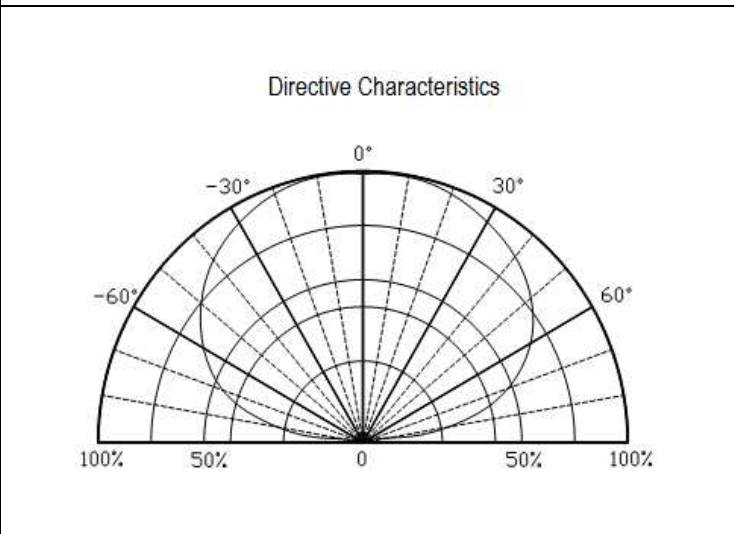
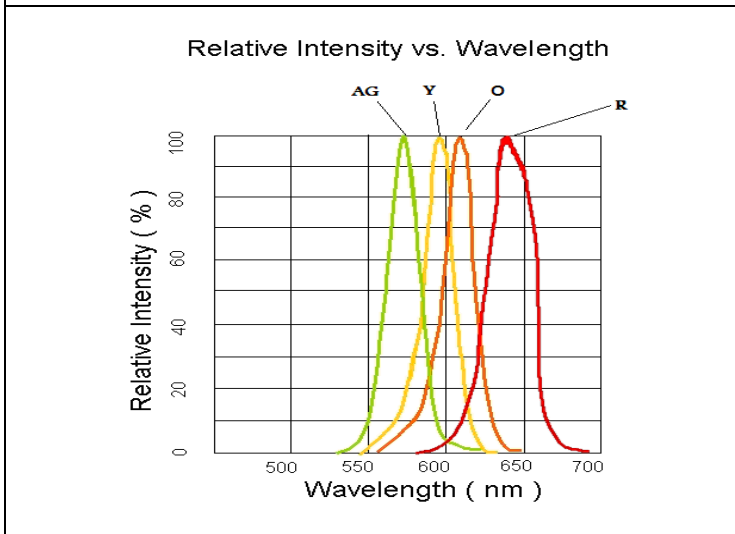
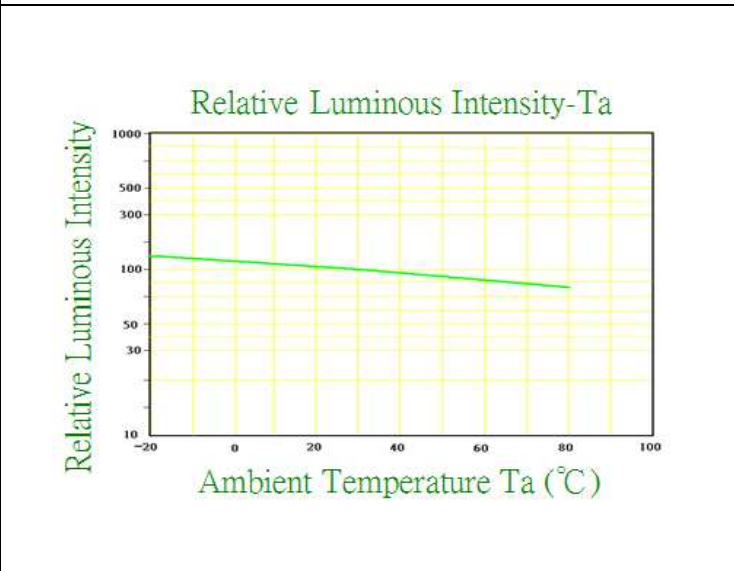
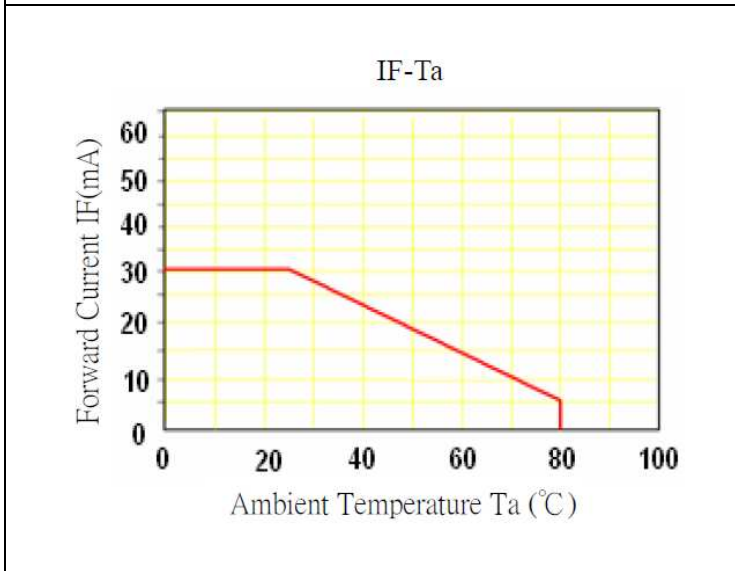
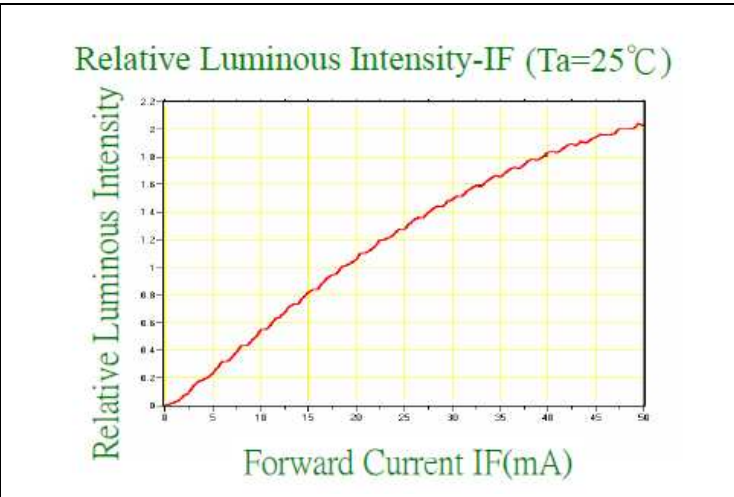
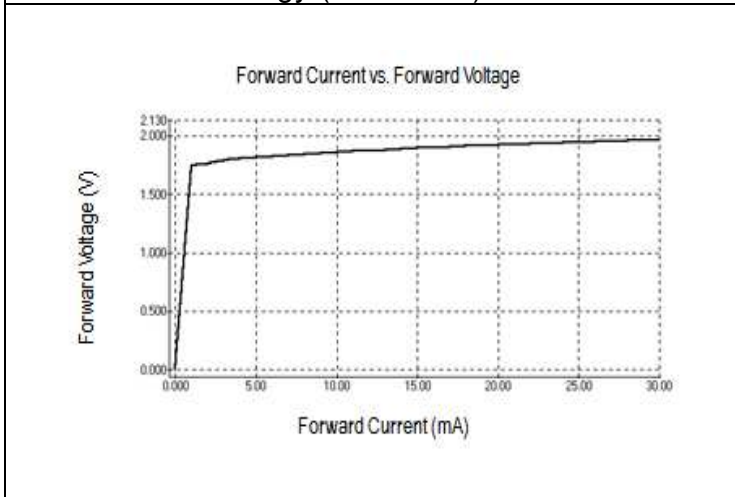

InGaN Technology (IG/IB)

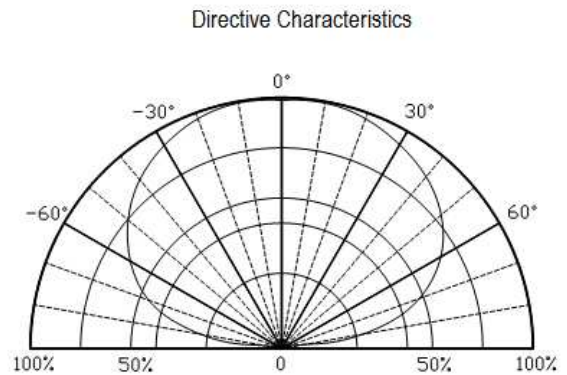
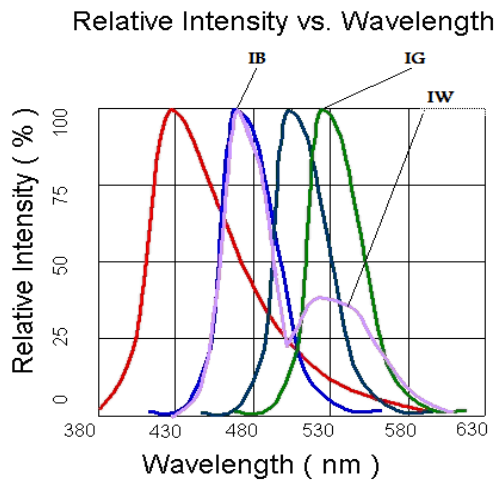
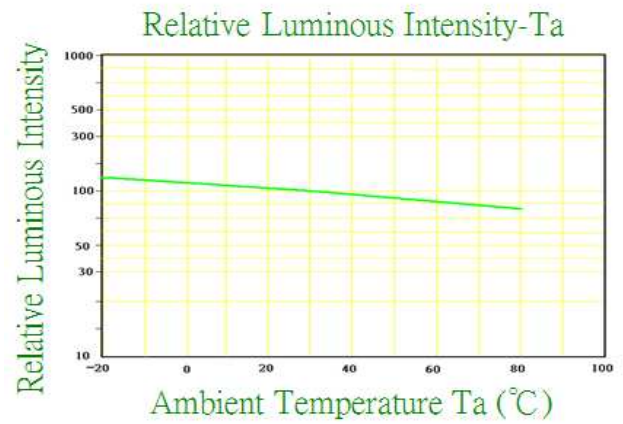
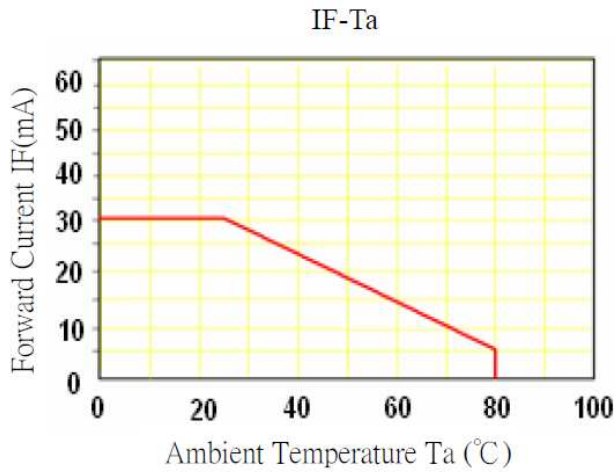
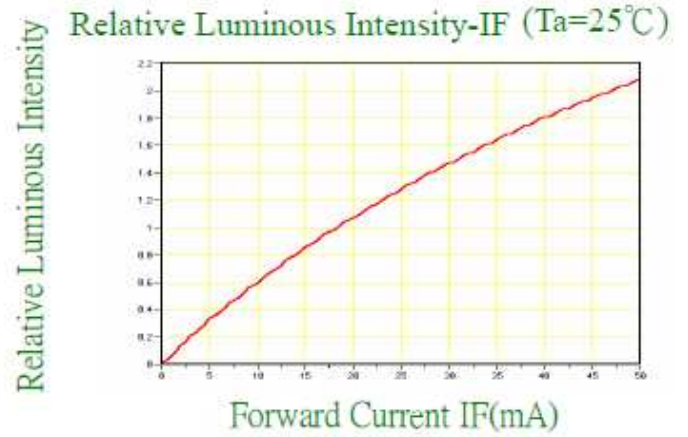
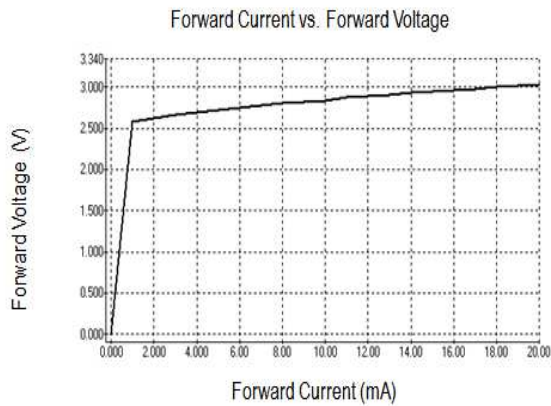

Solder Profile & Footprint

-The recommended reflow soldering profile is as follows (temperatures indicated are as measured on the surface of the LED resin):

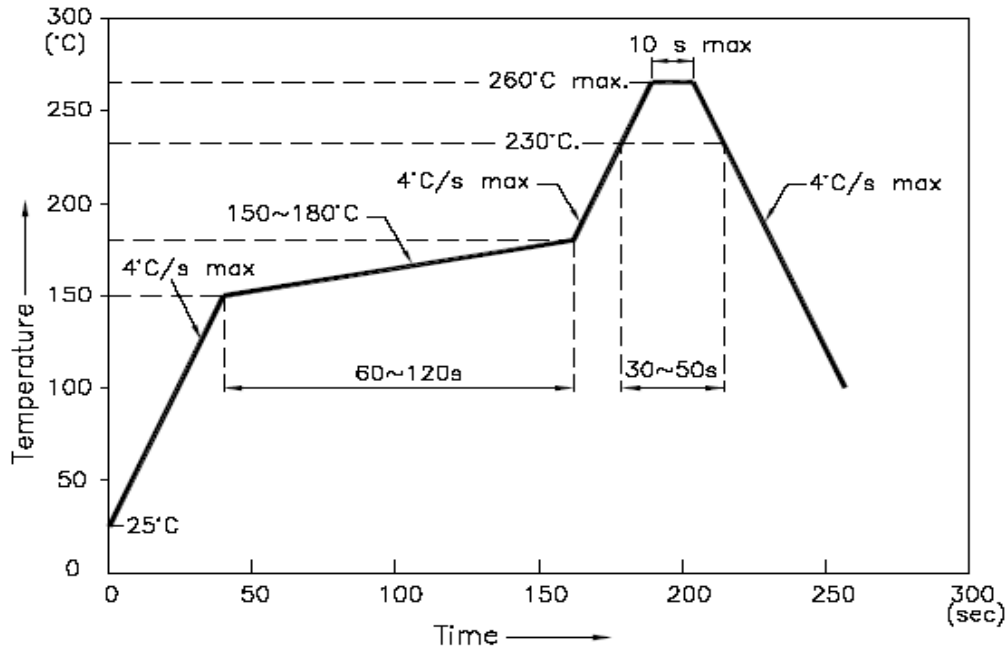

Recommended Pad Layout

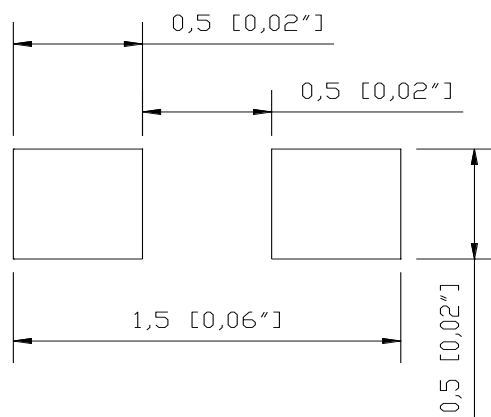

Units: mm

Tolerance: $\pm 0.1\text{mm}$

Product: QBLP595 Series	Date: September 15, 2016	Page 9 of 12
	Version# 1.3	

Packing

Reel Dimension:

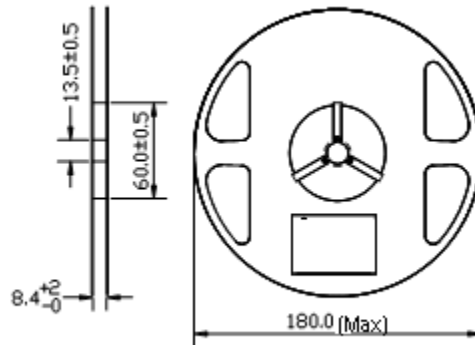

(Unit: mm)

Tape Dimension:

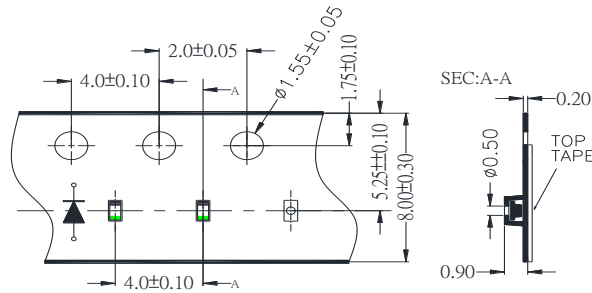

(Unit: mm)

Arrangement of Tape:

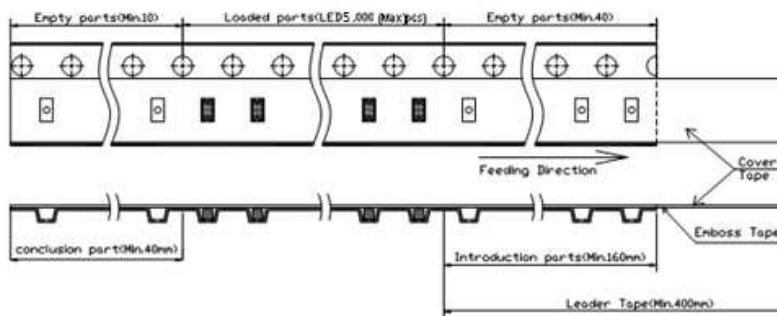

Packaging Specifications:

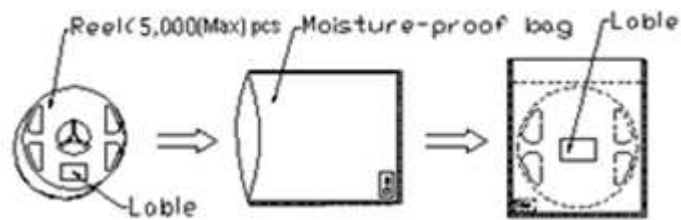

Labeling

Part No: _____
 Customer P/N: _____
 Item: _____
 Q'ty: _____
 Vf: _____
 Iv: _____
 WI: _____
 Date: _____

Made in China**Ordering Information**

Part #	Orderable Part #	Spec Range	Quantity per reel
QBLP595-R	QBLP595-R	Iv=120mcd typ. λ_D =615nm to 630nm	5,000 units
QBLP595-O	QBLP595-O	Iv=165mcd typ. λ_D =600nm to 610nm	5,000 units
QBLP595-Y	QBLP595-Y	Iv=95mcd typ. λ_D =585nm to 595nm	5,000 units
QBLP595-AG	QBLP595-AG	Iv=30mcd typ. λ_D =565nm to 576nm	5,000 units
QBLP595-IG	QBLP595-IG	Iv=600mcd typ. λ_D =515nm to 525nm	5,000 units
QBLP595-IB	QBLP595-IB	Iv=85mcd typ. λ_D =460nm to 470nm	5,000 units

Revision History

Description:	Revision #	Revision Date
New Release of QBLP595 Series	V1.0	06/03/2016
Update the brightness for IG	V1.1	06/10/2016
Add the color Orange/ amend the brightness on Yellow and Yellow-green	V1.2	09/08/2016
Update the wavelength bin for IG / Fix the Recommended Pad Layout error	V1.3	09/15/2016

Disclaimer

QT-BRIGHTTEK reserves the right to make changes without further notice to any products herein to improve reliability, function or design. QT-BRIGHTTEK does not assume any liability arising out of the application or use of any product or circuit described herein; neither does it convey any license under its patent rights, nor the rights of others.

Life Support Policy

QT-BRIGHTTEK's products are not authorized for use as critical components in life support devices or systems without the express written approval of QT-BRIGHTTEK. As used herein:

1. Life support devices or systems are devices or systems which, (a) are intended for surgical implant into the body, or (b) support or sustain life, and (c) whose failure to perform when properly used in accordance with instructions for use provided in the labeling, can be reasonably expected to result in a significant injury of the user.
2. A critical component in any component of a life support device or system whose failure to perform can be reasonably expected to cause the failure of the life support device or system, or to affect its safety or effectiveness.