



HESTORE.HU

elektronikai alkatrész áruház

EN: This Datasheet is presented by the manufacturer.

Please visit our website for pricing and availability at www.hestore.hu.

MOSFET Driver Selector Guide



A Leading Provider of Smart, Connected and Secure Embedded Control Solutions

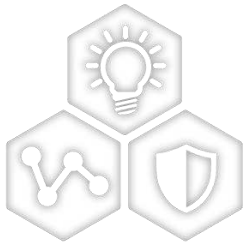

SMART | CONNECTED | SECURE

MOSFET Driver Selector Guide

Rev A2 07/15/2020

What kind of Application are you using this driver for?

Automotive

Commercial

Motor Drive

Automotive Drivers

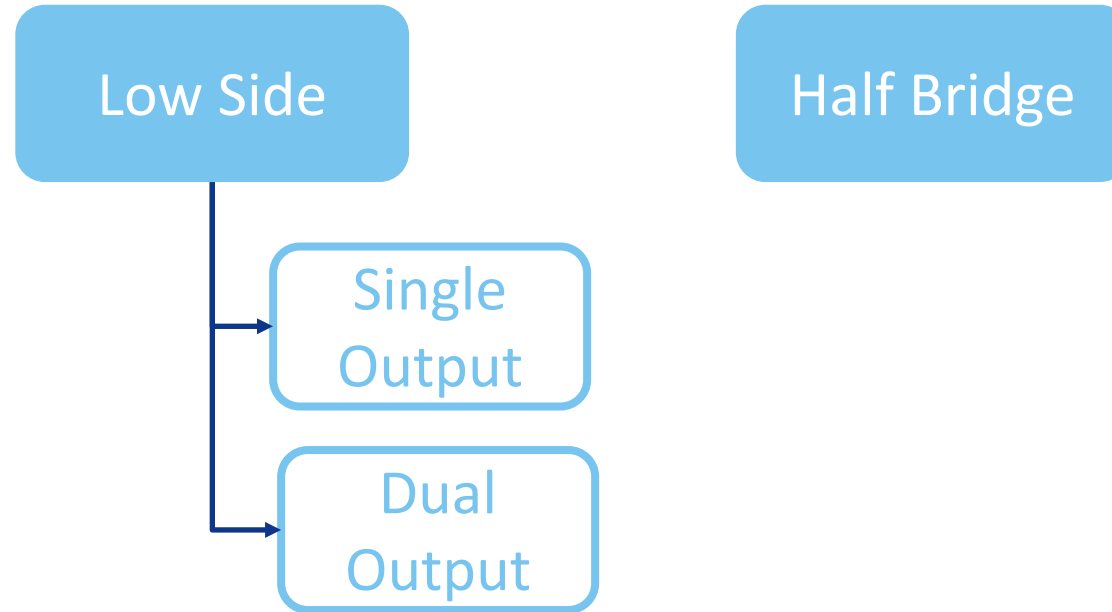

Automotive Single Output

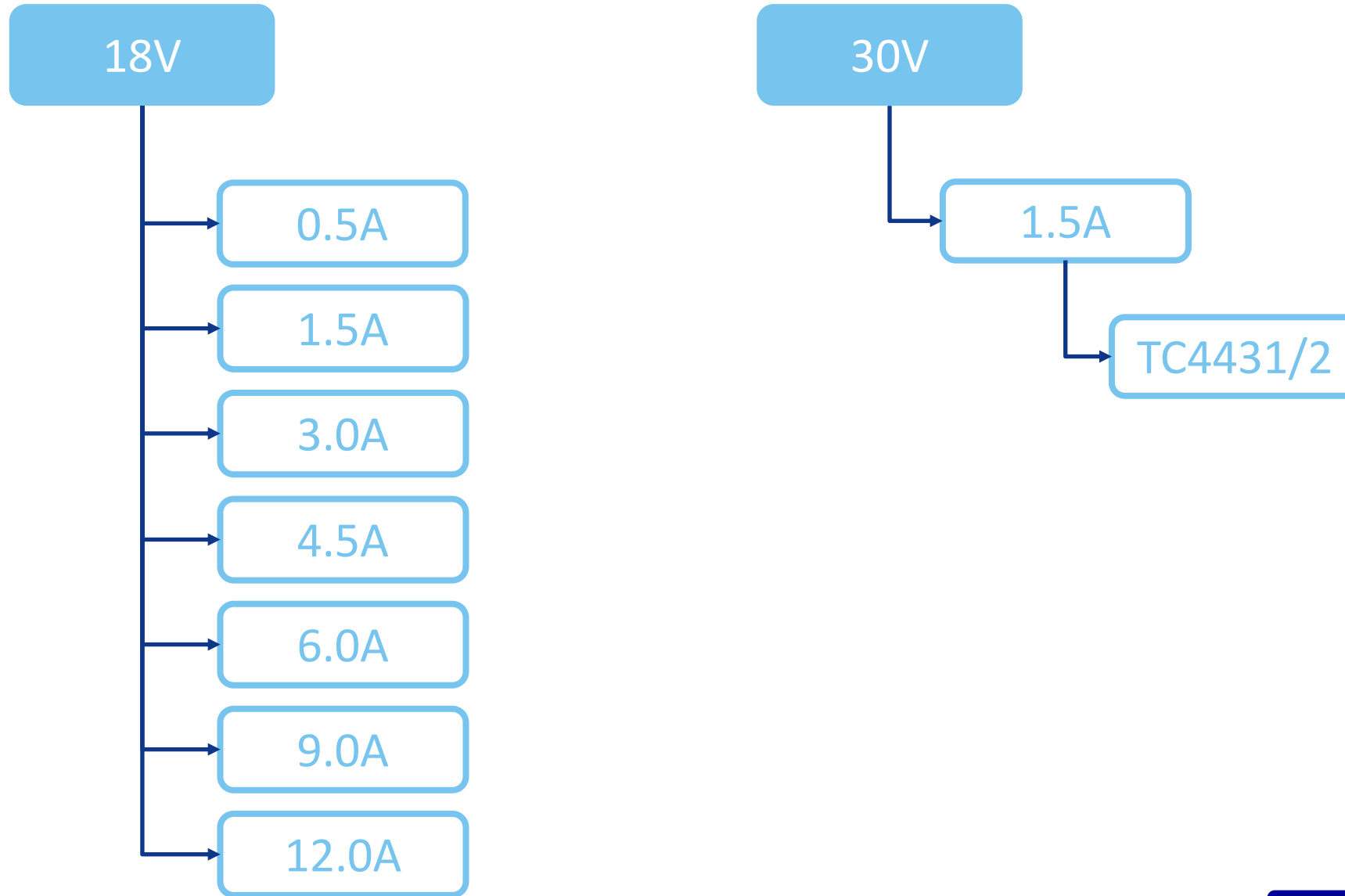

<< BACK

Automotive Single 0.5A Output

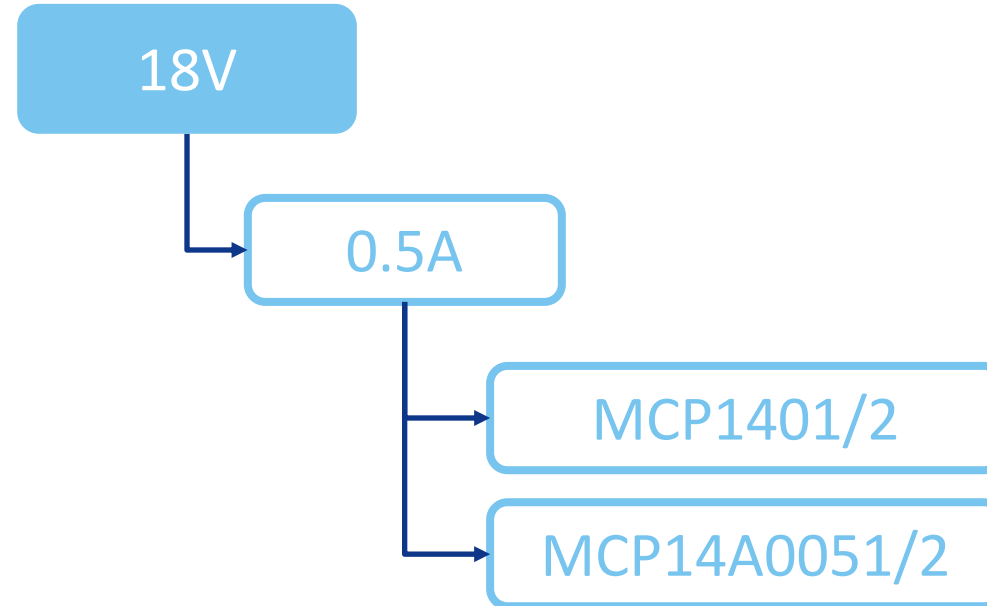

Automotive Single 1.5A Output

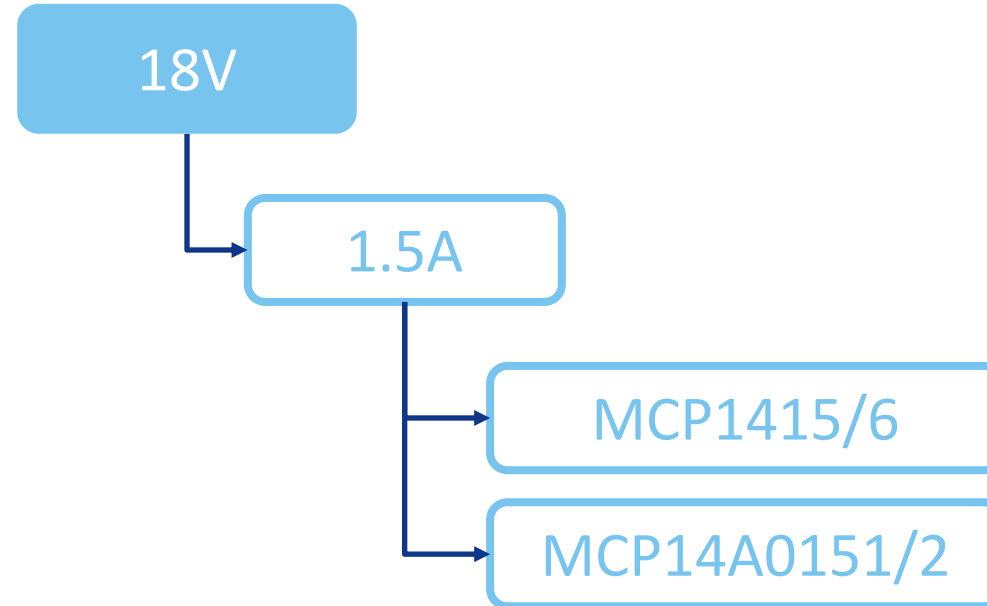

Automotive Single 3.0A Output

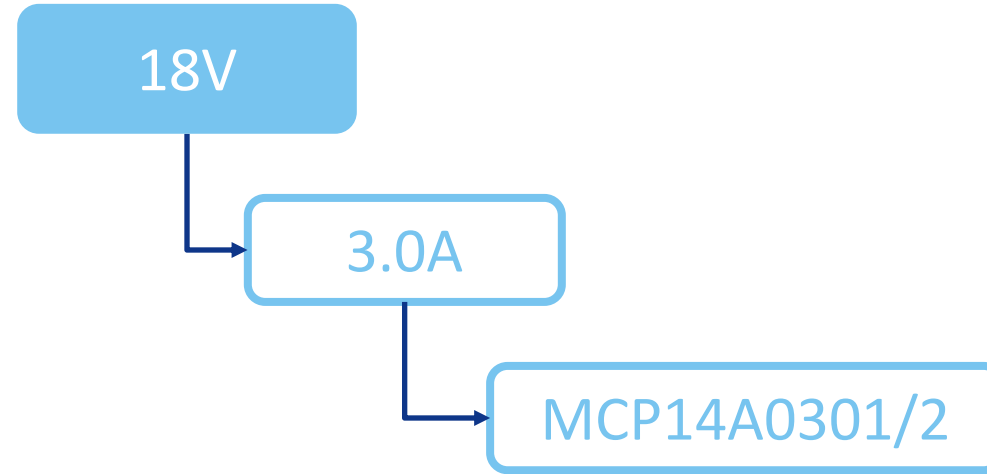

Automotive Single 4.5A Output

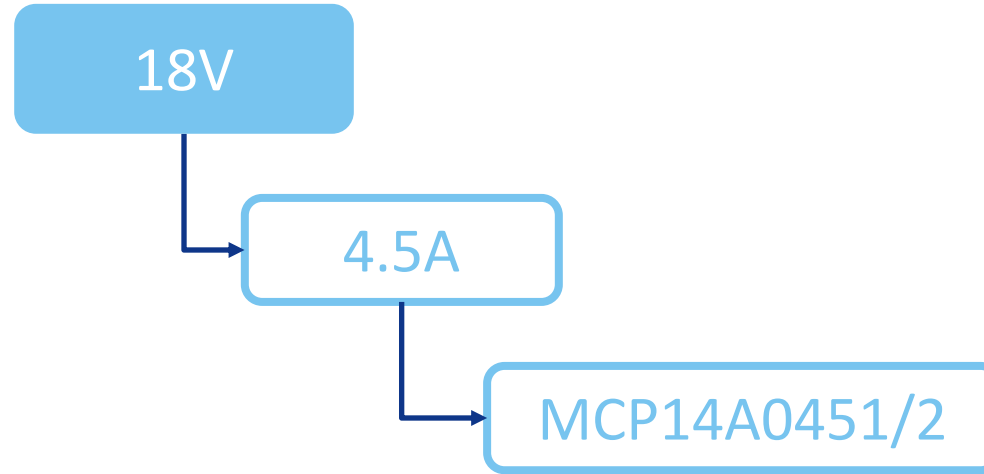

Automotive Single 6.0A Output

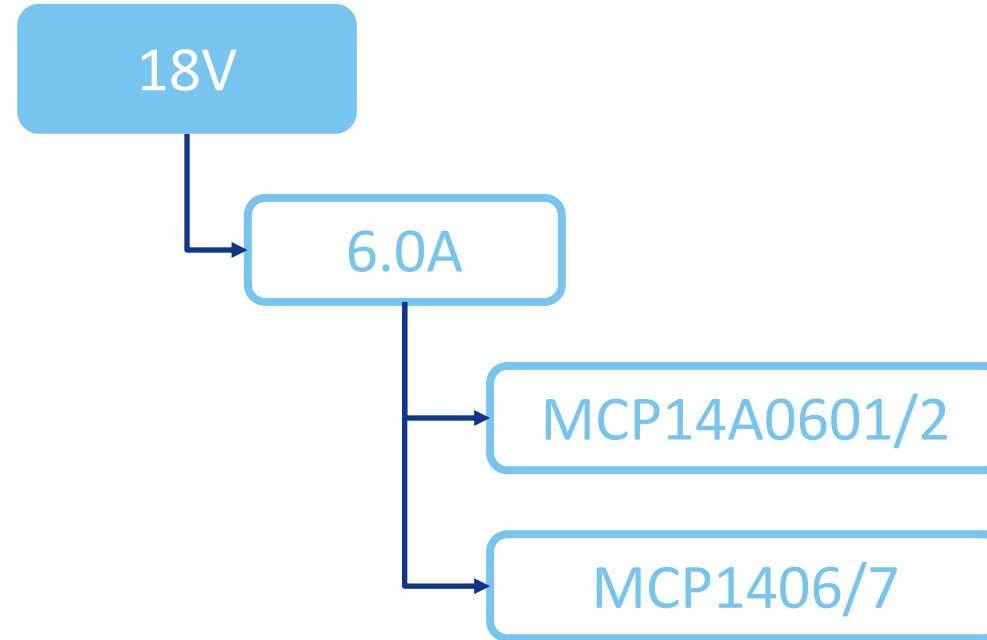

Automotive Single 9.0A Output

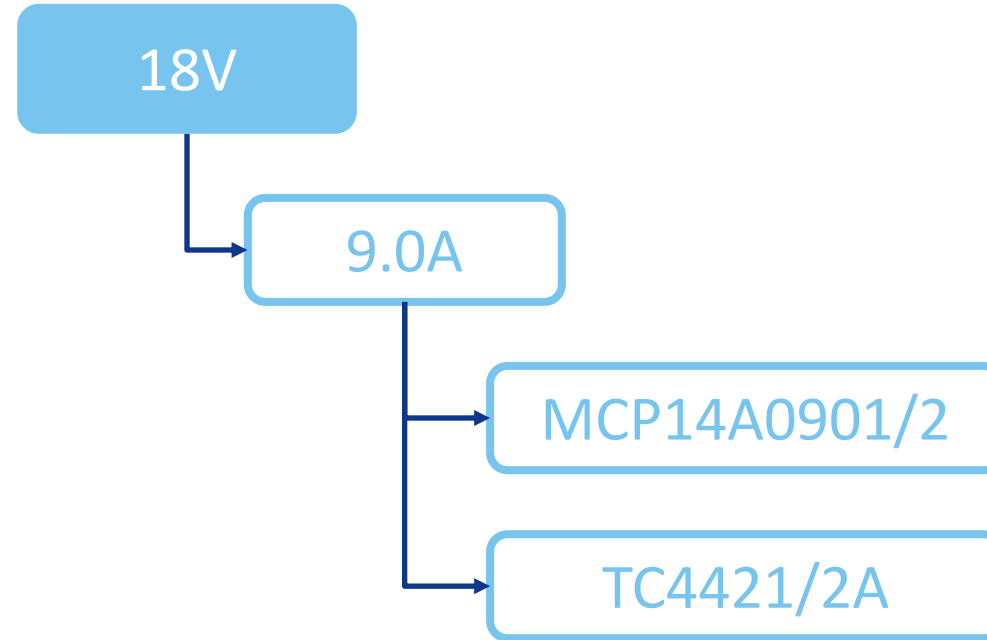

Automotive Single 12.0A Output

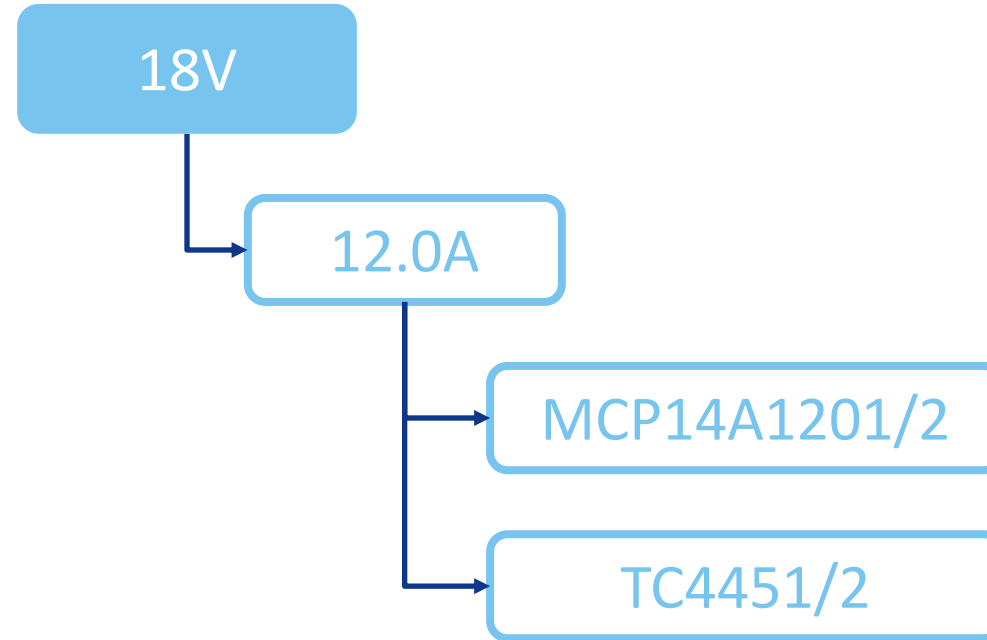

Automotive Half Bridge Driver

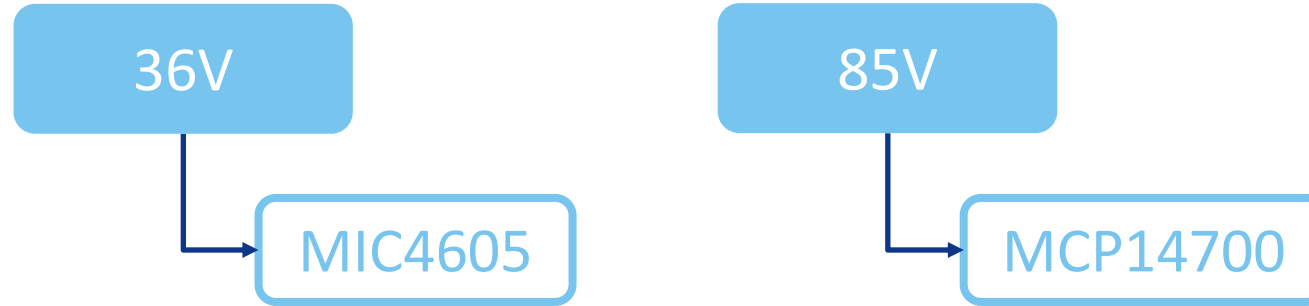

Automotive Dual Output

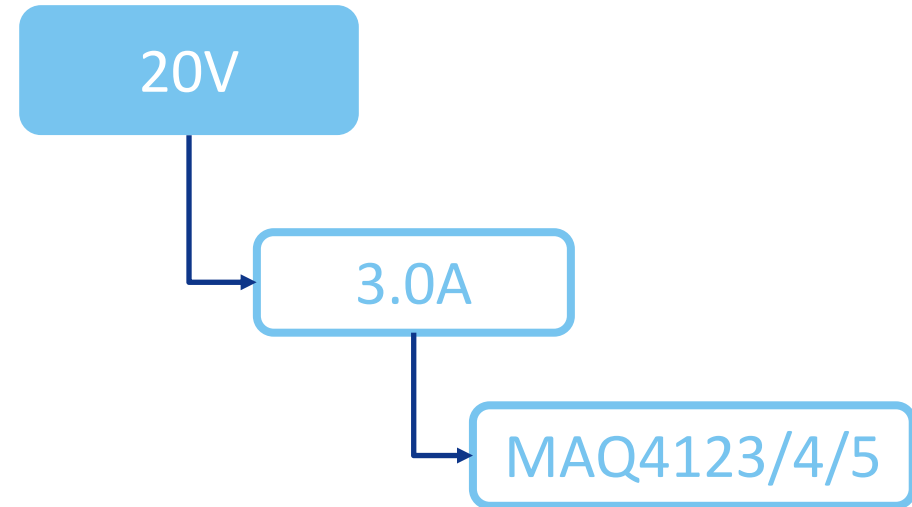
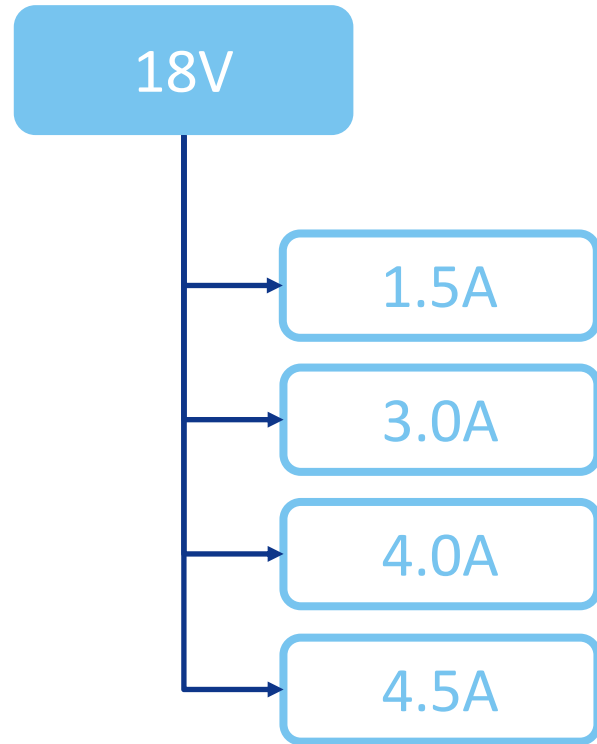

Automotive Dual 1.5A Output

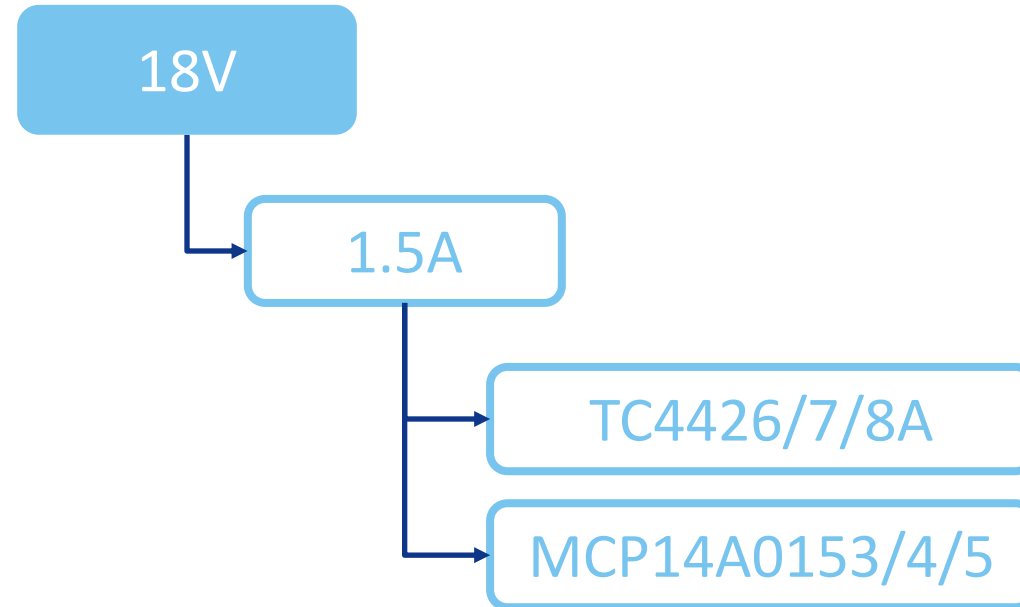

Automotive Dual 3.0A Output

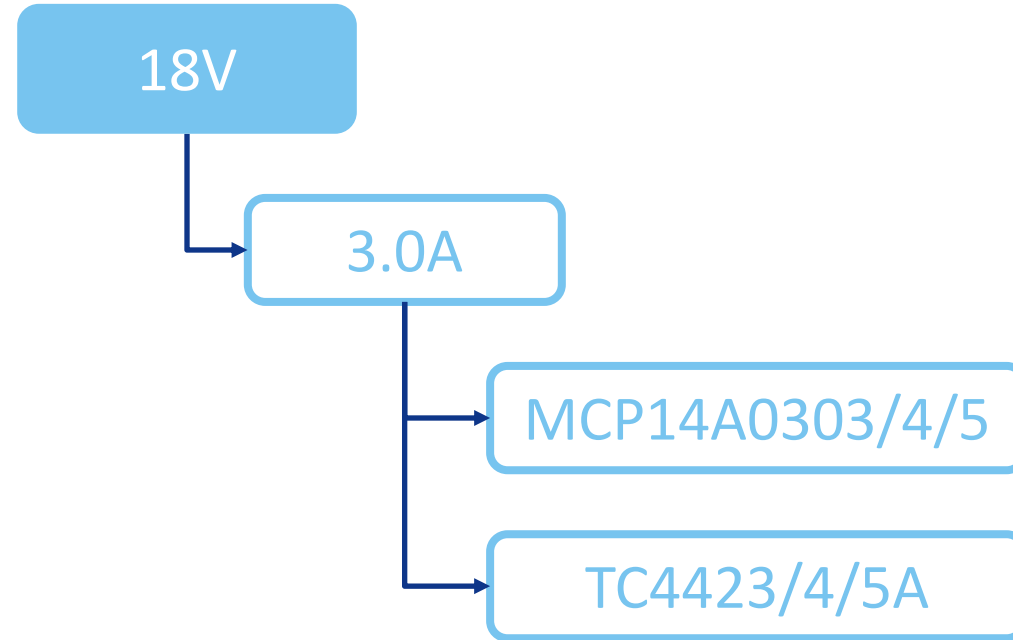

Automotive Dual 4.0A Output

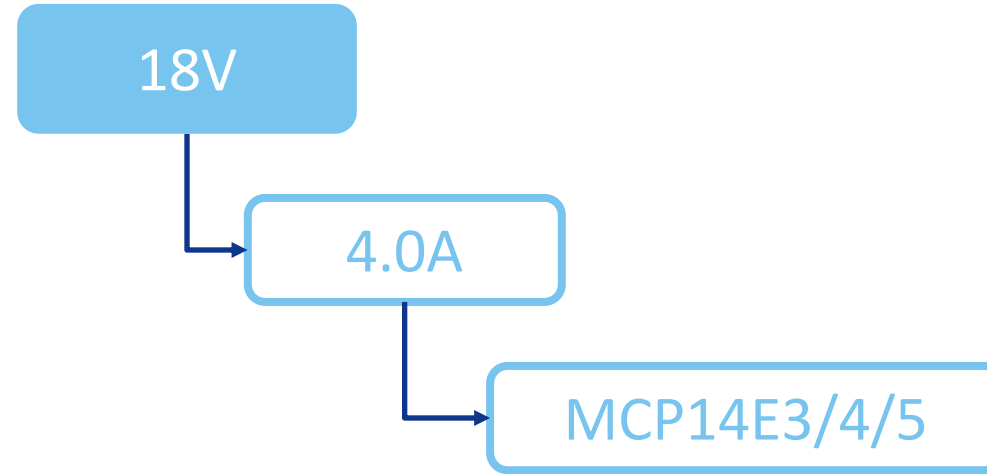

Automotive Dual 4.5A Output

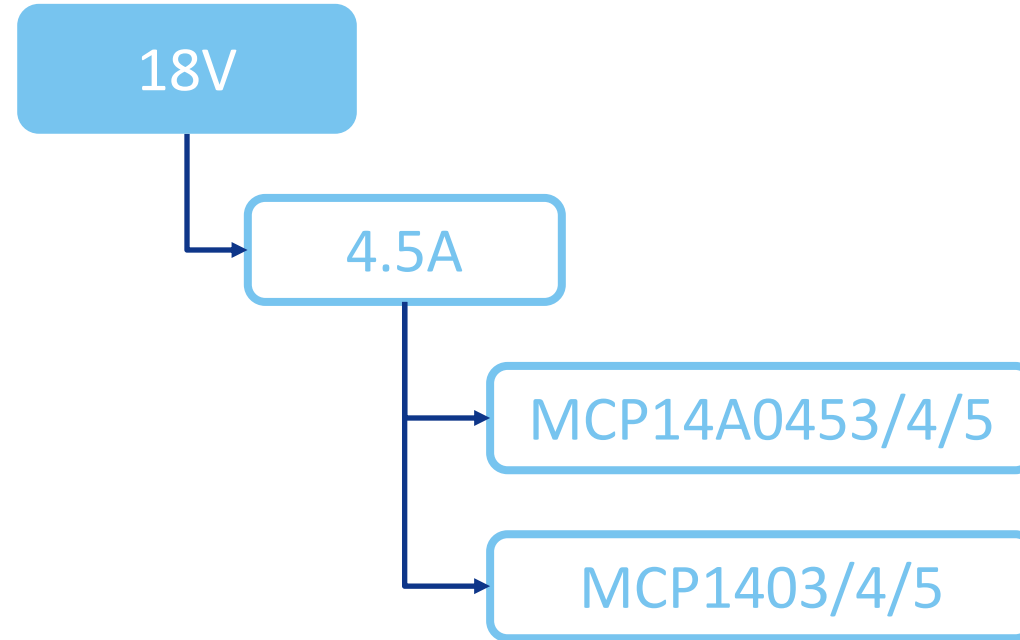

Commercial Drivers

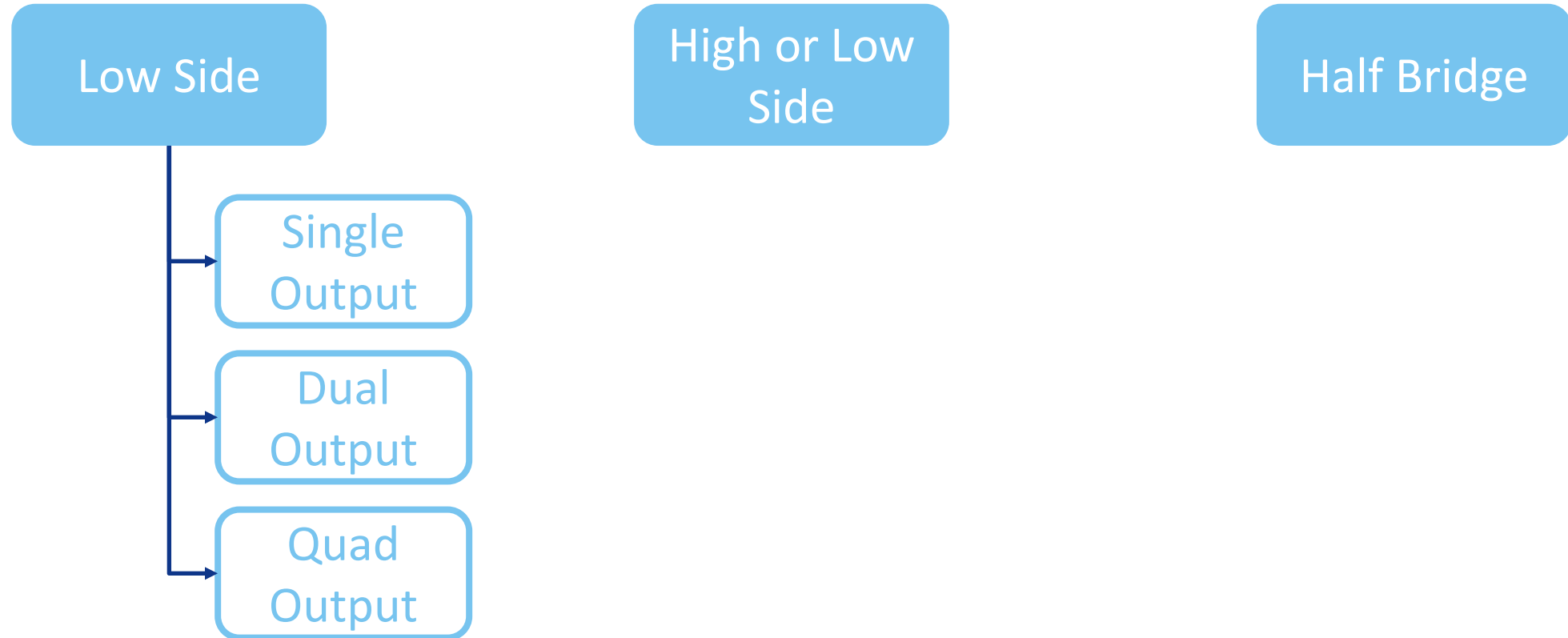

Commercial Low Side Single Output

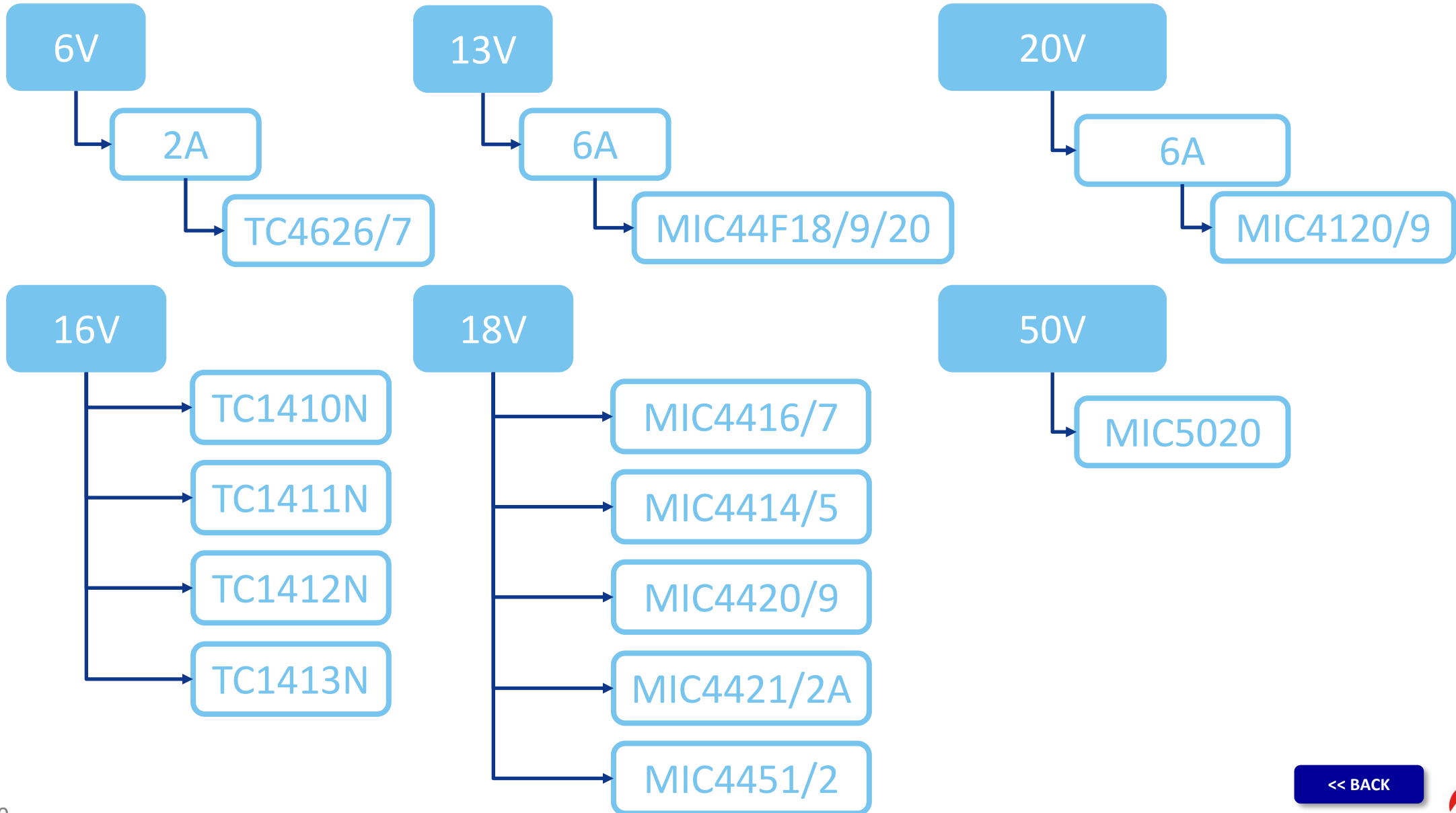

Commercial Low Side Dual Output

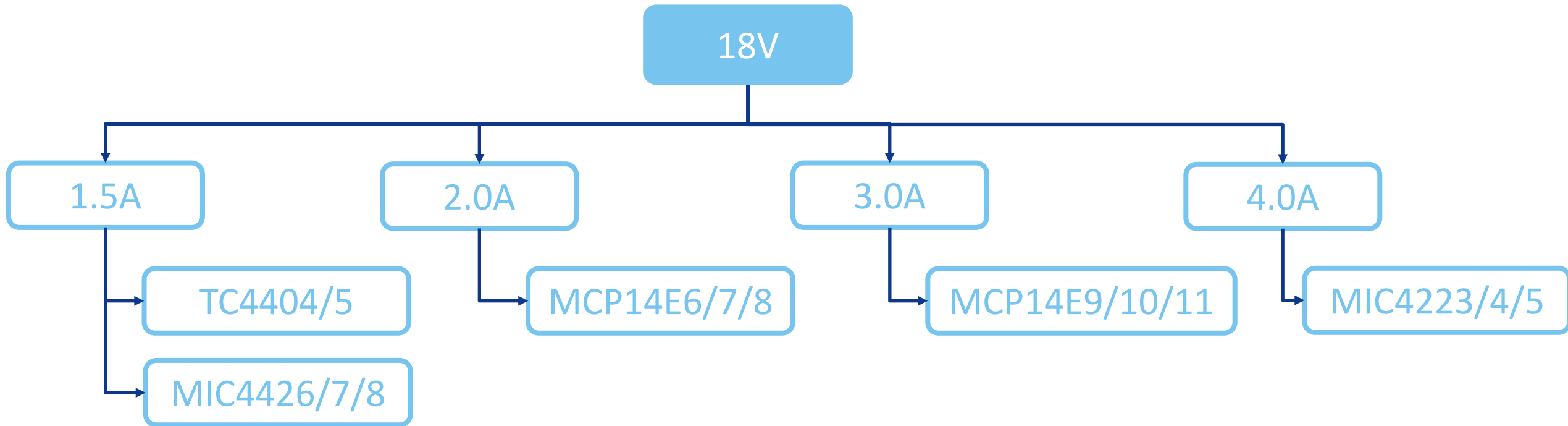

Commercial Low Side Quad Output

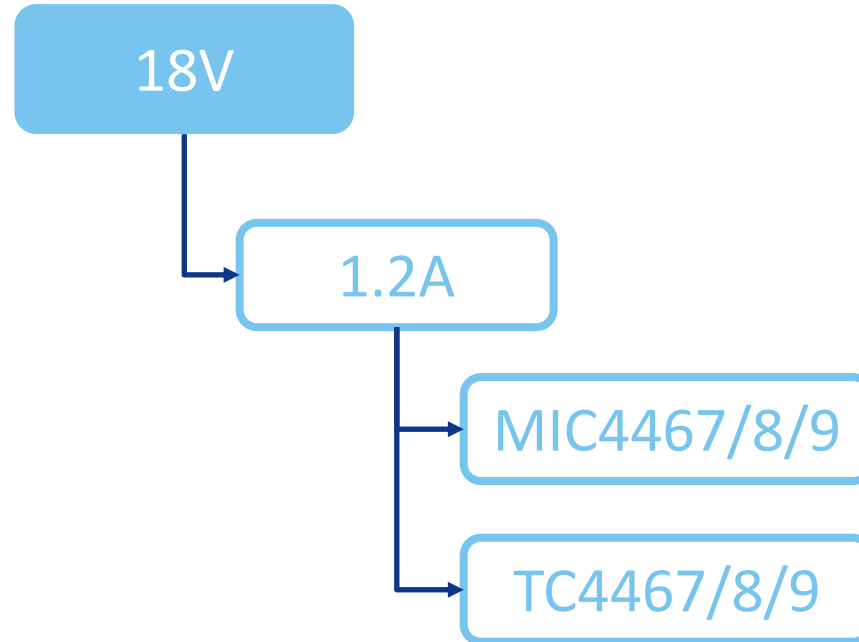

Commercial High/Low Side Drivers

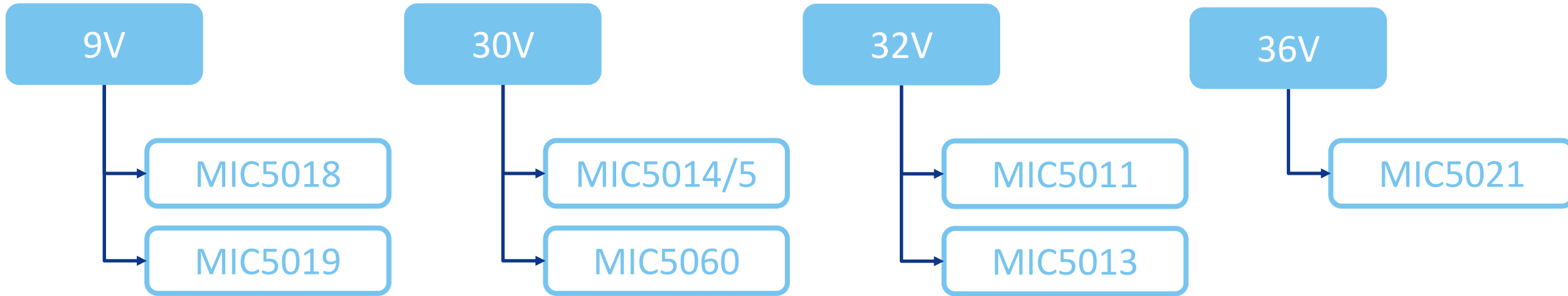

Commercial Half Bridge Drivers

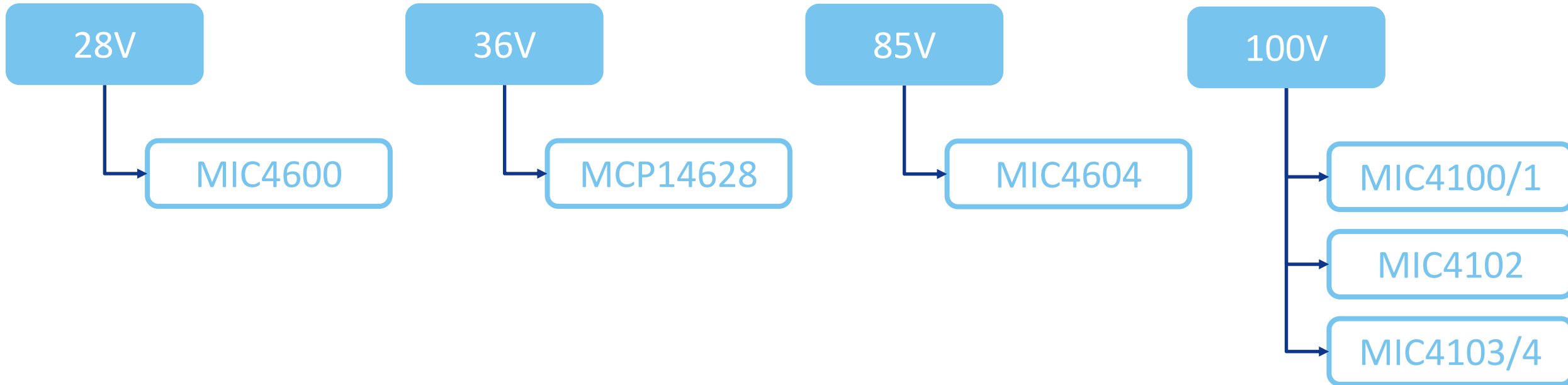

Motor Drivers

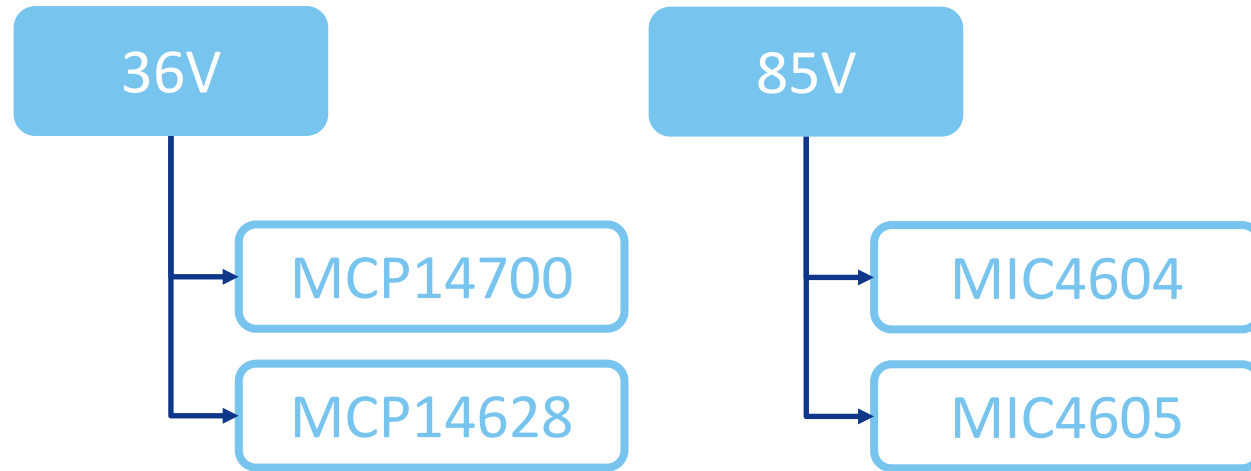

MIC5020

Current-Sensing Low-Side MOSFET Driver

[Online Datasheet](#)

Features:

- 11V to 50V operation
- 175ns rise/fall time driving 2000pF
- TTL compatible input with internal pull –
- down resistor
- Overcurrent limit
- Fault output indication
- Gate to source protection
- Compatible with current sensing –
- MOSFETs

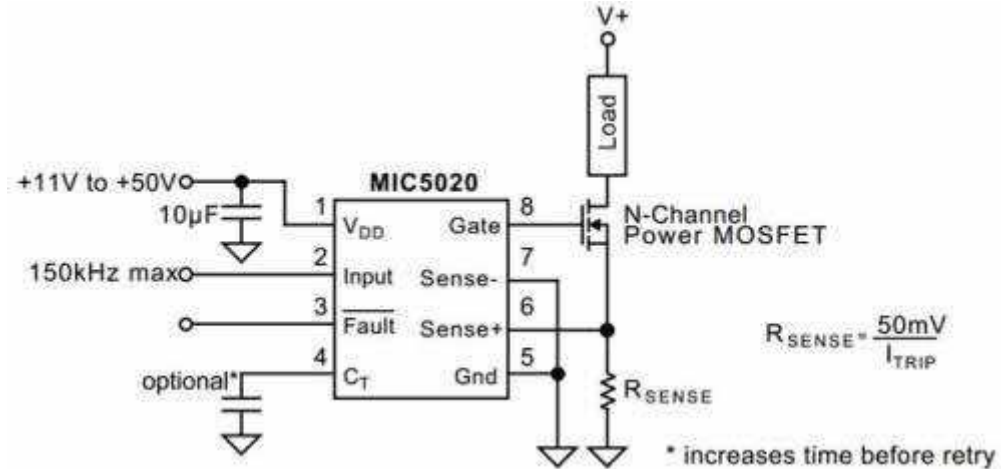

TC4431/2

1.5A High-Speed 30V MOSFET Drivers



Online
Datasheet

Features:

- High Peak Output Current: 1.5A
- Wide Operating Range: 4.5V to 30V
- High Capacitive Load Drive –
 - Capability: 1000pF in 25ns
- Short Delay Times: < 78ns (typ.)
- Low Supply Current:
 - With Logic '1' Input: 2.5mA
 - With Logic '0' Input: 300µA
- Low Output Impedance: 7Ω (typ.)
- Latch-Up Protected: Will Withstand -
 - > 300mA Reverse Current
- ESD Protected: 4kV
- Recommended for Automotive Design (TC4431)

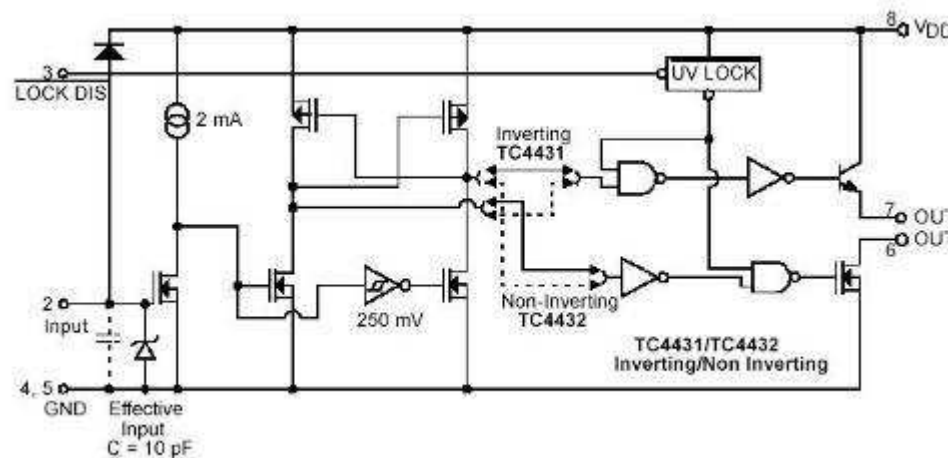

<< BACK

MIC4120/9

6A-Peak Low-Side MOSFET Driver Bipolar/CMOS/DMOS Process

Online
Datasheet

Features:

- Latch-up protected: will withstand $>200\text{mA}$ –
– reverse output current
- Logic input withstands negative swing of up to 5V
- Matched rise and fall times of 25ns
- High peak output current at 6A
- Wide operating range from 4.5V to 20V
- High capacitive load drive of 10,000pF
- Logic high input for any voltage from 2.4V to V_S
- Low equivalent input capacitance (typ) at 6pF
- Low supply current is $450\mu\text{A}$ with logic 1 input
- Low output impedance is 2.5Ω
- Output voltage swing within 25mV of ground or V_S
- Exposed backside pad packaging reduces heat
 - ePad SOIC-8L ($\theta_{JA} = 58^\circ\text{C/W}$)
 - 3mm x 3mm MLF[®]-8L ($\theta_{JA} = 60^\circ\text{C/W}$)

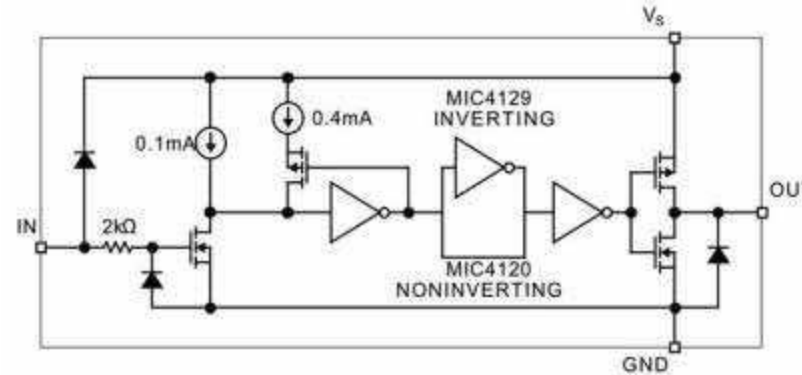

<< BACK

MCP14A1201/2

Description Sub-Title of the Device

Online
Datasheet

Features List:

- High Peak Output Current: 12.0A (typical)
- Wide Input Supply Voltage Operating Range:
 - 4.5V to 18V
- Low Shoot-Through/Cross-Conduction Current in Output Stage
- High Capacitive Load Drive Capability:
 - 15,000 pF in 25 ns (typical)
- Short Delay Times: 28 ns (tD1), 28 ns (tD2) (typical)
- Low Supply Current: 360 μ A (typical)
- Low-Voltage Threshold Input and Enable with Hysteresis
- Latch-Up Protected: Withstands 500 mA Reverse Current
- Space-Saving Packages:
 - 8-Lead MSOP
 - 8-Lead SOIC
 - 8-Lead 2 x 3 TDFN

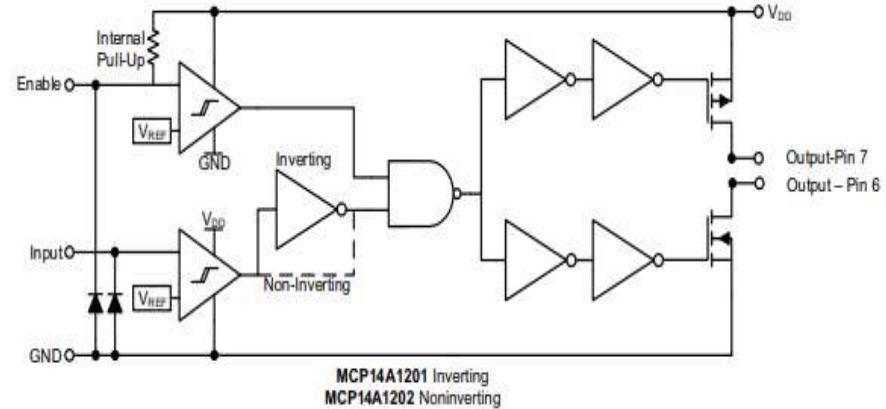

<< BACK

MIC4451/2

12A Peak Low-Side MOSFET Driver Bipolar/CMOS/DMOS Process

Online
Datasheet

Features:

- BiCMOS/DMOS construction
- Latch-up proof: fully isolated process is –
- inherently immune to any latch-up.
- Input will withstand negative swing of –
- up to 5V
- Matched rise and fall times 25ns
- High peak output current 12A peak
- Wide operating range 4.5V to 18V
- High capacitive load drive 62,000pF
- Low delay time 30ns typ.
- Logic high input for any voltage from 2.4V to VS
- Low equivalent input capacitance (typ.) 7pF
- Low supply current 450μA with logic 1 input
- Low output impedance 1.0Ω
- Output voltage swing to within 25mV of ground or VS

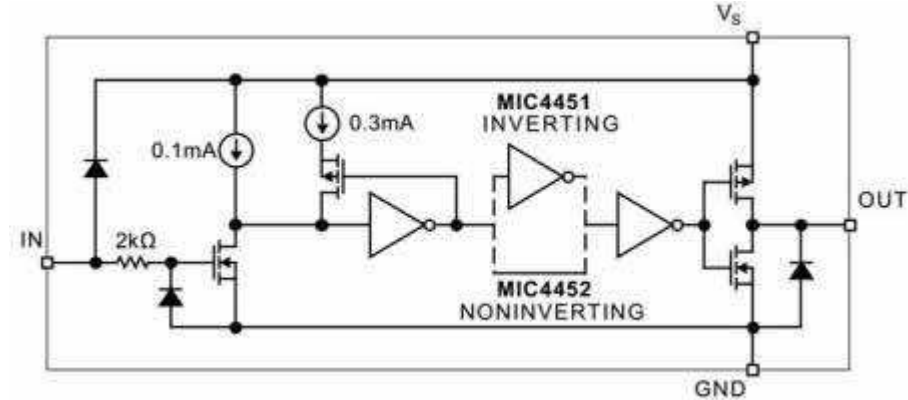

<< BACK

TC4451/4452

12A High-Speed MOSFET Drivers



Online
Datasheet

Features:

- High Peak Output Current: 13A (typ.)
- Wide Input Supply Voltage Operating Range:
 - 4.5V to 18V
- High Continuous Output Current:
 - 2.6A (max.)
- Matched Fast Rise and Fall Times:
 - 21ns with 10,000 pF Load
 - 42ns with 22,000 pF Load
- Matched Propagation Delays: 44ns (typ.)
- Low Supply Current:
 - With Logic '1' Input: 140 μ A (typ.)
 - With Logic '0' Input: 40 μ A (typ.)
- Low Output Impedance: 0.9 Ω (typ.)
- Latch-Up Protected: Will Withstand 1.5A –
- Output Reverse Current
- Input Will Withstand Negative Inputs up to 5V
- Pin-Compatible with the TC4420/TC4429, -
- TC4421/TC4422 and TC4421A/TC4422A
- Space-Saving, Thermally-Enhanced, - 8-Pin DFN Package
- Recommended for Automotive Design (TC4451)

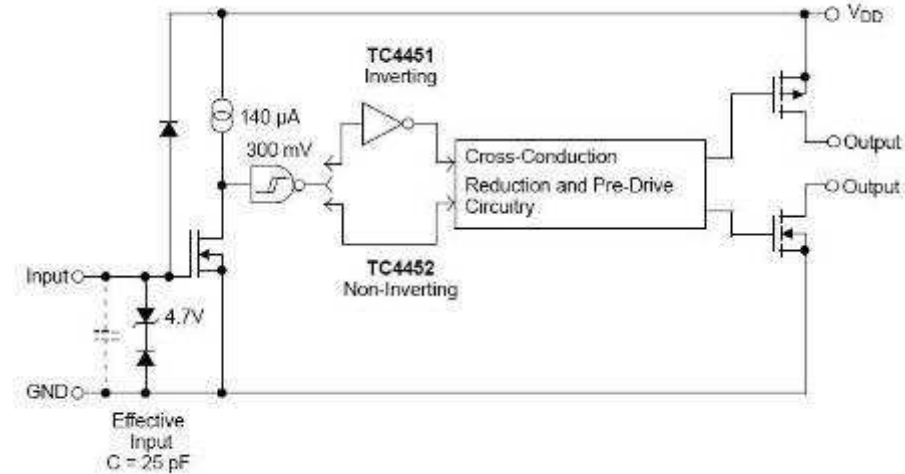

<< BACK

MIC4421A/2A

12A Peak Low-Side MOSFET Driver Bipolar/CMOS/DMOS Process

Online
Datasheet

Features:

- High peak-output current: 9A peak (typ.)
- Wide operating range: 4.5V to 18V (typ.)
- Minimum pulse width: 50ns
- Input will withstand negative swing of up to 5V
- High capacitive load drive: 47,000pF
- Low delay time: 15ns (typ.)
- Logic high input for any voltage from 2.4V to VS
- Low equivalent input capacitance (typ.): 7pF
- Low supply current: 500 μ A (typ.)
- Latch-up proof: fully isolated process is inherently –
– immune to any latch-up.
- Output voltage swing to within 25mV of ground or VS

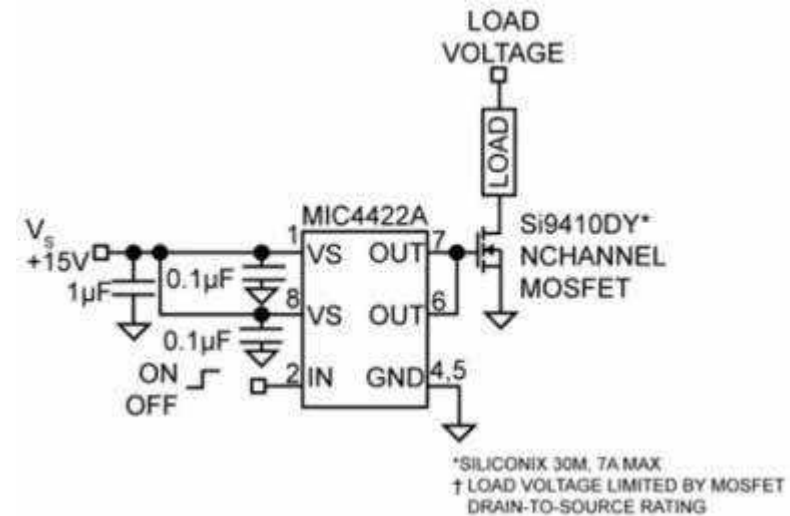

TC4421A/4422A

9A High-Speed MOSFET Drivers



Online
Datasheet

Features:

- High Peak Output Current: 9A
- Wide Input Supply Voltage Operating Range:
 - 4.5V to 18V
- High Continuous Output Current: 2A (max.)
- Fast Rise and Fall Times:
 - 30ns with 4,700pF Load
 - 180ns with 47,000pF Load
- Short Propagation Delays: 30ns (typ.)
- Low Supply Current:
 - With Logic '1' Input: 200 μ A (typ.)
 - With Logic '0' Input: 55 μ A (typ.)
- Low Output Impedance: 1.4 Ω (typ.)
- Latch-Up Protected: Will Withstand 1.5A
 - Output Reverse Current
- Input Will Withstand Negative Inputs up to 5V
- Pin-Compatible with the TC4420/TC4429
- Space-saving 8-Pin 6x5 DFN Package
- Recommended for Automotive Design

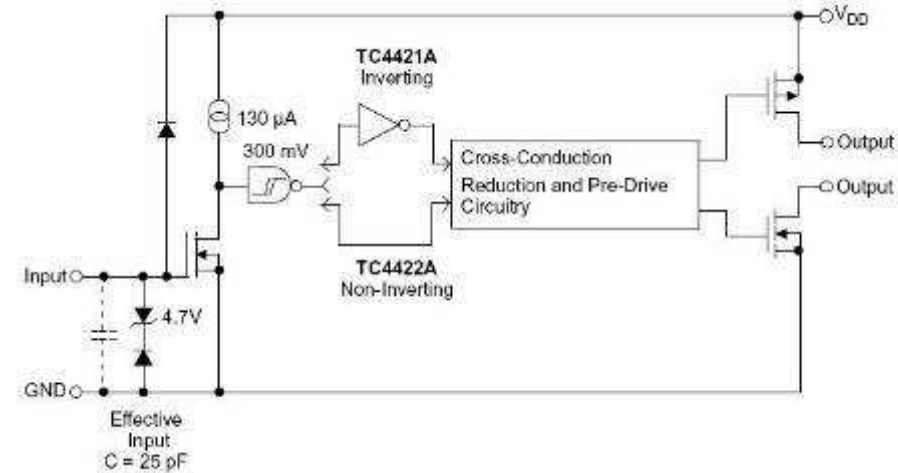

<< [BACK](#)

MCP14A0901/2

9A MOSFET Driver with Low Threshold Input and Enable

Features:

- High Peak Output Current: 9.0A (typical)
- Wide Input Supply Voltage Operating Range: - 4.5V to 18V
- Low Shoot-Through/Cross-Conduction Current in Output Stage
- High Capacitive Load Drive Capability: -10,000 pF in 24 ns (typical)
- Short Delay Times: 27 ns (tD1), 27 ns (tD2) (typical)
- Low Supply Current: 360 μ A (typical)
- Low-Voltage Threshold Input and Enable with Hysteresis
- Latch-Up Protected: Withstands 500 mA Reverse Current
- Space-Saving Packages:
 - 8-Lead MSOP
 - 8-Lead SOIC
 - 8-Lead 2 x 3 TDFN

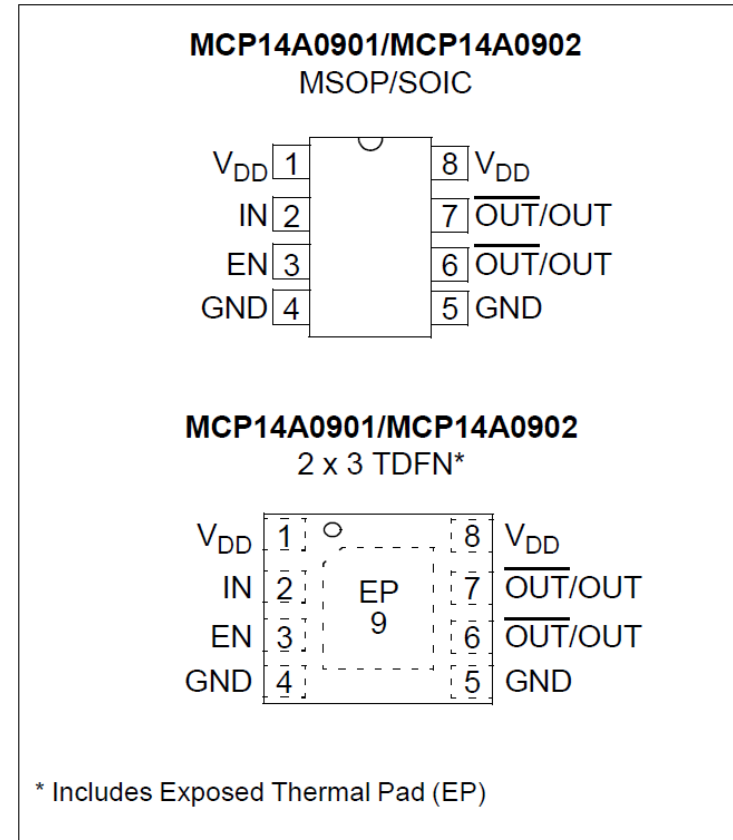

MCP1406/7

6A High-Speed Power MOSFET Drivers



Online
Datasheet

Features:

- High Peak Output Current: 6.0A (typ.)
- Wide Input Supply Voltage Operating Range:
 - 4.5V to 18V
- High Capacitive Load Drive Capability:
 - 2500pF in 20ns
 - 6800pF in 40ns
- Short Delay Times: 40ns (typ.)
- Matched Rise/Fall Times
- Low Supply Current:
 - With Logic '1' Input: 130 μ A (typ.)
 - With Logic '0' Input: 35 μ A (typ.)
- Latch-Up Protected: Will Withstand 1.5A
- Reverse Current
- Logic Input Will Withstand Negative
- Swing up to 5V
- Pin compatible with the TC4420/TC4429
- Space-saving 8-Pin SOIC, PDIP and 8-Pin
- 6x5 DFN Packages
- Recommended for Automotive Design

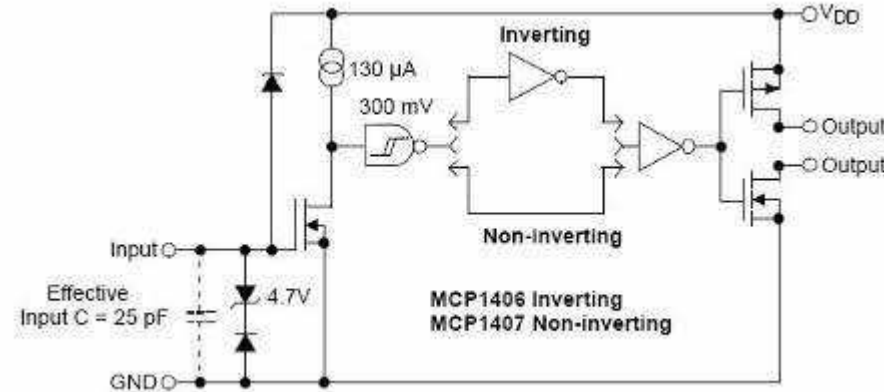

<< BACK

MIC4420/9

6A-Peak Low-Side MOSFET Driver Bipolar/CMOS/DMOS Process

[Online Datasheet](#)

Features:

- CMOS construction
- Latch-up protected: will withstand $>500\text{mA}$ –
- reverse output current
- Logic input withstands negative swing of up to 5V
- Matched rise and fall times of 25ns
- High peak output current at 6A
- Wide operating range from 4.5V to 18V
- High capacitive load drive of 10,000pF
- Low delay time of 55ns typical
- Low delay time 55ns typ.
- Logic high input for any voltage from 2.4V to V_S
- Low equivalent input capacitance (typ.) 6pF
- Low supply current 450 μA with logic 1 input
- Low output impedance 2.5 Ω
- Output voltage swing within 25mV of ground or V_S

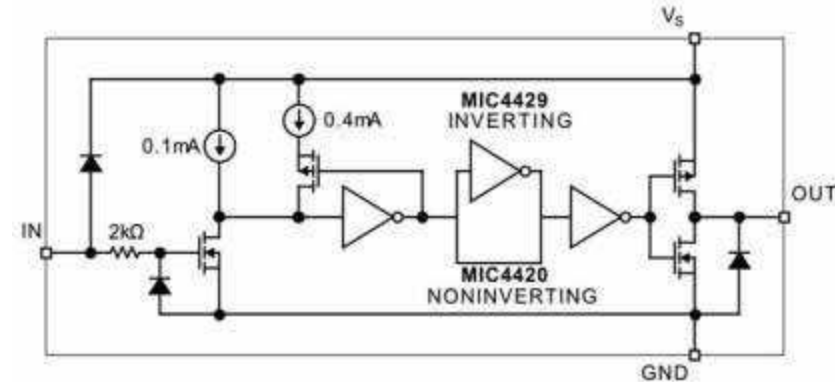

[<< BACK](#)

MCP14A0601/2

6A MOSFET Driver with Low Threshold Input and Enable

Online
Datasheet

Features:

- Peak Output Current: 6 A (typical)
- Wide Supply Voltage Range: 4.5 V to 18 V
- Low Shoot-Through/Cross-Conduction Current –
- in Output Stage
- High Capacitive Load Drive Capability:
 - 2500 pF in 10 ns (typ.)
 - Short Delay: 22 ns (tD1), 22 ns (tD2) (typ.)
- Low Supply Current: 375 μ A (typ.)
- Low Voltage Threshold Input and Enable
 - Hysteresis: 1.2 to 1.6 V
- Latch-Up Protected:
 - Withstands 500 mA Reverse Current
- Small Packages:
 - 8- Lead MSOP
 - 8- Lead SOIC
 - 8- Lead 2x3 TDFN

Package Types

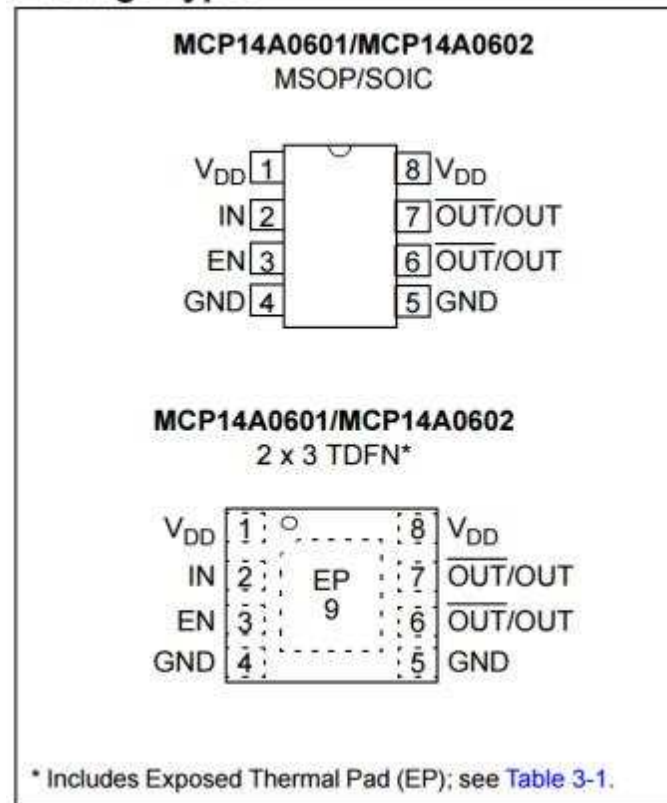

<< BACK

MCP14A0451/2

4.5A MOSFET Driver with Low Threshold Input and Enable

Online
Datasheet

Features:

- Peak Output Current: 4.5 A (typical)
- Wide Supply Voltage Range: 4.5 V to 18 V
- Low Shoot-Through/Cross-Conduction –
– Current in Output Stage
- High Capacitive Load Drive Capability:
 - 2200 pF in 9.5 ns (typ.)
 - Short Delay: 16 ns (tD1), 19.5 ns (tD2) –
– (typ.)
- Low Supply Current: 355 μ A (typ.)
- Low Voltage Threshold Input and Enable
 - Hysteresis: 1.2 to 1.6 V
- Latch-Up Protected:
 - Withstands 500 mA Reverse Current
- Small Packages:
 - 8- Lead MSOP
 - 8- Lead SOIC
 - 8- Lead 2x2 WDFN

Package Types

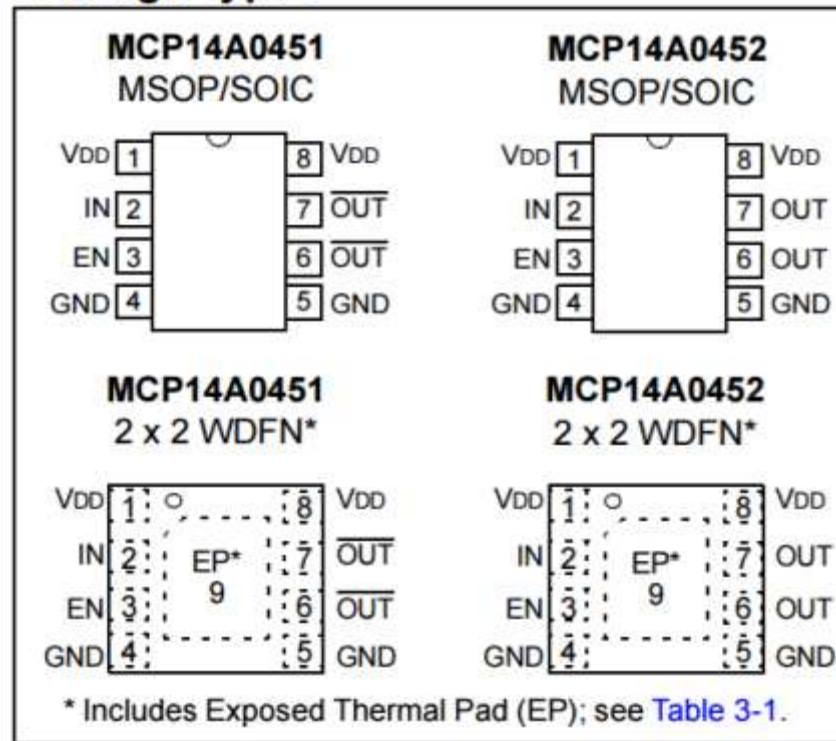

<< BACK

MCP14A0301/2

3A MOSFET Driver with Low Threshold Input and Enable

Online
Datasheet

Features:

- Peak Output Current: 3.0 A (typical)
- Wide Supply Voltage Range: 4.5 V to 18 V
- Low Shoot-Through/Cross-Conduction –
- Current in Output Stage
- High Capacitive Load Drive Capability:
 - 1800 pF in 13 ns (typ.)
 - Short Delay: 15 ns (tD1), 18 ns (tD2) –
- (typ.)
- Low Supply Current: 360 μ A (typ.)
- Low Voltage Threshold Input and Enable with Hysteresis
- Latch-Up Protected:
 - Withstands 500 mA Reverse Current
- Small Packages:
 - 8- Lead MSOP
 - 8- Lead SOIC
 - 8- Lead 2x2 WDFN

Package Types

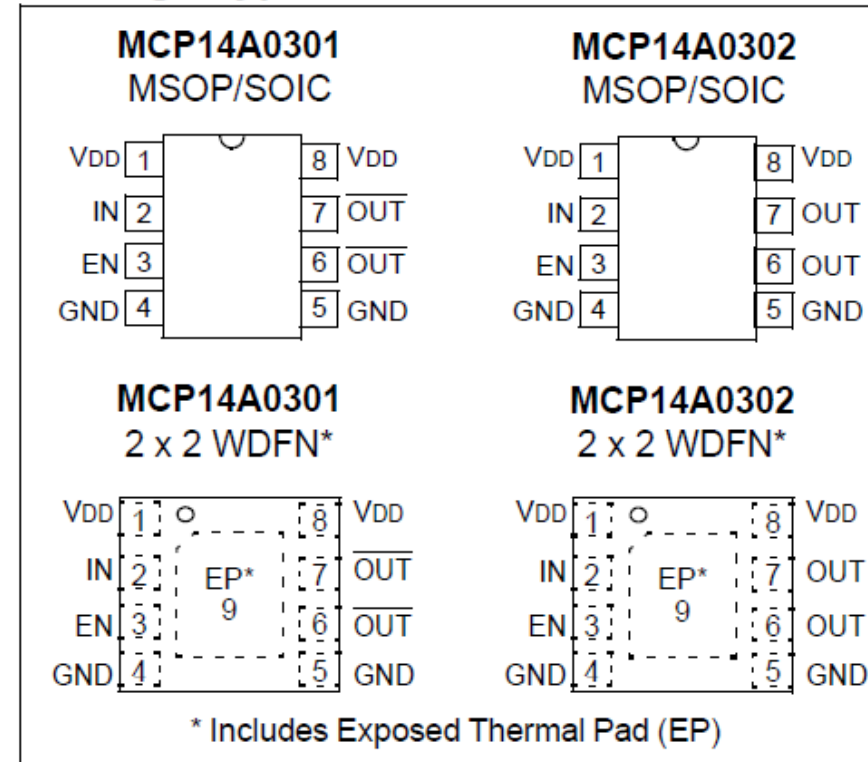

<< BACK

MIC4414/5

1.5A 4.5V to 18V Low-Side MOSFET Driver

Online
Datasheet

Features:

- Ultra-small 4-pin 1.2mm x 1.2mm thin QFN –
- package
- +4.5V to +18V operating supply voltage range
- 1.5A peak current
 - 3.5Ω output resistance at 18V
 - 9Ω output resistance at 5V
- Low steady-state supply current
 - 77μA control input low
 - 445μA control input high
- 12ns rise and fall times into 1000pF load
- MIC4414 (non-inverting)
- MIC4415 (inverting)
- -40°C to +125°C junction temperature
- MIC4414 (non-inverting)
- MIC4415 (inverting)

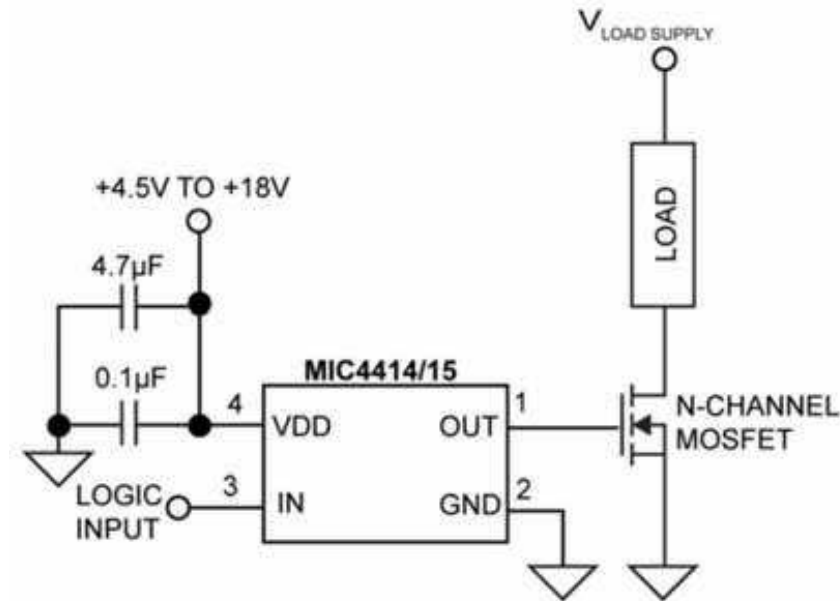

<< BACK

MCP1415/6

Dual Input Synchronous MOSFET Driver



Online Datasheet

Features:

- High Peak Output Current:
 - 1.5A (typ.)
- Wide Input Supply Voltage Operating Range:
 - 4.5V to 18V
- Low Shoot-Through/Cross-Conduction - Current in Output Stage
- High Capacitive Load Drive Capability:
 - 470pF in 13ns (typ.)
 - 1000pF in 20ns (typ.)
- Short Delay Times: 41ns (t_{D1}), 48ns (t_{D2}), (typ.)
- Low Supply Current:
 - With Logic '1' Input: 0.65mA (typ.)
 - With Logic '0' Input: 0.1mA (typ.)
- Latch-Up Protected: Will Withstand 500mA – Reverse Current
- Logic Input Withstands Negative Swing up to 5V
- Space-saving 5-SOT-23 Package
- Recommended for Automotive Design

Functional Block Diagram

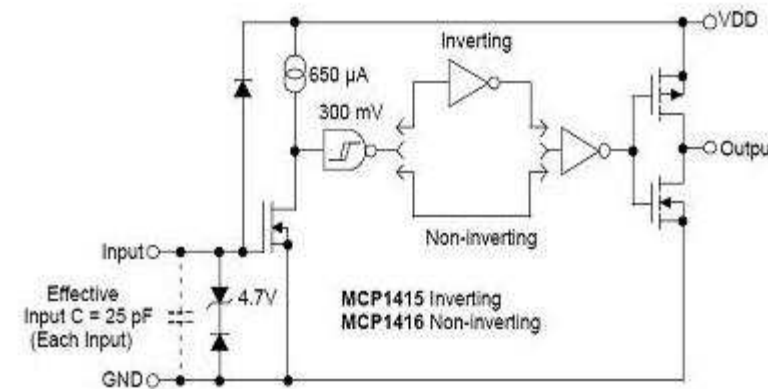

Note: Unused inputs should be grounded.

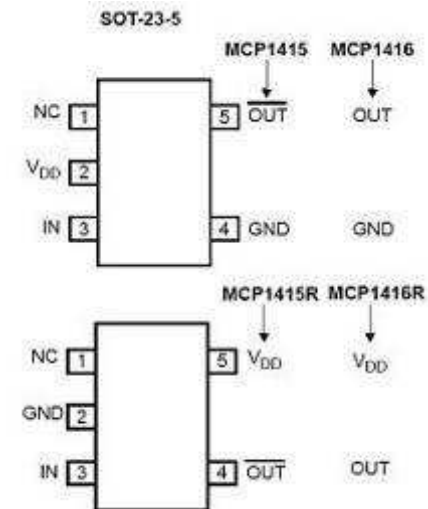

<< BACK



MCP14A0151/2

1.5A MOSFET Driver with Low Threshold Input And Enable

[Online Datasheet](#)

Features:

- Peak Output Current: 1.5 A (typical)
- Wide Supply Voltage Range: 4.5 V to 18 V
- Low Shoot-Through/Cross-Conduction Current –
- in Output Stage
- High Capacitive Load Drive Capability:
 - 1000 pF in 11.5 ns (typ.)
 - Short Delay: 33 ns (t_{D1}), 24 ns (t_{D2}) (typ.)
- Low Supply Current: 375 μ A (typ.)
- Low Voltage Threshold Input and Enable
 - Hysteresis: 1.2 to 1.6 V
- Latch-Up Protected:
 - Withstands 500 mA Reverse Current
- Small Packages: 6-lead SOT-23 and 2x2 DFN

Functional Block Diagram

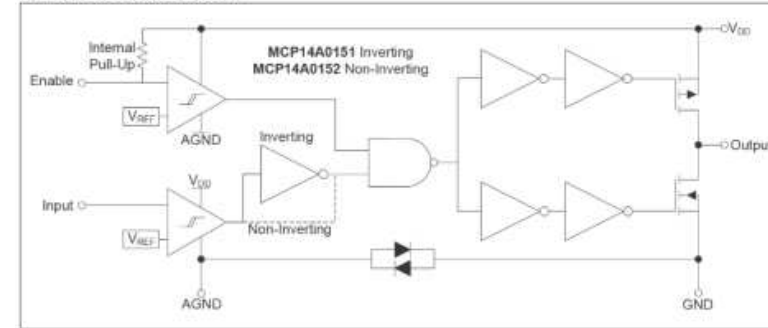

MIC4416/7

IttyBitty® Low-Side MOSFET Driver

Online
Datasheet

Features:

- +4.5V to +18V operation
- Low steady-state supply current
 - 50µA typical, control input low
 - 370µA typical, control input high
- 1.2A nominal peak output
 - 3.5Ω typical output resistance at 18V supply
 - 7.8Ω typical output resistance at 5V supply
- Operates in low-side switch circuits
- TTL-compatible input withstands -20V
- ESD protection
- 25mV maximum output offset from supply or ground
- Inverting and noninverting versions

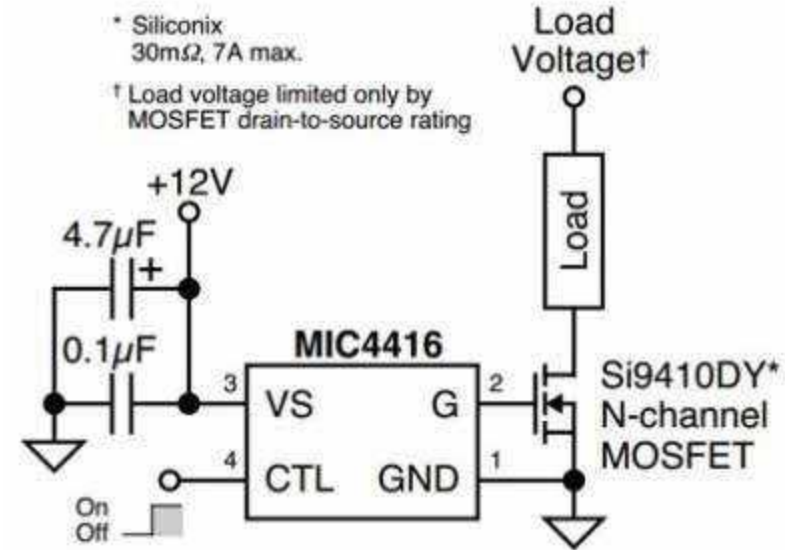

MP1401/02

Tiny 500 mA, High-Speed Power MOSFET Driver



Online
Datasheet

Features:

- High Peak Output Current: 500mA (typ.)
- Wide Input Supply Voltage Operating Range:
 - 4.5V to 18V
- Low Shoot-Through/Cross-Conduction –
 - Current in Output Stage
- High Capacitive Load Drive Capability:
 - 470pF in 19ns (typ.)
 - 1000pF in 34ns (typ.)
- Short Delay Times: 35ns (typ.)
- Matched Rise/Fall Times
- Low Supply Current:
 - With Logic '1' Input – 0.85mA (typ.)
 - With Logic '0' Input – 0.10mA (typ.)
- Latch-Up Protected: Will Withstand 500mA –
 - Reverse Current
- Logic Input Will Withstand Negative Swing –
 - Up To 5V
- Packages: 5-Pin SOT-23
- Recommended for Automotive Design (MCP1401)

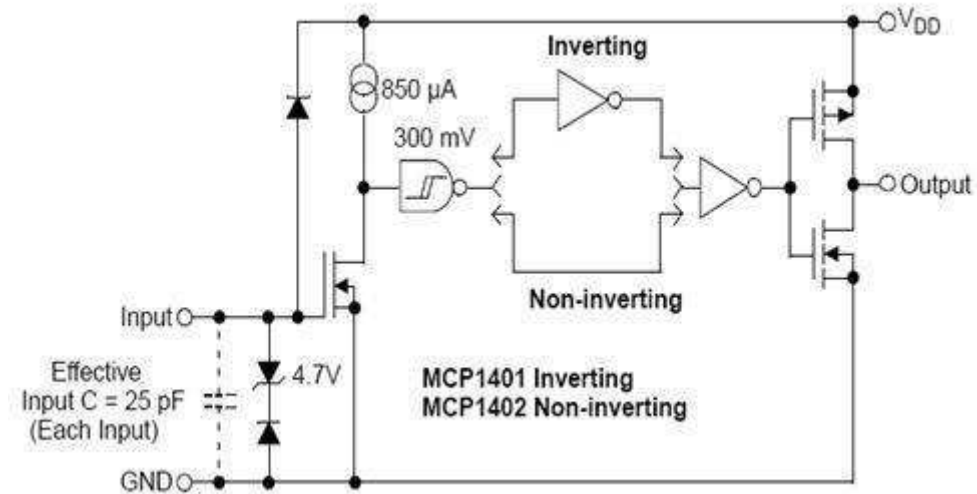

<< [BACK](#)

MCP14A0051/2

0.5A MOSFET Driver with Low Threshold Input And Enable

Online
Datasheet

Features:

- Peak Output Current: 0.5 A (typical)
- Wide Supply Voltage Range: 4.5 V to 18 V
- Low Shoot-Through/Cross-Conduction –
– Current in Output Stage
- High Capacitive Load Drive Capability:
 - 1000 pF in 40 ns (typ.)
 - Short Delay: 33 ns (t_{D1}), 24 ns (t_{D2}) (typ.)
- Low Supply Current: 375 μ A (typ.)
- Low Voltage Threshold Input and Enable
 - Hysteresis: 1.2 to 1.6 V
- Latch-Up Protected:
 - Withstands 500 mA Reverse Current
- Small Packages: 6-lead SOT-23 and 2x2 DFN

Functional Block Diagram

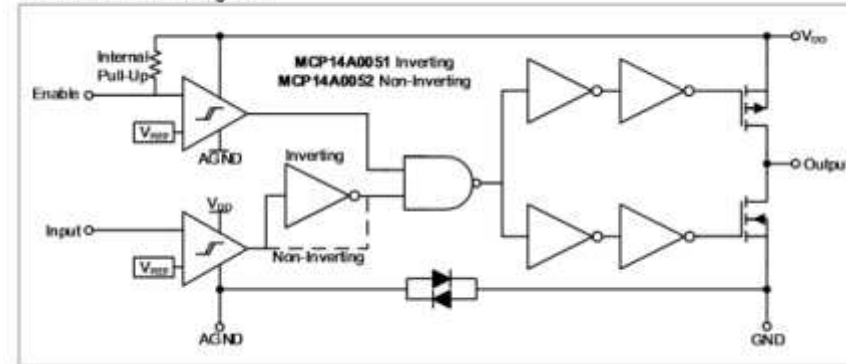

<< BACK

TC1413/N

3A High-Speed MOSFET Drivers

Online
Datasheet

Features:

- High Peak Output Current: 3A
- Latch-Up Protected: Will Withstand –
 - 500mA Reverse Current
- Input Will Withstand Negative Inputs –
 - Up to 5V
- ESD Protected: 4kV
- Wide Operating Range: 4.5V to 16V
- High Capacitive Load Drive Capability:
 - 1800pF in 20ns
- Short Delay Time: 35ns (typ.)
- Matched Delay Times
- Low Supply Current:
 - With Logic '1' Input: 500μA
 - With Logic '0' Input: 100μA
- Low Output Impedance: 2.7Ω
- Pinout Same as TC1410/11/12
- Space Saving 8-Pin MSOP Package

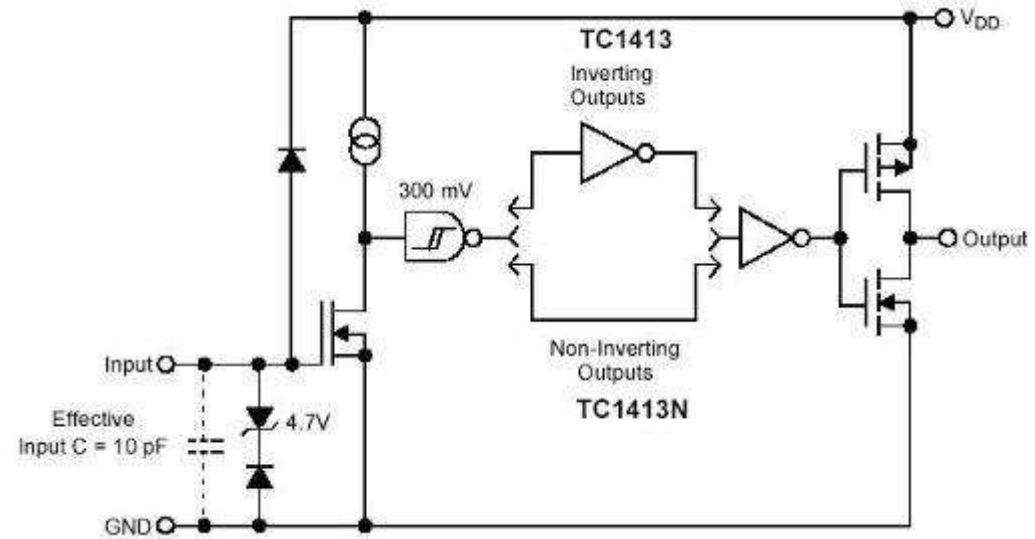

<< BACK

TC1412/N

2A High-Speed MOSFET Drivers

Online
Datasheet

Features:

- High Peak Output Current: 2A
- Latch-Up Protected: Will Withstand –
 - 500mA Reverse Current
- Input Will Withstand Negative –
 - Inputs Up to 5V
- ESD Protected: 4kV
- Wide Operating Range: 4.5V to 16V
- High Capacitive Load Drive Capability:
 - 1000pF in 18ns
- Short Delay Time: 35ns (typ.)
- Matched Delay Times
- Low Supply Current:
 - With Logic '1' Input: 500 μ A (typ.)
 - With Logic '0' Input: 100 μ A (typ.)
- Low Output Impedance: 4 Ω (typ.)
- Pinout Same as TC1410/11/13
- Space Saving 8-Pin MSOP Package

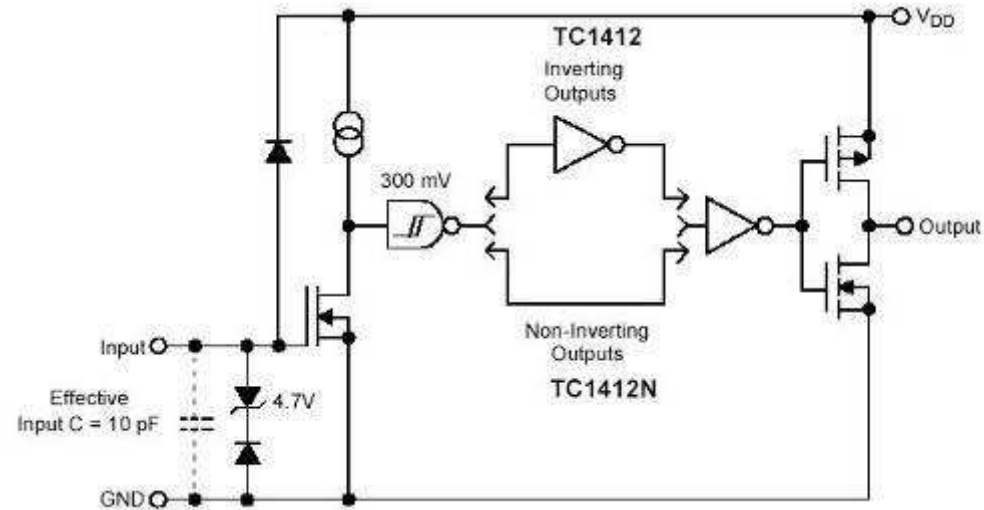

<< BACK

TC1411/N

8-Pin SOIC/MSOP/TSSOP/DIP Evaluation Board

Online
Datasheet

Features:

- Latch-Up Protected: Will Withstand 500mA –
– Reverse Current
- Input Will Withstand Negative Inputs Up to 5V
- ESD Protected: 4kV
- High Peak Output Current: 1A
- Wide Input Supply Voltage Operating
 - Range: 4.5V to 16V
- High Capacitive Load Drive Capability:
 - 1000pF in 25ns (typ.)
- Short Delay Time: 30ns (typ.)
- Matched Delay Times
- Low Supply Current
 - With Logic '1' Input: 500 μ A
 - With Logic '0' Input: 100 μ A
- Low Output Impedance: 8 Ω
- Available in Space-Saving 8-pin MSOP Package
- Pinout Same as TC1410/TC1412/TC1413

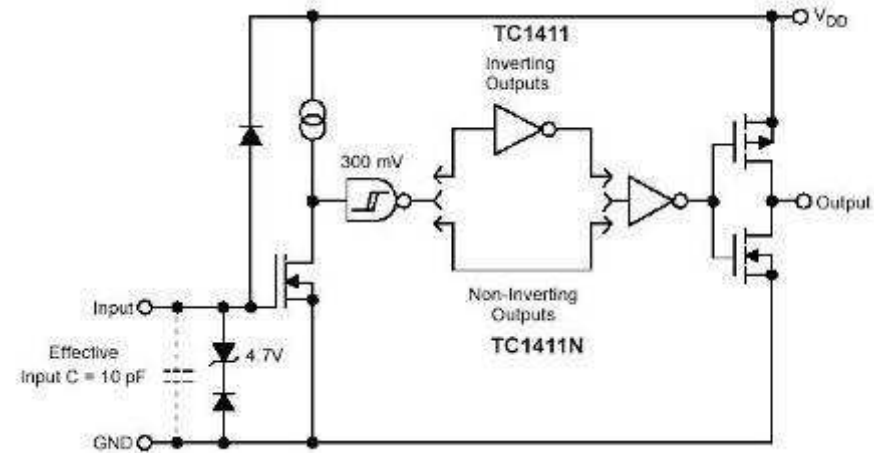

<< BACK

TC1410/N

8-Pin SOIC/MSOP/TSSOP/DIP Evaluation Board

Online
Datasheet

Features:

- Latch-Up Protected:
 - Will Withstand 500mA Reverse Current
- Input Will Withstand Negative Inputs Up to 5V
- ESD Protected: 4kV
- High Peak Output Current: 0.5A
- Wide Input Supply Voltage Operating Range:
 - 4.5V to 16V
- High Capacitive Load Drive Capability:
 - 500pF in 25ns (typ.)
- Short Delay Time: 30ns (typ.)
- Consistent Delay Times With Changes in –
- Supply Voltage
- Matched Delay Times
- Low Supply Current
 - With Logic '1' Input: 500 μ A
 - With Logic '0' Input: 100 μ A
- Low Output Impedance: 16 Ω
- Pinout Same as TC1411/TC1412/TC1413
- Packages: 8-pin MSOP

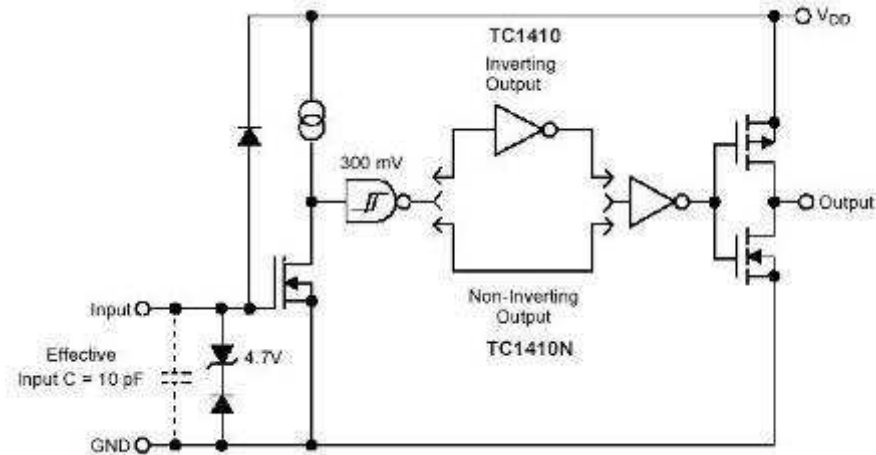

<< BACK

MIC44F18/19/20

6A High Speed MOSFET Drivers in 2mm x 2mm Package

[Online Datasheet](#)

Features:

- 4.5V to 13.2V input operating range
- 6A peak output current
- High accuracy $\pm 5\%$ enable input threshold
- High speed switching capability:
 - 10ns rise time in 1000pF load
 - <15ns propagation delay time
- Flexible UVLO function:
 - 4.2V internally set UVLO
 - Programmable with external resistors
- Latch-up protection to >500mA reverse – current on the output pin
- Enable function
- Thermally enhanced ePad MSOP-8 package option
- Miniature 2mm x 2mm MLF[®]-8 package option
- Pb-free packaging

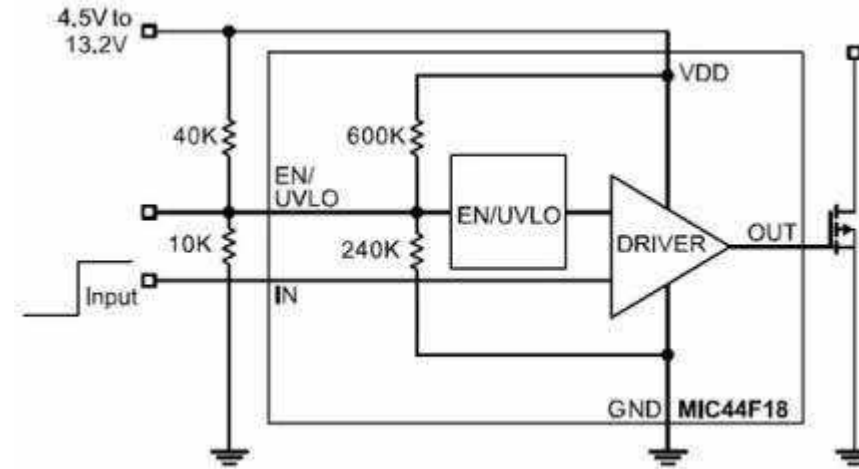

<< BACK

Power CMOS Drivers w/ Voltage Tripler

Features:

- Power Driver With On Board Voltage Booster
- Low I_{DD} : <4mA
- Small Package: 8-Pin PDIP
- Under-Voltage Circuitry
- Fast Rise-Fall Time: <40ns @1000pF
- Below-Rail Input Protection

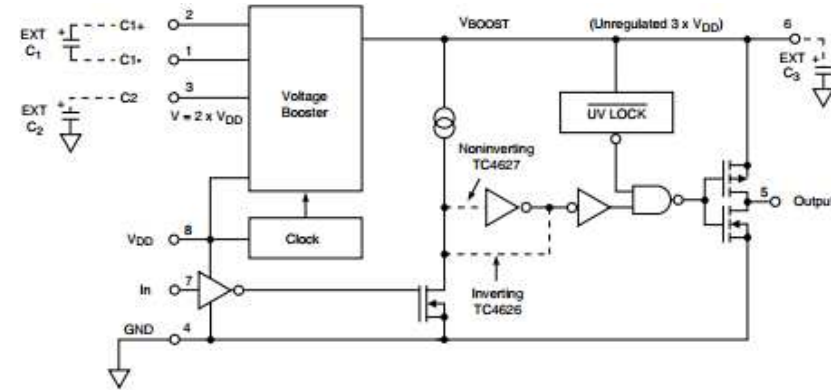

MIC4126/7/8

Dual 1.5A-Peak Low-Side MOSFET Drivers in Advanced Packaging

Online
Datasheet

Features:

- Dual 1.5A-peak drivers
- 4.5V to 20V operating range
- Exposed backside pad packaging reduces heat
 - ePad SOIC-8L ($\theta_{JA} = 58^{\circ}\text{C/W}$)
 - ePad MSOP-8L ($\theta_{JA} = 60^{\circ}\text{C/W}$)
 - 3mm x 3mm MLF[®]-10L ($\theta_{JA} = 60^{\circ}\text{C/W}$)
- Bipolar/CMOS/DMOS construction
- 25mV maximum output offset from supply or ground
- Latch-up protection to >500mA reverse current
- Switches 1000pF in 25ns
- Logic-input threshold independent of supply voltage
- Logic-input protection to -5V
- 6pF typical equivalent input capacitance
- -40°C to +125°C operating junction temperature range

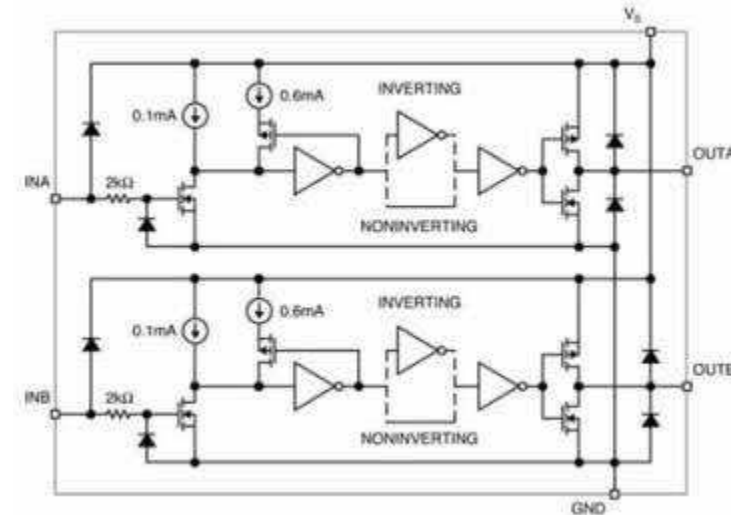

<< BACK

MCP1403/4/5

4.5A Dual High-Speed Power MOSFET Drivers



Online
Datasheet

Features:

- High Peak Output Current: 4.5A
- Wide Input Supply Voltage Operating –
- Range: 4.5V to 18V
- High Capacitive Load Drive Capability:
 - 2200pF in 15ns
- Short Delay Times: 40ns (typ.)
- Low Supply Current:
 - With Logic '1' Input: 1.0mA (max.)
 - With Logic '0' Input: 150 μ A (max.)
- Latch-Up Protected: Will Withstand 1.5A
- Reverse Current
- Logic Input Will Withstand Negative
- Swing up to 5V
- Packages: 8-Pin SOIC, PDIP, 6x5 DFN, and 16-Pin SOIC
- Recommended for Automotive Design (MCP1404/5)

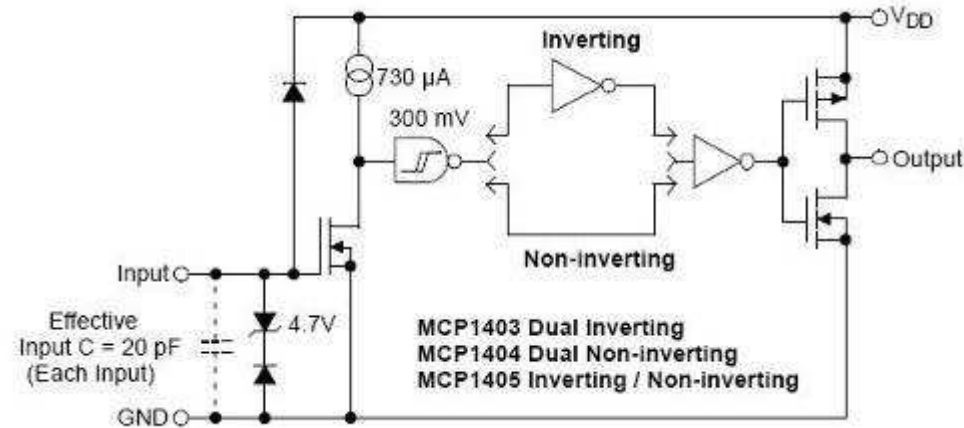

<< BACK

TC4423A/24A/25A

3A Dual High-Speed Power MOSFET Drivers



Online
Datasheet

Features:

- High Peak Output Current: 4.5A
- Wide Input Supply Voltage Operating –
- Range: 4.5V to 18V
- High Capacitive Load Drive Capability:
 - 1800pF in 12ns
- Short Delay Times: 40ns (typ.)
- Matched Rise/Fall Times
- Low Supply Current:
 - With Logic '1' Input: 1.0mA (max.)
 - With Logic '0' Input: 150 μ A (max.)
- Low Output Impedance: 2.5 Ω (typ.)
- Latch-up protected: will withstand –
- 1.5A reverse current
- Logic input will withstand negative –
- swing up to 5V
- Pin compatible with the TC4423/24/25 –
and TC4426A/27A/28A
- Packages: 8-Pin SOIC, 8-Pin 6x5 DFN
- Recommended for Automotive Design (TC4424A)

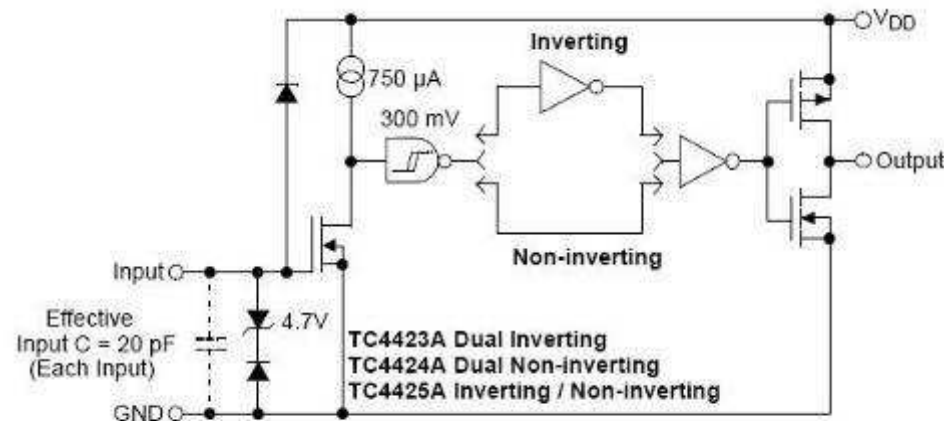

Note 1: Unused inputs should be grounded.

<< BACK

MCP14A0453/4/5

4.5A Dual MOSFET Driver with Low Threshold Input and Enable

Online Datasheet

Features:

- Peak Output Current: 4.5 A
- Wide Supply Voltage Range: 4.5 V to 18 V
- Low Shoot-Through / Cross-Conduction Current in Output Stage
- High Capacitive Load Drive Capability:
 - 2200 pF in 12 ns, (tr and tf, typ.)
 - Short Delay: 16 ns (tD1), 19 ns (tD2, typ.)
- Low Supply Current: 620 μ A (typ.)
- Low Voltage Threshold Input and Enable, with hysteresis, for use with low-voltage MCUs
 - 1.3 V to 1.6 V
- Latch-Up Protected:
 - Withstands 500 mA Reverse Current
- Small Packages:
 - 8- Lead MSOP
 - 8- Lead SOIC
 - 8- Lead 2x3 TDFN

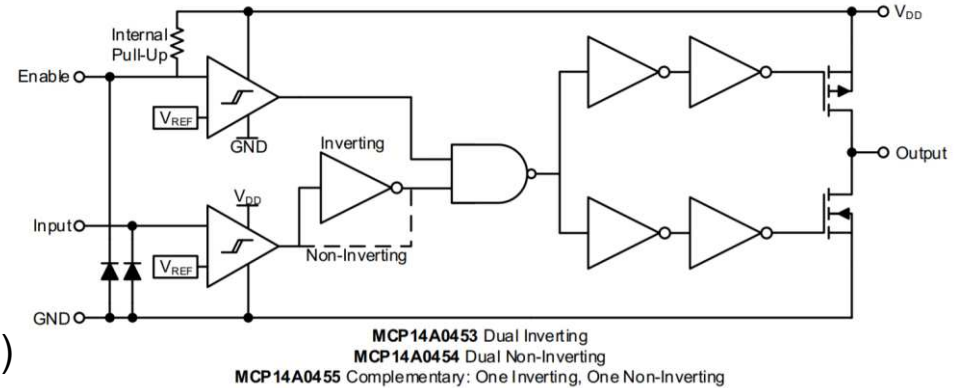

MCP14A0453/4/5 MSOP/SOIC

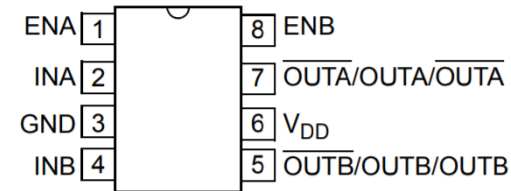

MCP14A0453/4/5 2 x 3 TDFN*

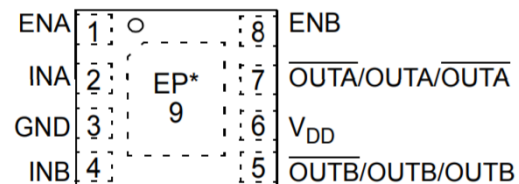

<< BACK



MIC4223/4/5

Dual 4A 4.5V to 18V 15ns Switch Time Low-Side
MOSFET Drivers with Enable

Online
Datasheet

Features:

- 4.5V to 18V supply voltage operating range
- High peak source/sink current
 - $\pm 3\text{A}$ at $V_{DD} = 8\text{V}$
 - $\pm 4\text{A}$ at $V_{DD} = 12\text{V}$
- 15ns/15ns rise and fall times with 2000pF load
- 25ns/35ns (rising/falling) input propagation delay
- 20ns/45ns (rising/falling) enable propagation delay
- Active-high driver enable inputs with 100k Ω pull-ups
- Output latch-up protection to >500mA reverse current
- Industry standard pin out with two package options
 - ePad MSOP-8 ($\theta_{JA} = 60^{\circ}\text{C/W}$)
 - 8-pin SOIC ($\theta_{JA} = 120^{\circ}\text{C/W}$)
- Available in dual-inverting (MIC4223), dual non-inverting –
– (MIC4224) and complementary (MIC4225)
- -40 $^{\circ}\text{C}$ to +125 $^{\circ}\text{C}$ operating junction temperature range

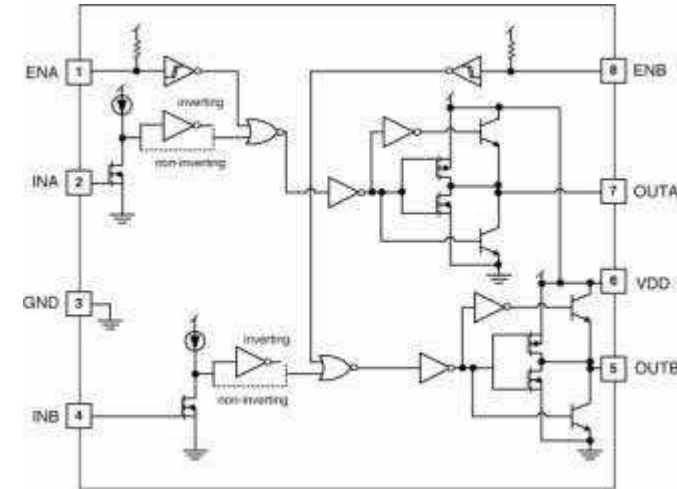

<< BACK

MCP14E3/4/5

4.0A Dual High-Speed Power MOSFET Drivers With Enable



Online
Datasheet

Features:

- High Peak Output Current: 4.0A
- Independent Enable Function for –
 - Each Driver Output
- Low Shoot-Through/Cross –
 - Conduction Current in Output –
 - Stage
- Wide Input Supply Voltage –
 - Operating Range: 4.5V to 18V
- High Capacitive Load Drive Capability:
 - 2200pF in 15ns (typ.)
 - 5600pF in 26ns (typ.)
- Short Delay Times: 50ns (typ.)
- Latch-Up Protected: Will Withstand –
 - 1.5A Reverse Current
- Logic Input Will Withstand Negative –
 - Swing Up To 5V
- Packages: 8-Pin 6x5 DFN, PDIP, SOIC
- Recommended for Automotive Design (MCP14E4)

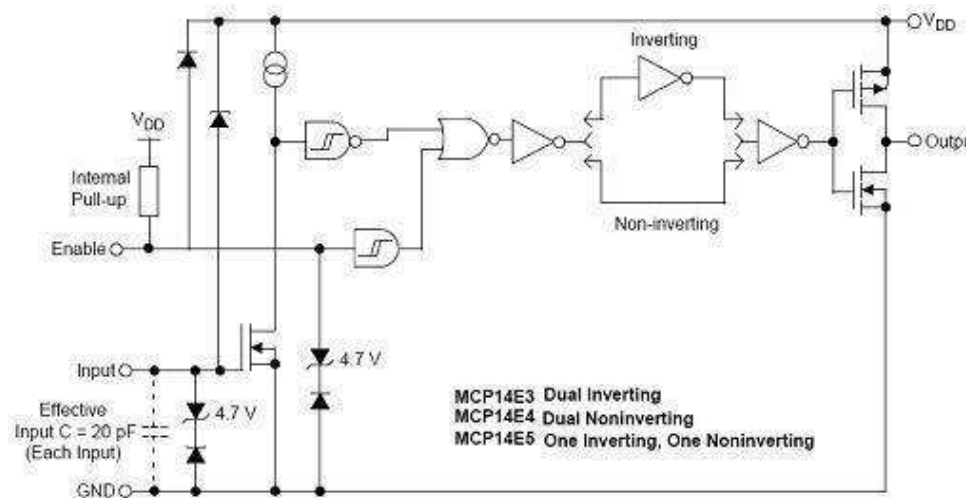

<< BACK

MIC4423/4/5

Dual 3A-Peak Low-Side MOSFET Driver
Bipolar/CMOS/DMOS Process

[Online
Datasheet](#)

Features:

- Reliable, low-power bipolar/CMOS/DMOS –
- construction
- Latch-up protected to >500mA reverse current
- Logic input withstands swing to -5V
- High 3A peak output current
- Wide 4.5V to 18V operating range
- Drives 1800pF capacitance in 25ns
- Short <40ns typical delay time
- Low equivalent 6pF input capacitance
- 3.5mA with logic 1 input
- 350 μ A with logic 0 input
- Low 3.5 Ω typical output impedance
- Output voltage swings within 25mV of ground or VS.
- '426/7/8-, '1426/7/8-, '4426/7/8-compatible pinout
- Inverting, noninverting, and differential configurations

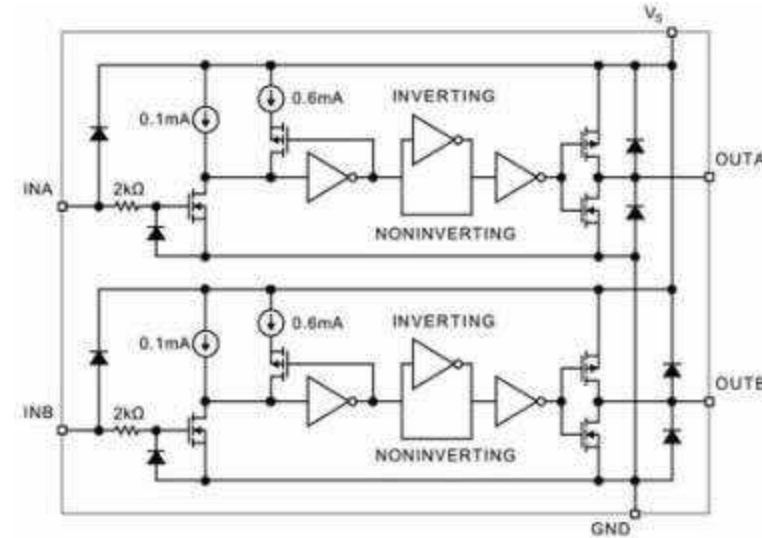

<< BACK

MCP14E9/10/11

3.0A Dual High-Speed Power MOSFET Driver With Enable

Online
Datasheet

Features:

- High peak output Current: 3A (typ.)
- Dual Outputs (E9/10/11):
 - Dual inverting: MCP14E9
 - Dual non-inverting: MCP14E10
 - Complementary outputs: MCP14E11
- Enable Function for each Driver
- Low Shoot-Through/Cross-Conduction -
 - Current Wide Input Operating Range:
 - 4.5v to 18V
- High Capacitive Load drive Capability:
 - 1800 pF in 17 nsec (typ.)
- Short Delay Times: 45 nsec (typ.)
- Latch-up Protected Passed JEDEC –
 - JESD78A
- Input are TTL/CMOS compatible –
 - and will withstand negative swings –
 - Up To 5V
- ESD Protected: 4kV
- Packages: 8-Pin 6x5 DFN, PDIP, SOIC

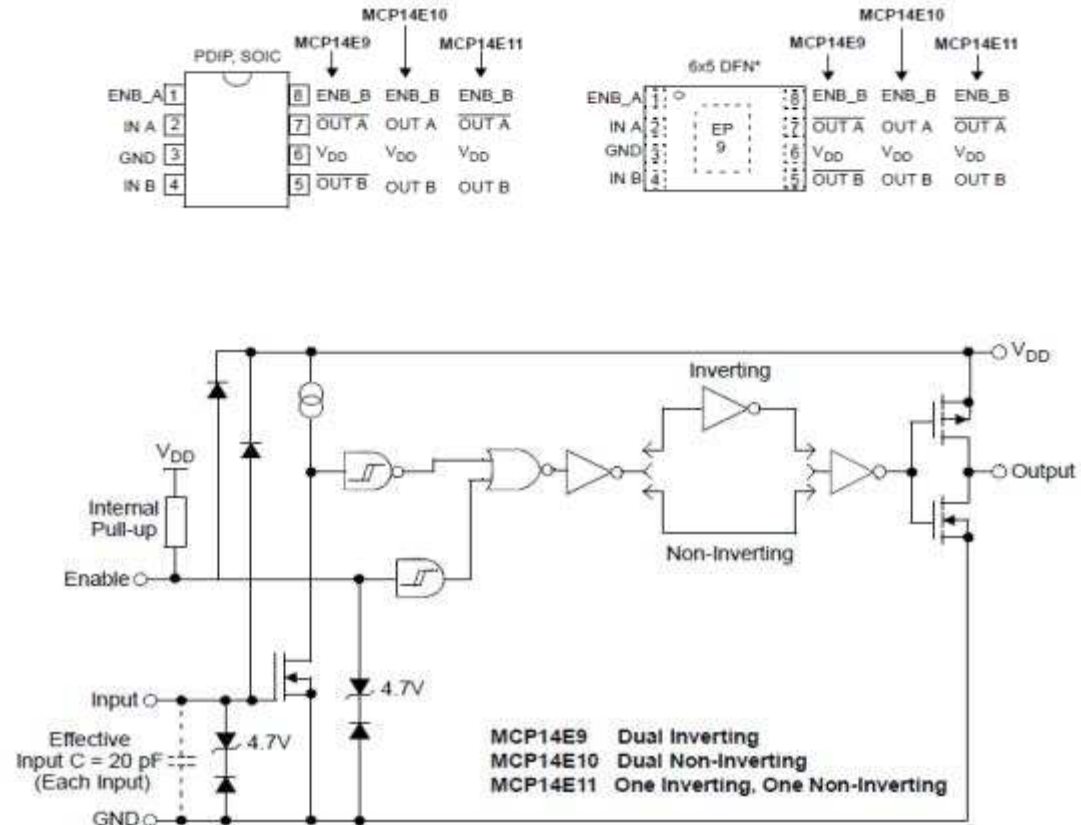

<< BACK

3A Dual High-Speed Power MOSFET Drivers



Online
Datasheet

Features:

- High Peak Output Current: 4.5A
- Wide Input Supply Voltage Operating –
- Range: 4.5V to 18V
- High Capacitive Load Drive Capability:
 - 1800pF in 12ns
- Short Delay Times: 40ns (typ.)
- Matched Rise/Fall Times
- Low Supply Current:
 - With Logic '1' Input: 1.0mA (max.)
 - With Logic '0' Input: 150 μ A (max.)
- Low Output Impedance: 2.5 Ω (typ.)
- Latch-up protected: will withstand –
- 1.5A reverse current
- Logic input will withstand negative –
- swing up to 5V
- Pin compatible with the TC4423/24/25 –
and TC4426A/27A/28A
- Packages: 8-Pin SOIC, 8-Pin 6x5 DFN
- Recommended for Automotive Design (TC4424A)

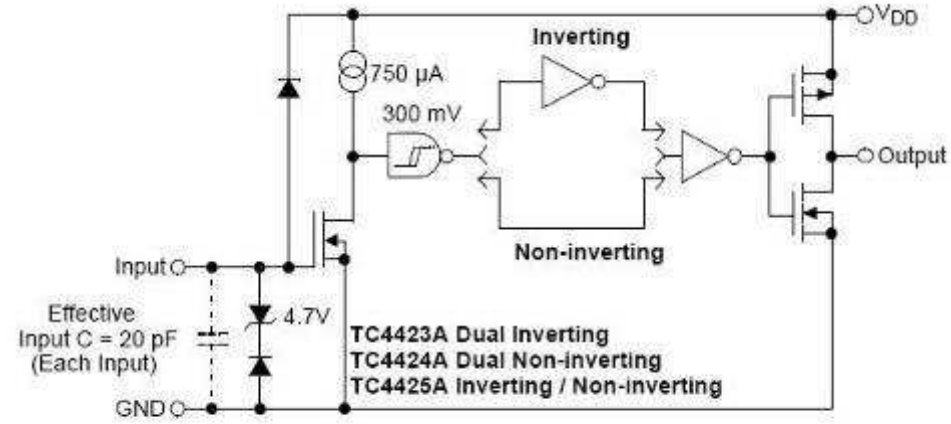

Note 1: Unused inputs should be grounded.

<< BACK

MCP14A0303/4/5

3.0A Dual MOSFET Driver with Low Threshold Input and Enable

[Online Datasheet](#)

Features:

- Peak Output Current: 3.0 A
- Wide Supply Voltage Range: 4.5 V to 18 V
- Low Shoot-Through / Cross-Conduction Current in Output Stage
- High Capacitive Load Drive Capability:
 - 1800 pF in 12 ns, (t_r and t_f , typ.)
 - Short Delay: 17 ns (t_{D1}), 21 ns (t_{D2} , typ.)
- Low Supply Current: 620 μ A (typ.)
- Low Voltage Threshold Input and Enable, with hysteresis, for use with low-voltage MCUs
 - 1.3 V to 1.6 V
- Latch-Up Protected:
 - Withstands 500 mA Reverse Current
- Small Packages:
 - 8- Lead MSOP
 - 8- Lead SOIC
 - 8- Lead 2x3 TDFN

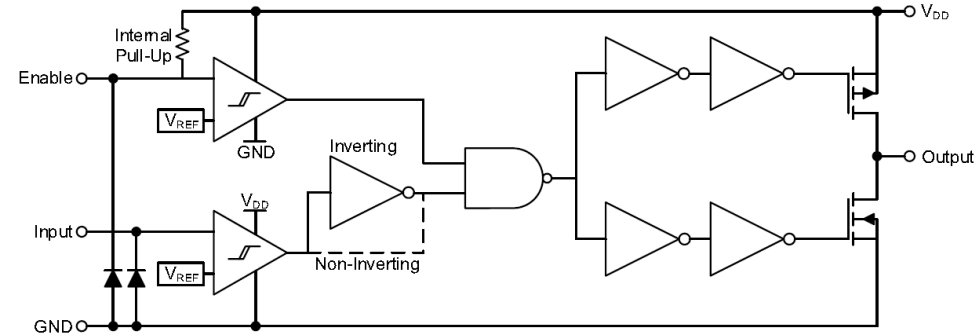

MCP14A0303/4/5

2 x 3 TDFN*

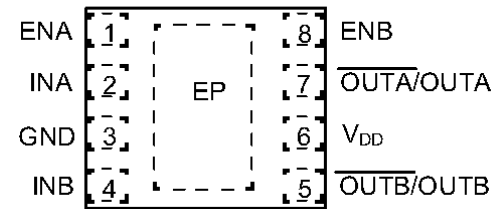

8-pin MSOP/SOIC

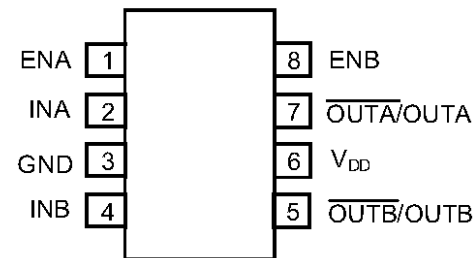

[<< BACK](#)

MCP14E6/7/8

2.0A Dual High-Speed Power MOSFET Driver With Enable

Online
Datasheet

Features:

- High peak output Current: 2A (typ.)
- Dual Outputs:
 - Dual inverting: MCP14E6
 - Dual non-inverting: MCP14E7
 - Complementary outputs: MCP14E8
- Enable Function for each Driver
- Low Shoot-Through/Cross-Conduction –
 - Current in output Stage
- Wide Input Operating Range: 4.5V to 18V
- High Capacitive Load drive Capability:
 - - 1000 pF in 15 nsec (typ.)
- Short Delay Times: 45 nsec (typ.)
- Latch-up Protected Passed JEDEC –
 - JESD78A
- Input are TTL/CMOS compatible and –
 - will withstand negative swings up to 5V
- ESD Protected: 4kV
- Packages: 8-Pin 6x5 DFN, PDIP, SOIC

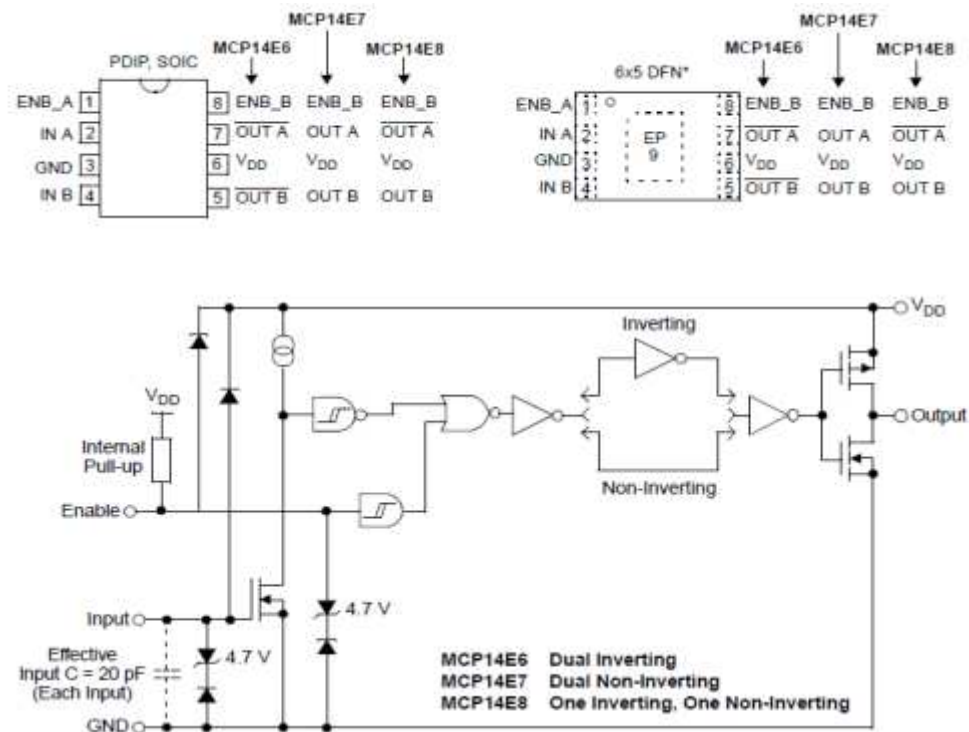

<< BACK

MIC4426/7/8

Dual 1.5A-Peak Low-Side MOSFET Driver

Online
Datasheet

Features:

- Latch-up protection to >500mA reverse current
- 1.5A peak output current
- 4.5V to 18V operating range
- Low quiescent supply current
 - 4mA at logic 1 input
 - 400 μ A at logic 0 input
- Switches 1000pF in 25ns
- 7 Ω output impedance
- <40ns typical delay
- 6pF typical equivalent input capacitance
- 25mV max. output offset from supply or ground
- Replaces MIC426/427/428 and MIC1426/1427/1428
- Dual inverting, dual noninverting, and inverting/ - noninverting configurations
- ESD protection

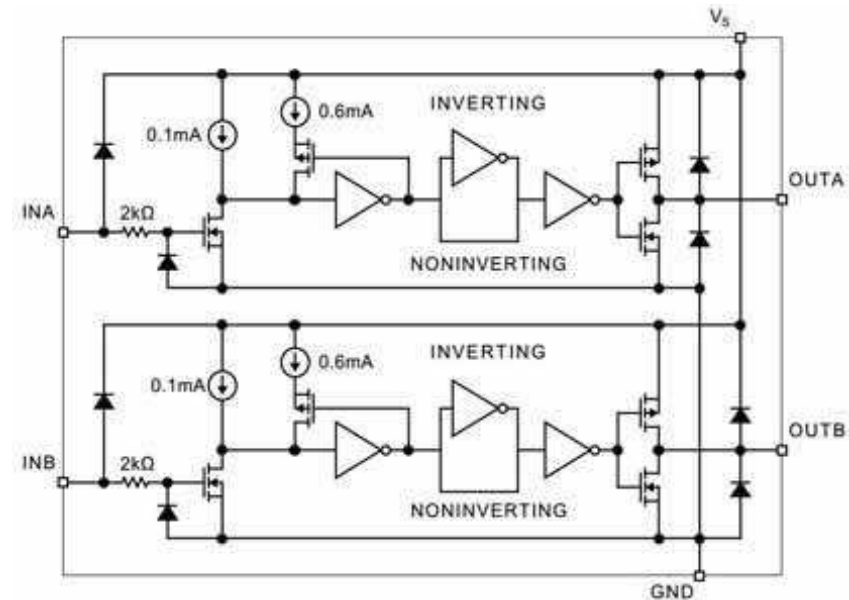

<< BACK

TC4404/5

1.5A Dual Open-Drain MOSFET Drivers

Online
Datasheet

Features:

- Independently-Programmable Rise –
– and Fall Times
- Low Output Impedance: 7Ω (typ.)
- High Speed t_R , t_F :
 - $< 30\text{ns}$ with 1000pF Load
- Short Delay Times: $< 30\text{ns}$
- Wide Operating Range: 4.5V to 18V
- Latch-Up Protected:
 - Will Withstand $> 500\text{mA}$
 - Reverse Current (Either Polarity)
- Input Withstands Negative Swings –
– Up to -5V

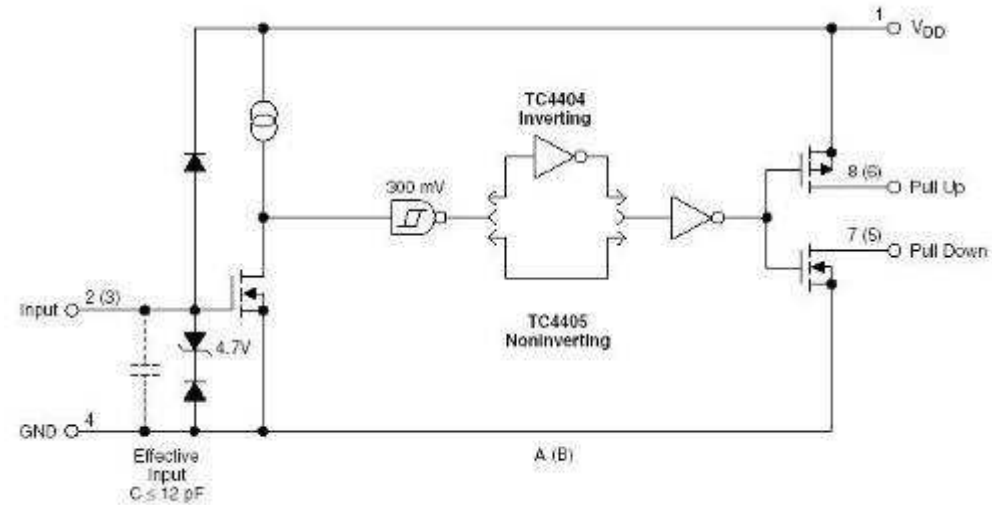

<< BACK

TC4426A/27A/28A

1.5A Dual High-Speed Power MOSFET Drivers



Online
Datasheet

Features:

- High Peak Output Current: 1.5A
- Wide Input Supply Voltage Operating Range:
 - 4.5V to 18V
- High Capacitive Load Drive Capability:
 - 1000pF in 25ns (typ.)
- Short Delay Times: 30ns (typ.)
- Matched Rise, Fall and Delay Times
- Low Supply Current:
 - With Logic '1' Input: 1mA (typ.)
 - With Logic '0' Input: 100 μ A (typ.)
- Low Output Impedance: 7 Ω (typ.)
- Latch-Up Protected: Will Withstand 0.5A –
- Reverse Current
- Input Will Withstand Negative Inputs Up to 5V
- ESD Protected: 4kV
- Pin-compatible with TC426/27/28 and -
- TC4426/27/28
- 8-Pin MSOP and 8-Pin 6x5 DFN Packages
- Recommended for Automotive Design (TC4426A/27/28)

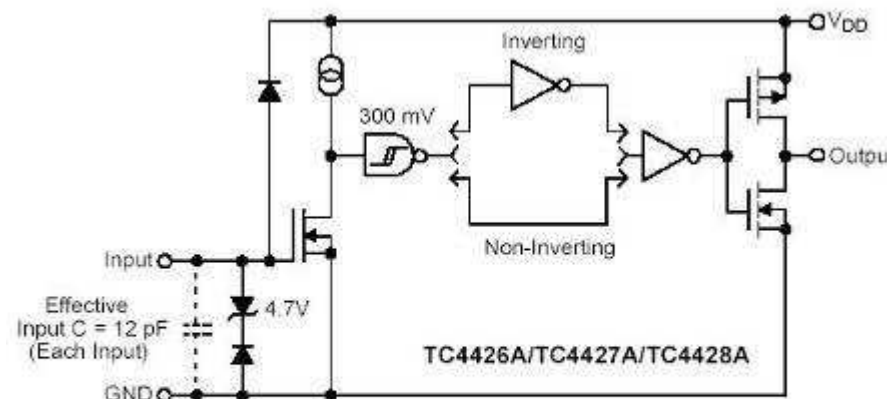

Note 1: TC4426A has two inverting drivers; TC4427A has two non-inverting drivers; TC4428A has one inverting and one non-inverting driver.

2: Ground any unused driver input.

<< BACK

MCP14A0153/4/5

1.5A Dual MOSFET Driver with Low Threshold Input and Enable

Online
Datasheet

Features:

- High Peak Output Current:
 - 1.5A (typical)
- Wide Input Supply Voltage Operating Range:
 - 4.5V to 18V
- Low Shoot-Through/Cross-Conduction –
- Current in Output Stage
- High Capacitive Load Drive Capability:
 - 1000 pF in 11.5 ns (typical)
- Short Delay Times: 25 ns (t_{D1}), 24 ns (t_{D2}) –
- (typical)
- Low Supply Current: 750 μ A (typical)
- Low-Voltage Threshold Input and Enable –
- with Hysteresis
- Latch-Up Protected: Withstands 500 mA –
- Reverse Current
- Space-Saving Packages:
 - 8-Lead MSOP
 - 8-Lead SOIC
 - 8-Lead 2x3 TDFN

Functional Block Diagram

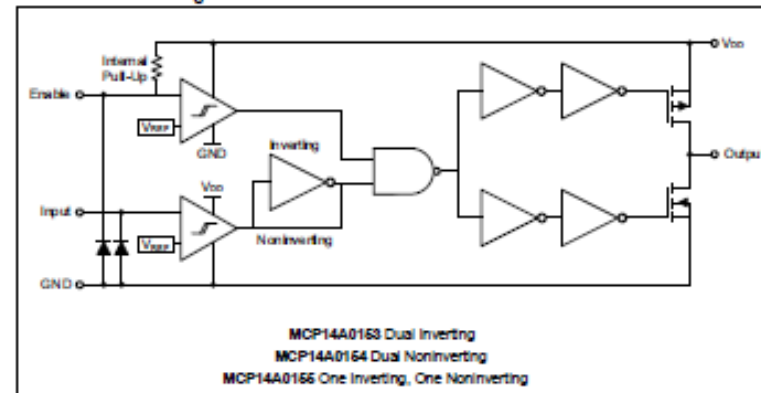

<< BACK

MIC4467/8/9

Quad 1.2A-Peak Low-Side MOSFET Driver

[Online Datasheet](#)

Features:

- Built using reliable, low power CMOS –
– processes
- Latchproof: withstands 500mA inductive –
– kickback
- Three input logic choices
- Symmetrical rise and fall times 25ns
- Short, equal delay times 75ns
- High peak output current 1.2A
- Wide operating range 4.5 to 18V
- Low equivalent input capacitance (typ) 6pF
- Inputs = Logic 1 for any input from 2.4V to VS
- ESD protected

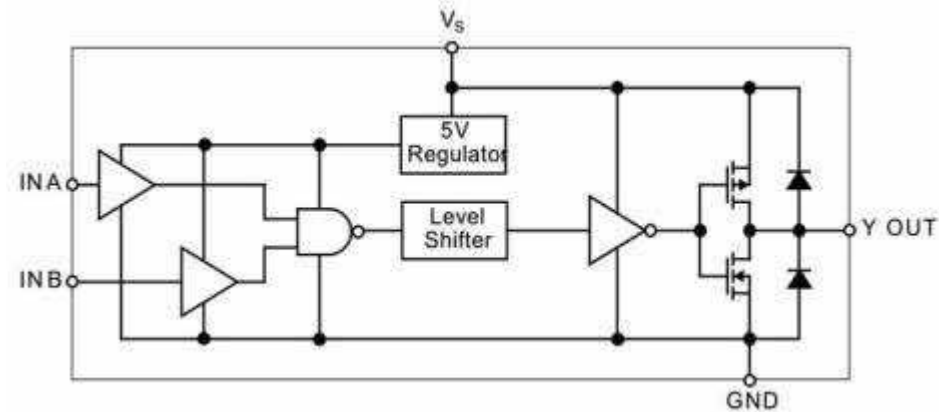

<< BACK

TC4467/8/9

Logic-Input CMOS Quad Drivers

Online
Datasheet

Features:

- High Peak Output Current: 1.2A
- Wide Operating Range: 4.5V to 18V
- Symmetrical Rise/Fall Times: 25ns
- Short, Equal Delay Times: 75ns
- Latch-proof. Will Withstand 500mA –
- Inductive Kickback
- 3 Input Logic Choices: AND / NAND / -
- AND + Inv
- ESD Protection on all pins: 2kV

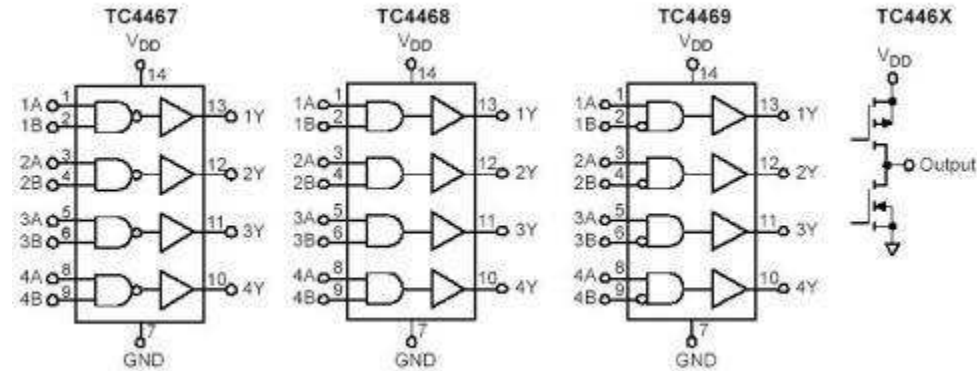

<< BACK

Logic-Input CMOS Quad Drivers

Features:

- High Peak Output Current: 1.2A
- Wide Operating Range: 4.5V to 18V
- Symmetrical Rise/Fall Times: 25ns
- Short, Equal Delay Times: 75ns
- Latch-proof. Will Withstand 500mA – - Inductive Kickback
- 3 Input Logic Choices: AND / NAND / - - AND + Inv
- ESD Protection on all pins: 2kV

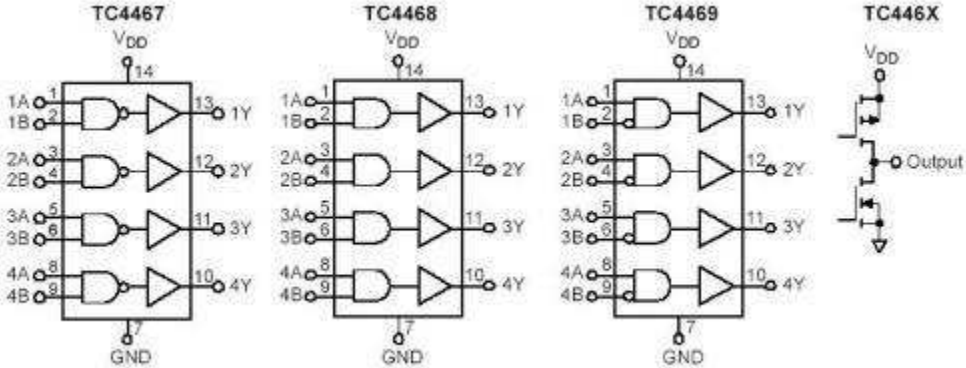

MIC5011

Minimum Parts High- or Low-Side MOSFET Driver

Online
Datasheet

Features:

- +4.75V to +32V operation
- Less than 1 μ A current in the "off" state
- Internal charge pump to drive the gate of an N-channel – power FET above supply
- Available in small outline SOIC packages
- Internal Zener clamp for gate protection
- Minimum external parts count
- Can be used to boost drive to low-side power FETs –
 - operating on logic supplies
- 25 μ s typical turn-on time with optional external –
 - capacitors
- Implements high- or low-side drivers

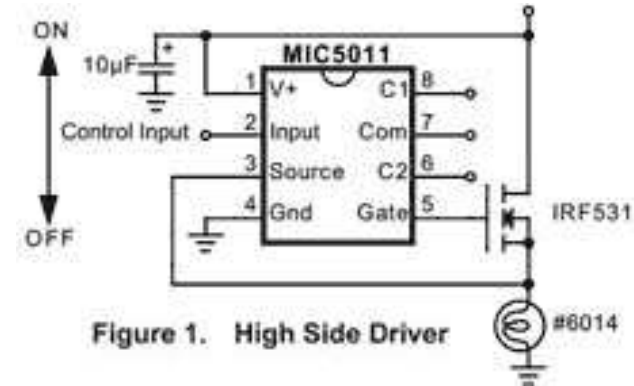

Figure 1. High Side Driver

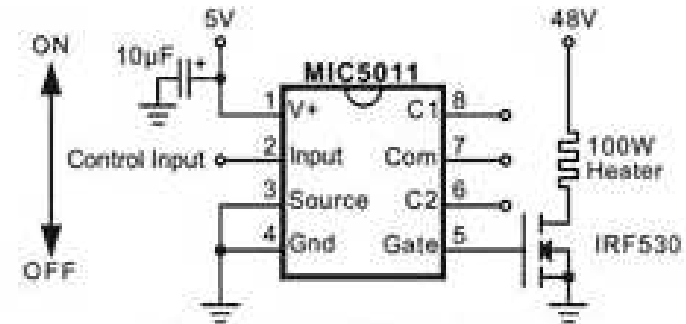

Figure 2. Low Side Driver

<< BACK

MIC5013

Protected High- or Low-Side MOSFET Driver

Online
Datasheet

Features:

- +7.0V to +32V operation
- Less than 1 μ A current in the "off" state
- Internal charge pump to drive the gate of an N – channel power FET above supply
- Available in small outline SOIC packages
- Internal Zener clamp for gate protection
- 60 μ s typical turn-on time to 50% gate overdrive
- Programmable over-current sensing
- Dynamic current threshold for high in-rush loads
- Fault output pin indicates current faults
- Implements high- or low-side switches

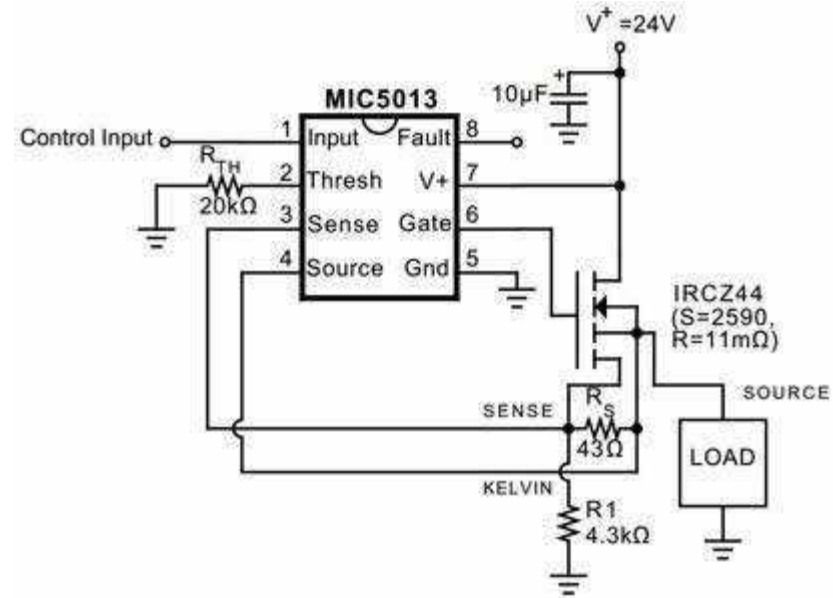

<< BACK

MIC5014/15

Low-Cost High- or Low-Side MOSFET Driver

Online
Datasheet

Features:

- +2.75V to +30V operation
- 100 μ A maximum supply current (5V supply)
- 15 μ A typical off-state current
- Internal charge pump
- TTL compatible input
- Withstands 60V transient (load dump)
- Reverse battery protected to -20V
- Inductive spike protected to -20V
- Overvoltage shutdown at 35V
- Internal 15V gate protection
- Minimum external parts
- Operates in high-side or low-side configurations
- 1 μ A control input pull-off
- MIC5015: Inverting
- MIC5014: Non-inverting versions

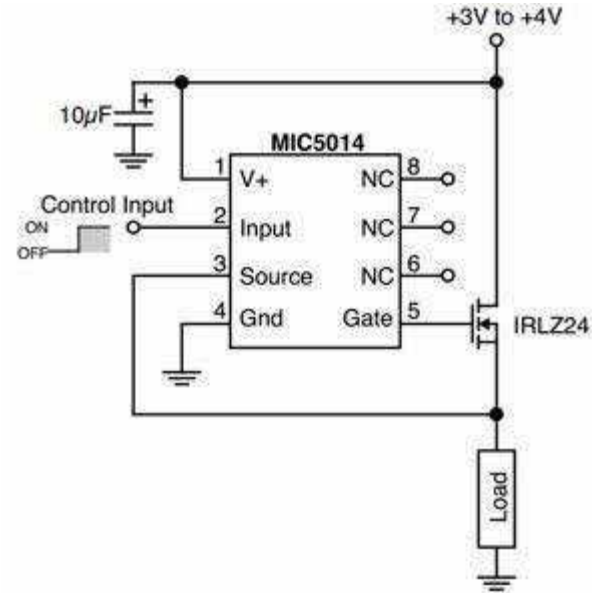

MIC5060

Small High-Side MOSFET Driver

Online
Datasheet

Features:

- 2.75V to 30V operation
- 100 μ A maximum supply current (5V supply)
- 15 μ A typical off-state current
- Internal charge pump
- TTL-compatible input
- Withstands 60V transient (load dump)
- Reverse battery protected to -20V
- Inductive spike protected to -20V
- Overvoltage shutdown at 35V
- Internal 15V gate protection
- Minimum external parts
- Operates in high-side or low-side configurations
- 1 μ A control input pull-off
- Available in 8-pin 3mm x 3mm MLF[®] package

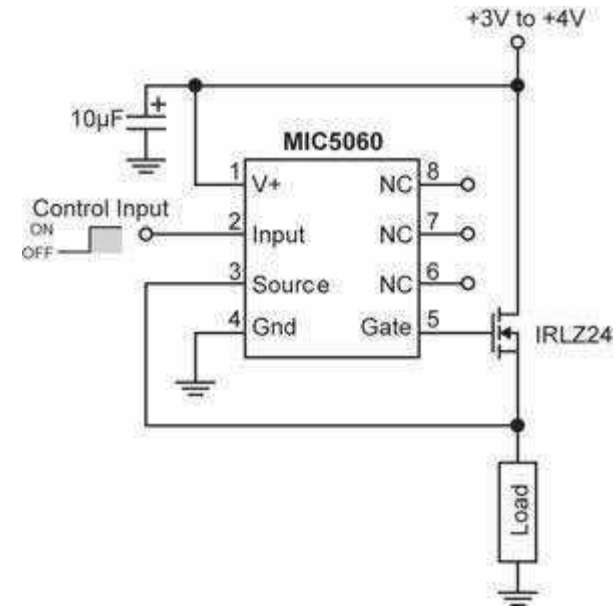

MIC5018

IttyBitty® High-Side MOSFET Driver

Online
Datasheet

Features:

- +2.7V to +9V operation
- 150 μ A typical supply current at 5V supply
- $\leq 1\mu$ A typical standby (off) current
- Charge pump for high-side low-voltage applications
- Internal Zener diode gate-to-ground MOSFET – protection
- Operates in low- and high-side configurations
- TTL compatible input
- ESD protected

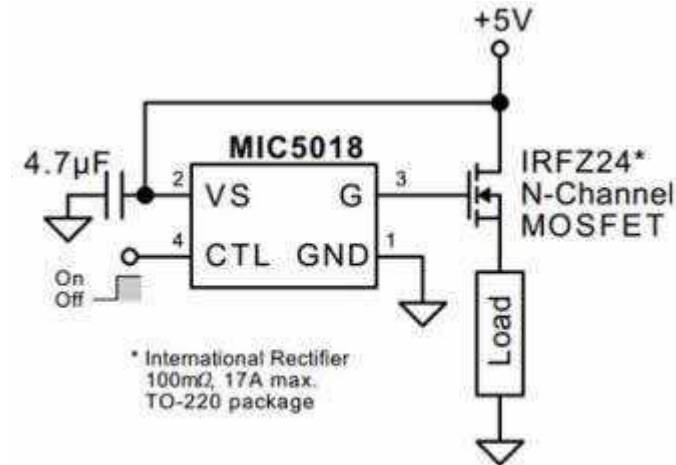

Low-Voltage High-Side Power Switch

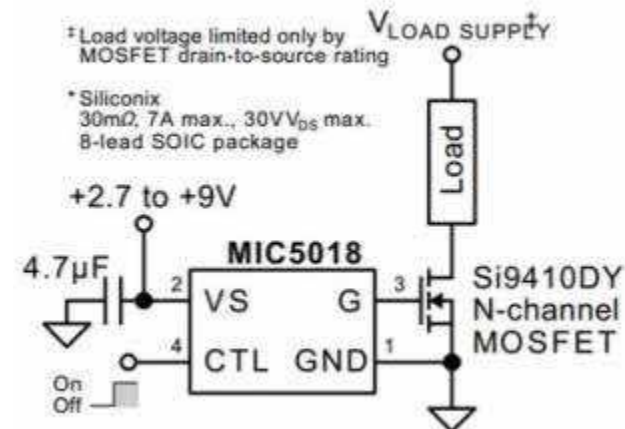

Low-Side Power Switch

<< BACK

MIC5019

Ultra Small High-Side N-Channel MOSFET Driver
with Integrated Charge Pump

Online
Datasheet

Features:

- 4-pin 1.2mm x 1.2mm Thin QFN Package
- +2.7V to +9V supply voltage range
- 16V gate drive at $V_{DD} = 9V$
- 8V gate drive at $V_{DD} = 2.7V$
- Operates in low and high side configurations
- 150 μ A (typical) supply current at $V_{DD} = 5V$
- <1 μ A shutdown supply current
- -40 $^{\circ}$ C to +125 $^{\circ}$ C Junction Temperature Range

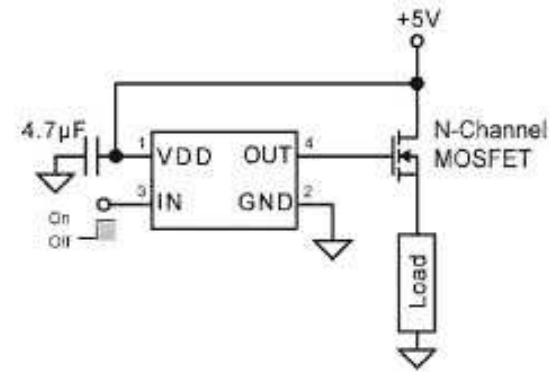

Low-Voltage High-Side Power Switch

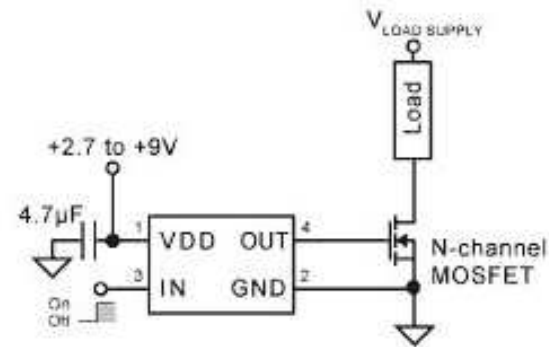

Low-Side Power Switch

<< BACK

MIC4100/1

100V Half Bridge MOSFET Drivers

Online
Datasheet

Features:

- Bootstrap supply max voltage to 118V DC
- Supply voltage up to 16V
- Drives high- and low-side N-Channel MOSFETs –
- with independent inputs
- CMOS input thresholds (MIC4100)
- TTL input thresholds (MIC4101)
- On-chip bootstrap diode
- Fast 30ns propagation times
- Drives 1000pF load with 10ns rise and fall times
- Low power consumption
- Supply under-voltage protection
- 3Ω pull up, 3Ω pull down output resistance
- Space saving SOIC-8L package
- -40°C to +125°C junction temperature range

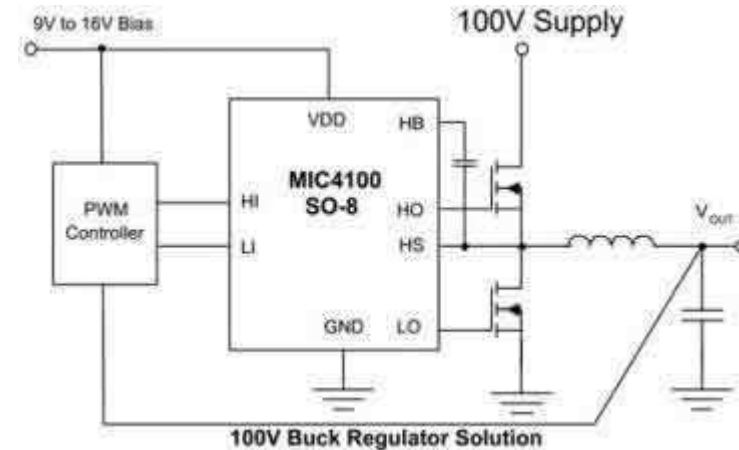

MIC4102

100V Half Bridge MOSFET Driver with Anti-Shoot-Through Protection

Online
Datasheet

Features:

- Drives high- and low-side N-Channel MOSFETs –
- with single input
- Adaptive anti-shoot-through protection
- Low side drive disable pin
- Bootstrap supply voltage to 118V DC
- Supply voltage up to 16V
- TTL input thresholds
- On-chip bootstrap diode
- Fast 30ns propagation times
- Drives 1000pF load with 10ns rise and fall times
- Low power consumption
- Supply under-voltage protection
- 2.5Ω pull up, 1.5Ω pull down output resistance
- Space saving SOIC-8L package
- -40°C to +125°C junction temperature range

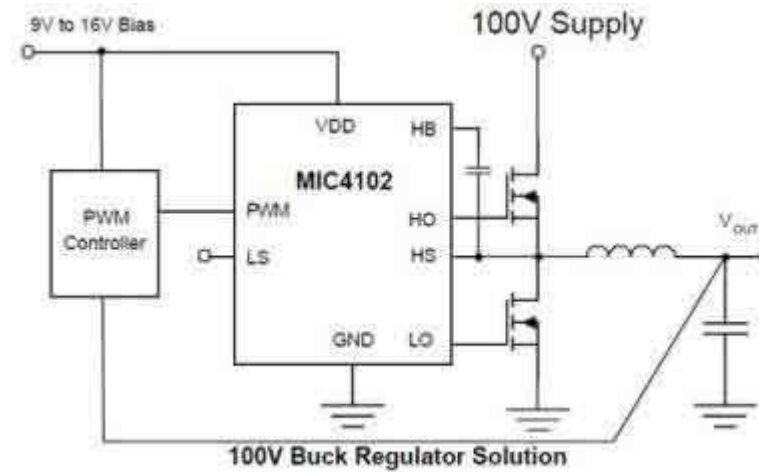

<< BACK

MIC4103/4

100V Half Bridge MOSFET Drivers 3/2A Sinking/Sourcing Current

[Online Datasheet](#)

Features:

- Asymmetrical, low impedance outputs drive –
 - 1000pF load with 10ns rise times and 6ns –
 - fall times
- Bootstrap supply max voltage to 118V DC
- Supply voltage up to 16V
- Drives high- and low-side N-Channel MOSFETs –
 - with independent inputs
- CMOS input thresholds (MIC4103)
- TTL input thresholds (MIC4104)
- On-chip bootstrap diode
- Fast 24ns propagation times
- Low power consumption
- Supply under-voltage protection
- Typical 2.5Ω pull up and 1.25Ω pull down output –
 - driver resistance
- -40°C to +125°C junction temperature range

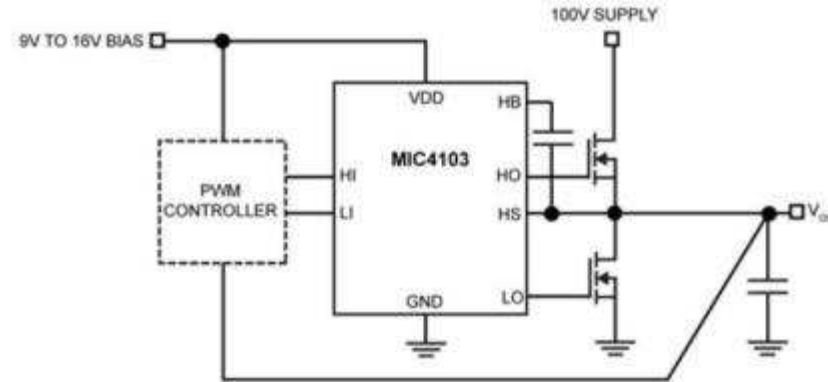

<< BACK

MCP14700

Dual Input Synchronous MOSFET Driver



Online
Datasheet

Features:

- Independent PWM Input Control for –
 - High-Side and Low-Side Gate Drive
- Logic Level Threshold 3.0V TTL Compatible
- Dual Output MOSFET Drive for Synchronous Applications
- High Peak Output Current: 2A (typ.)
- Internal Bootstrap Blocking Device
- +36V BOOT Pin Maximum Rating
- Low Supply Current: 45 μ A (typ.)
- High Capacitive Load Drive Capability:
 - 3300pF in 10.0ns (typ.)
- Under voltage Lockout Protection
- Over temperature Protection
- Packages: 8-Lead SOIC, 8-Lead 3x3 DFN
- Recommended for Automotive Design

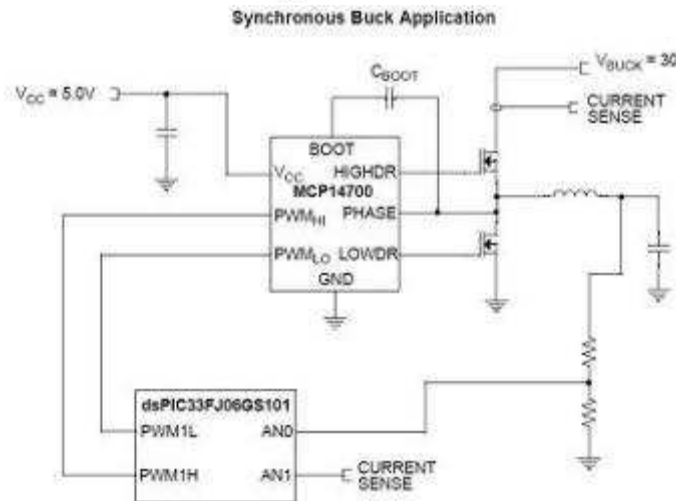
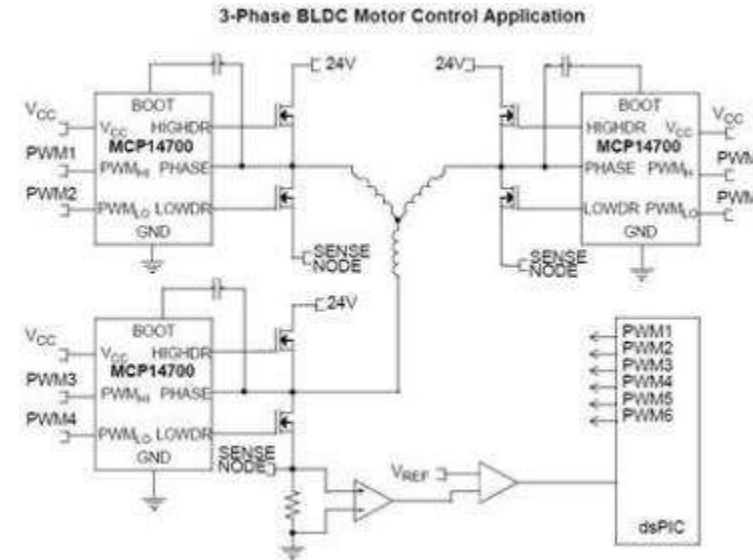
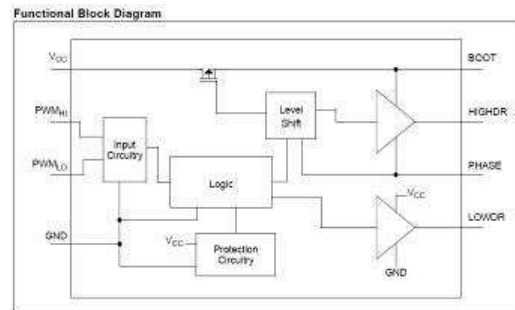

<< BACK to Motor
Drivers

<< BACK to Half
Bridge Drivers

MCP14628

2A Synchronous Buck Power MOSFET Driver

Online
Datasheet

Features:

- Dual Output MOSFET Driver for –
– Synchronous Applications
- High Peak Output Current: 2A (typ.)
- Adaptive Cross Conduction Protection
- Internal Bootstrap Blocking Device
- +36V BOOT Pin Maximum Rating
- Enhanced Light Load Efficiency Mode
- Low Supply Current: 80 μ A (typ.)
- High Capacitive Load Drive Capability:
 - 3300pF in 10ns (typ.)
- Tri-State PWM Pin for Power Stage Shutdown
- Input Voltage Under voltage Lockout Protection
- Space Saving Packages:
 - 8-Lead SOIC, 8-Lead 3x3 DFN

Functional Block Diagram

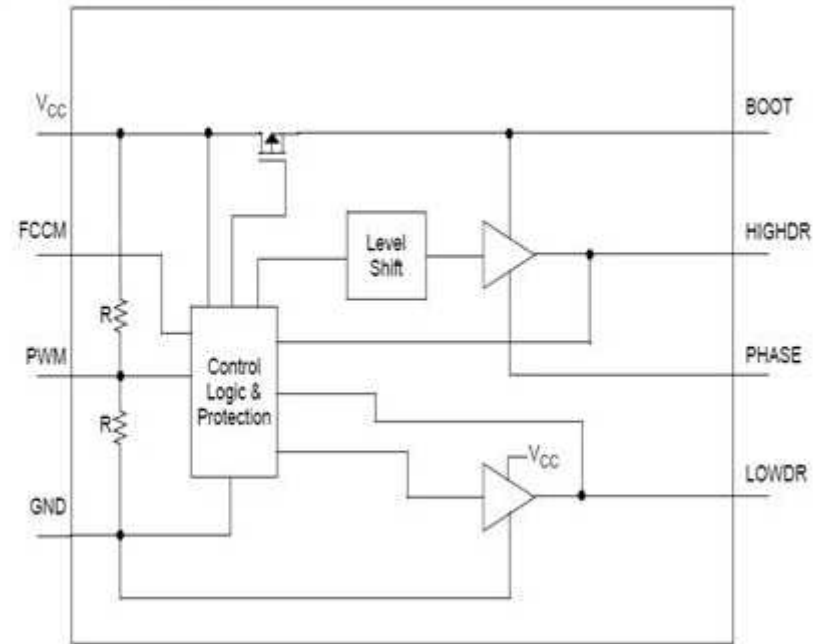

<< BACK to Motor Drivers

<< BACK to Half Bridge
MOSFET Drivers

MIC4600

28V Half-Bridge MOSFET Driver

Online
Datasheet

Features:

- Adjustable dead time circuitry
- Anti-shoot-through protection
- Internal LDO for single supply operation
- Input voltage range: 4.5V to 28V
- Fast propagation delay: 20ns
- Up to 1.5 MHz operation
- Low voltage logic level inputs for μC or –
- FPGA driven power solutions
- Independent inputs for low and high side –
- drivers
- 2Ω gate drive capable of driving 3000pF –
- load with 15ns rise and fall times
- Low 450 μA typical quiescent current
- 3mm x 3mm QFN package
- -40°C to $+125^\circ\text{C}$ junction temperature range

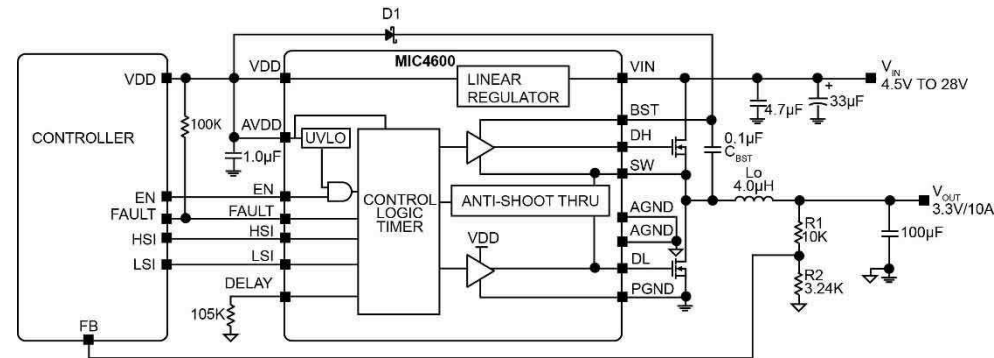

<< BACK

MIC4605

85V Half-Bridge MOSFET Driver, Adaptive Dead Time, Shoot-Thru Protection



Online
Datasheet

Features:

- 5.5V to 16V gate drive supply voltage – range
- Advanced adaptive-dead-time
- Intelligent shoot-through protection
- MIC4605-1: Dual TTL inputs
- MIC4605-2: Single PWM input
- Enable input for on/off control
- On-chip bootstrap diode
- Fast 35ns propagation times
- Drives 1000pF load with 20ns rise – and fall times
- Low power consumption: 135 μ A quiescent current
- Separate high- and low-side under-voltage protection
- -40°C to +125°C junction temperature range

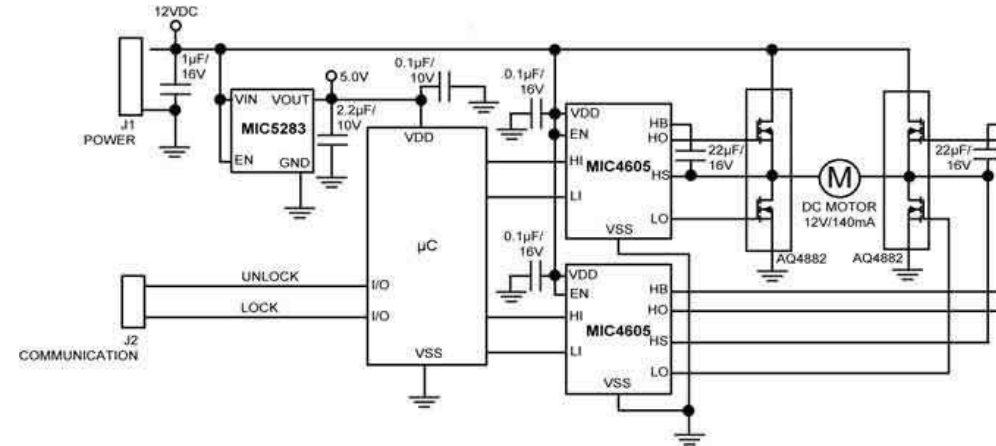

<< BACK to Motor Drivers

<< BACK to Half Bridge
MOSFET Drivers

MIC4604

85V Half Bridge MOSFET Drivers with Programmable Gate Drive

Online
Datasheet

Features:

- 5.5V to 16V gate drive supply voltage range
- Drives high-side and low-side N-Channel –
– MOSFETs with independent inputs
- TTL input thresholds
- On chip bootstrap diode
- Fast 39ns propagation times
- Drives 1000pF load with 20ns rise and –
– fall times
- Low power consumption
- Supplies under-voltage protection
- -40°C to +125°C junction temperature range

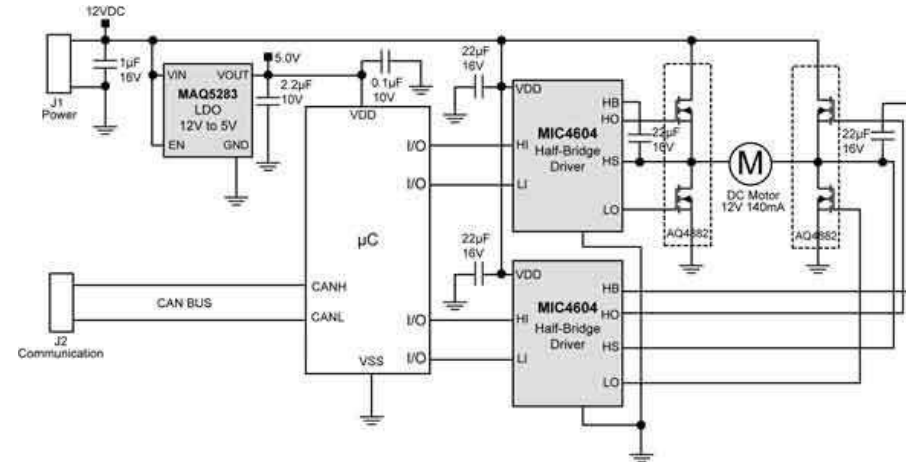

<< BACK to Motor Drivers

<< BACK to Half Bridge
MOSFET Drivers

TC4626/7

Power CMOS Drivers w/ Voltage Tripler

Online
Datasheet

Features:

- Power Driver With On Board Voltage Booster
- Low I_{DD} : <4mA
- Small Package: 8-Pin PDIP
- Under-Voltage Circuitry
- Fast Rise-Fall Time: <40ns @1000pF
- Below-Rail Input Protection

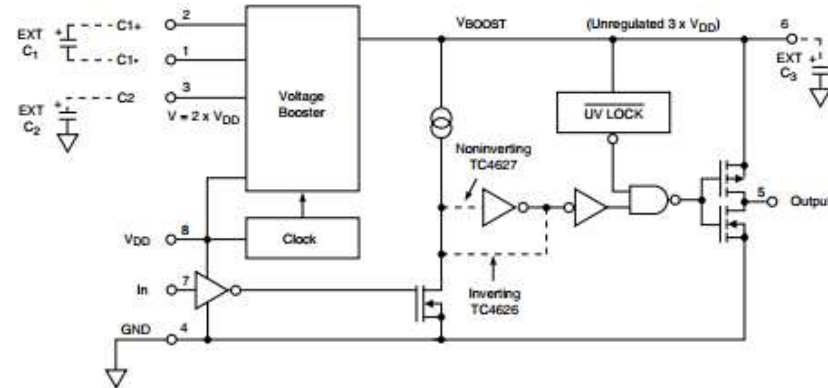

MIC5021

High-Speed High-Side MOSFET Driver

Online
Datasheet

Features:

- 12V to 36V operation
- 550ns rise/fall time driving 2000pF
- TTL compatible input with internal pull-down – resistor
- Overcurrent limit
- Gate to source protection
- Internal charge pump
- 100kHz operation guaranteed over full – temperature and operating voltage range
- Compatible with current sensing MOSFETs
- Current source drive reduces EMI

