



**HESTORE.HU**

elektronikai alkatrész áruház

**EN:** This Datasheet is presented by the manufacturer.

Please visit our website for pricing and availability at [www.hestore.hu](http://www.hestore.hu).

## DUAL BTL/QUAD POWER AMPLIFIER FOR CAR RADIO

- HIGH OUTPUT POWER CAPABILITY:
  - 2 x 37W max./4Ω
  - 2 x 24W/4Ω @14.4V, 1KHz, 10%
  - 4 x 7W/4Ω @14.4V, 1KHz, 10%
  - 4 x 11.5W/2Ω @14.4V, 1KHz, 10%
- MINIMUM EXTERNAL COMPONENTS COUNT:
  - NO BOOTSTRAP CAPACITORS
  - NO BOUCHEROT CELLS
  - INTERNALLY FIXED GAIN (26dB BTL)
- ST-BY FUNCTION (CMOS COMPATIBLE)
- NO AUDIBLE POP DURING ST-BY OPERATIONS
- DIAGNOSTICS FACILITY FOR:
  - CLIPPING
  - OUT TO GND SHORT
  - OUT TO V<sub>S</sub> SHORT
  - SOFT SHORT AT TURN-ON
  - THERMAL SHUTDOWN PROXIMITY

### Protections:

- OUPUT AC/DC SHORT CIRCUIT
  - TO GND
  - TO V<sub>S</sub>

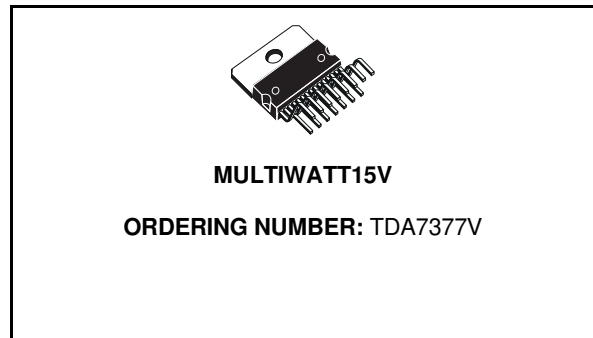

- ACROSS THE LOAD
- SOFT SHORT AT TURN-ON
- OVERRATING CHIP TEMPERATURE WITH SOFT THERMAL LIMITER
- LOAD DUMP VOLTAGE SURGE
- VERY INDUCTIVE LOADS
- FORTUITOUS OPEN GND
- REVERSED BATTERY
- ESD

### BLOCK DIAGRAM

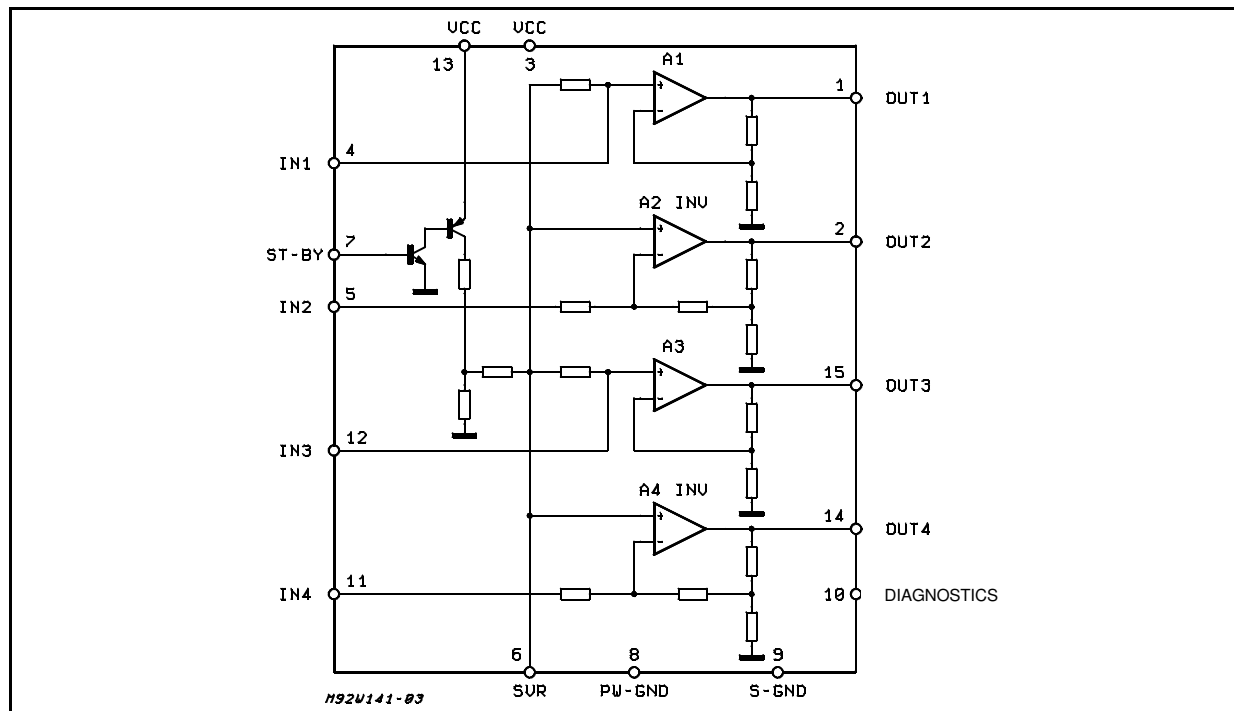

# TDA7377

## DESCRIPTION

The TDA7377 is a new technology class AB car radio amplifier able to work either in DUAL BRIDGE or QUAD SINGLE ENDED configuration. The exclusive fully complementary structure of

the output stage and the internally fixed gain guarantees the highest possible power performances with extremely reduced component count. The on-board clip detector simplifies gain compression operation. The fault diagnostics makes it possible to detect mistakes during car radio set assembly and wiring in the car.

## ABSOLUTE MAXIMUM RATINGS

Symbol	Parameter	Value	Unit
$V_{op}$	Operating Supply Voltage	18	V
$V_S$	DC Supply Voltage	28	V
$V_{peak}$	Peak Supply Voltage (for $t = 50ms$ )	40	V
$I_o$	Output Peak Current (not repetitive $t = 100\mu s$ )	4.5	A
$I_o$	Output Peak Current (repetitive $f > 10Hz$ )	3.5	A
$P_{tot}$	Power Dissipation ( $T_{case} = 85^\circ C$ )	36	W
$T_{stg}, T_j$	Storage and Junction Temperature	-40 to 150	$^\circ C$

## THERMAL DATA

Symbol	Description	Value	Unit
$R_{th j-case}$	Thermal Resistance Junction-case	Max 1.8	$^\circ C/W$

## PIN CONNECTION (Top view)

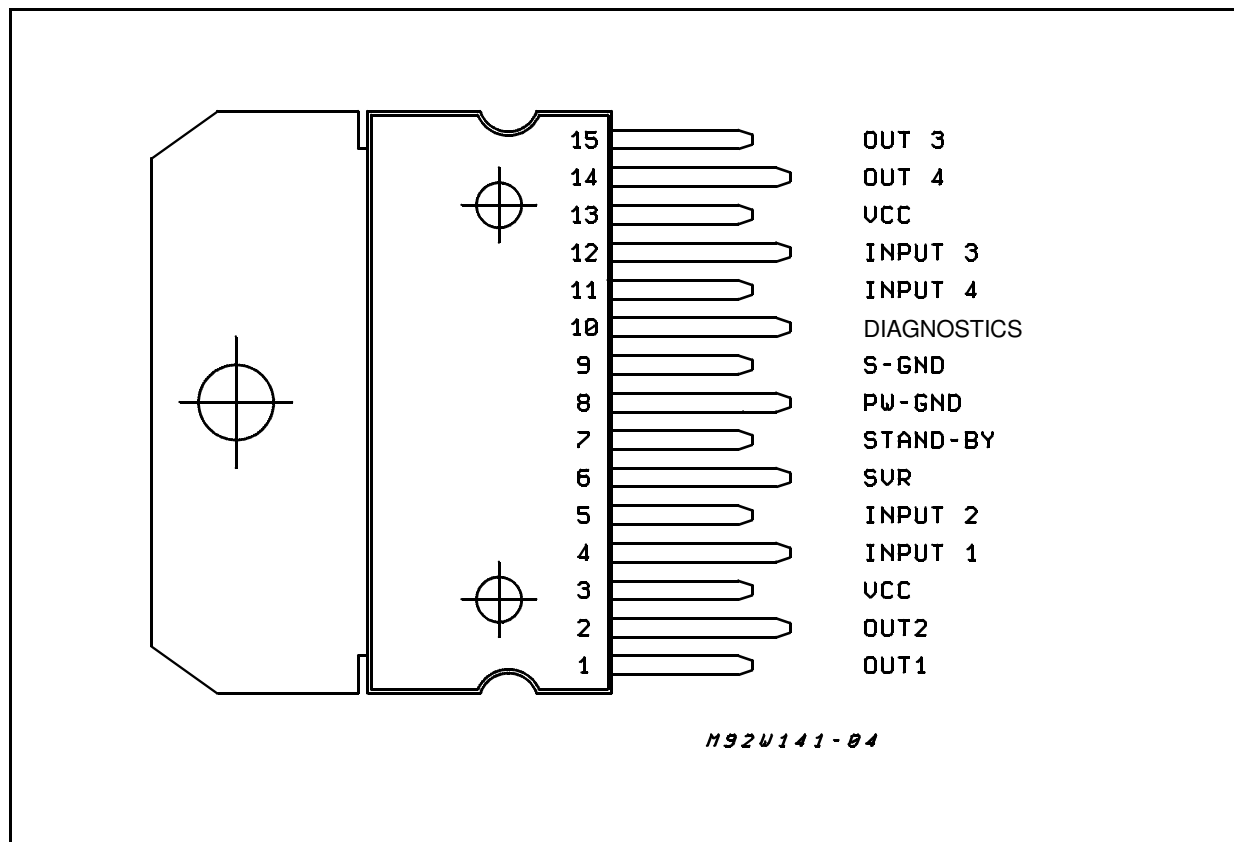

**ELECTRICAL CHARACTERISTICS** (Refer to the test circuit,  $V_S = 14.4V$ ;  $R_L = 4\Omega$ ;  $f = 1KHz$ ;  
 $T_{amb} = 25^\circ C$ , unless otherwise specified)

Symbol	Parameter	Test Condition	Min.	Typ.	Max.	Unit
$V_S$	Supply Voltage Range		8		18	V
$I_d$	Total Quiescent Drain Current	$R_L = \infty$			150	mA
$V_{OS}$	Output Offset Voltage				150	mV
$P_O$	Output Power	THD = 10%; $R_L = 4\Omega$ Bridge Single Ended Single Ended, $R_L = 2\Omega$	21 6.5	24 7 11.5		W W W
$P_{O\ max}$	Max. Output Power (***)	$V_S = 14.4V$ , Bridge	33	37		W
THD	Distortion	$R_L = 4\Omega$ Single Ended, $P_O = 0.1$ to 4W Bridge, $P_O = 0.1$ to 10W		0.02 0.03	0.3	% %
CT	Cross Talk	$f = 1KHz$ Single Ended $f = 10KHz$ Single Ended		70 60		dB dB
		$f = 1KHz$ Bridge $f = 10KHz$ Bridge	55	60		dB dB
$R_{IN}$	Input Impedance	Single Ended Bridge	20 10	30 15		K $\Omega$ K $\Omega$
$G_V$	Voltage Gain	Single Ended Bridge	19 25	20 26	21 27	dB dB
$G_V$	Voltage Gain Match				0.5	dB
$E_{IN}$	Input Noise Voltage	$R_g = 0$ ; "A" weighted, S.E. Non Inverting Channels Inverting Channels		2 5		$\mu V$ $\mu V$
		Bridge $R_g = 0$ ; 22KHz to 22KHz		3.5		$\mu V$
SVR	Supply Voltage Rejection	$R_g = 0$ ; $f = 300Hz$	50			dB
$A_{SB}$	Stand-by Attenuation	$P_O = 1W$	80	90		dB
$I_{SB}$	ST-BY Current Consumption	$V_{ST-BY} = 0$ to 1.5V			100	$\mu A$
$V_{SB}$	ST-BY In Threshold Voltage				1.5	V
$V_{SB}$	ST-BY Out Threshold Voltage		3.5			V
$I_{pin7}$	ST-BY Pin Current	Play Mode $V_{pin7} = 5V$			50	$\mu A$
		Max Driving Current Under Fault (*)			5	mA
$I_{cd\ off}$	Clipping Detector Output Average Current	$d = 1\%$ (**)		90		$\mu A$
$I_{cd\ on}$	Clipping Detector Output Average Current	$d = 5\%$ (**)		160		$\mu A$
$V_{sat\ pin10}$	Voltage Saturation on pin 10	Sink Current at Pin 10 = 1mA			0.7	V

(\*) See built-in S/C protection description

(\*\*) Pin 10 Pulled-up to 5V with 10K $\Omega$ ;  $R_L = 4\Omega$

(\*\*\*) Saturated square wave output.

STANDARD TEST AND APPLICATION CIRCUIT

Figure 1: Quad Stereo

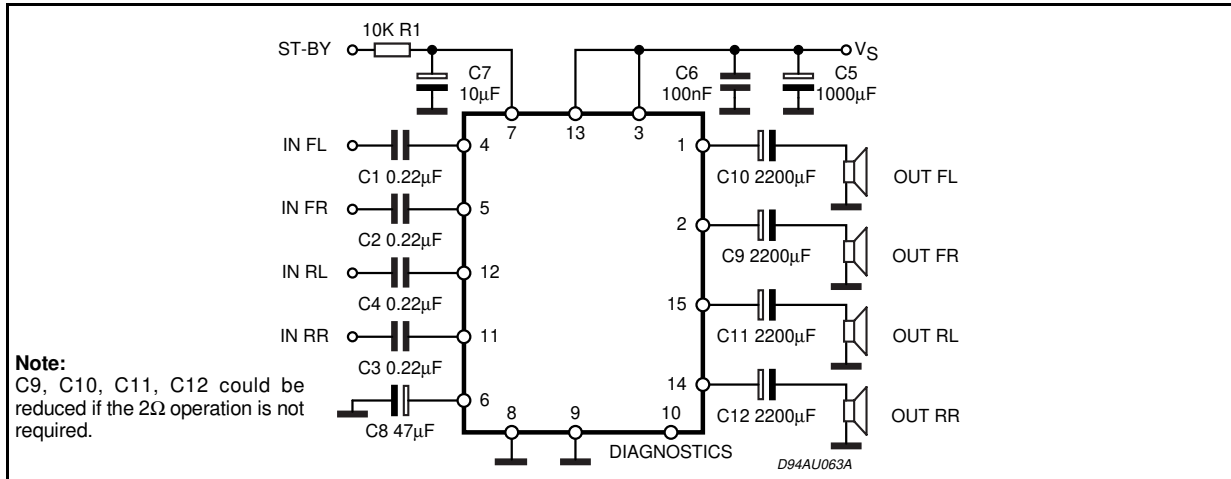

Figure 2: Double Bridge

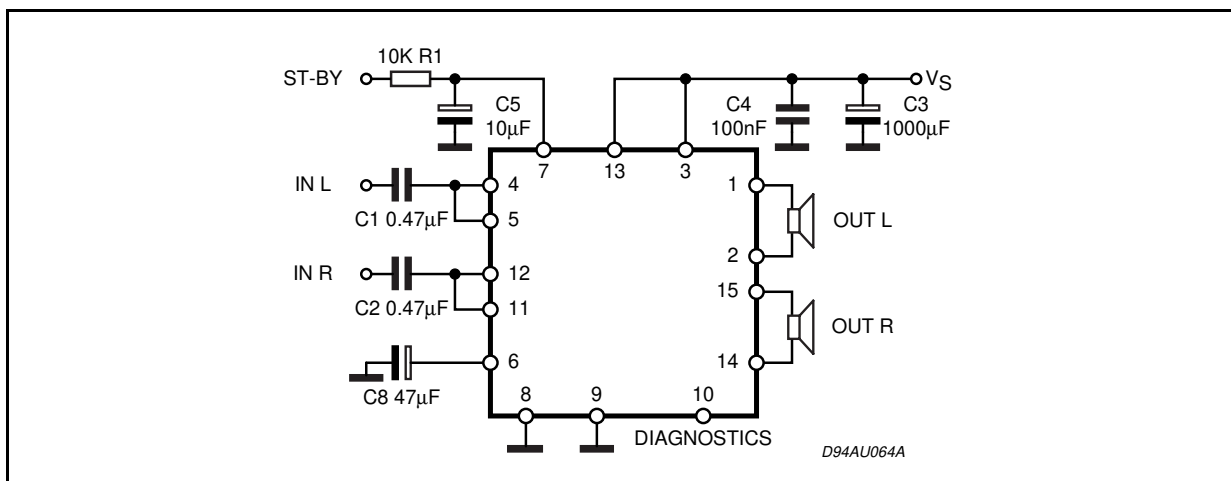

Figure 3: Stereo/Bridge

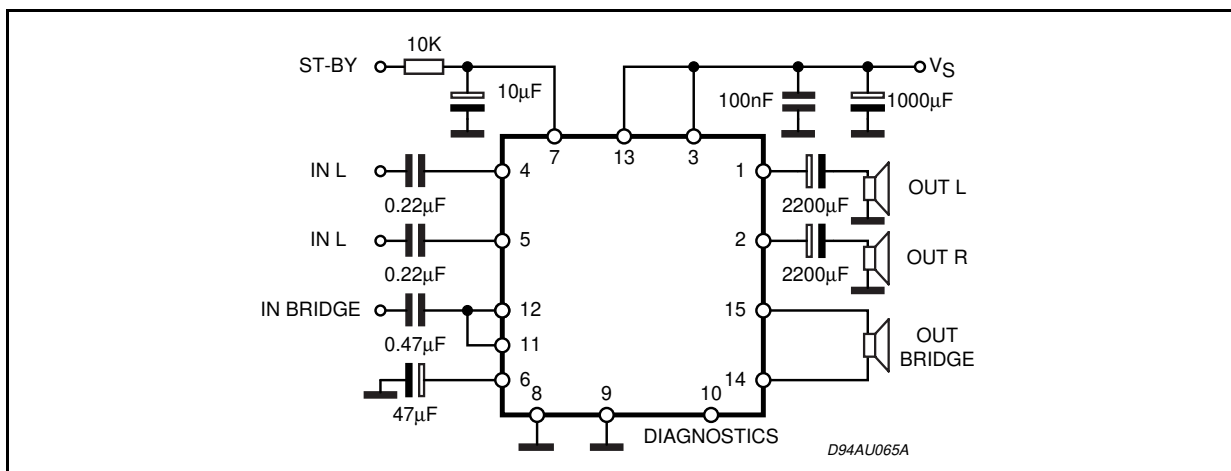

Figure 4: P.C. Board and Component Layout of the fig.1 (1:1 scale).

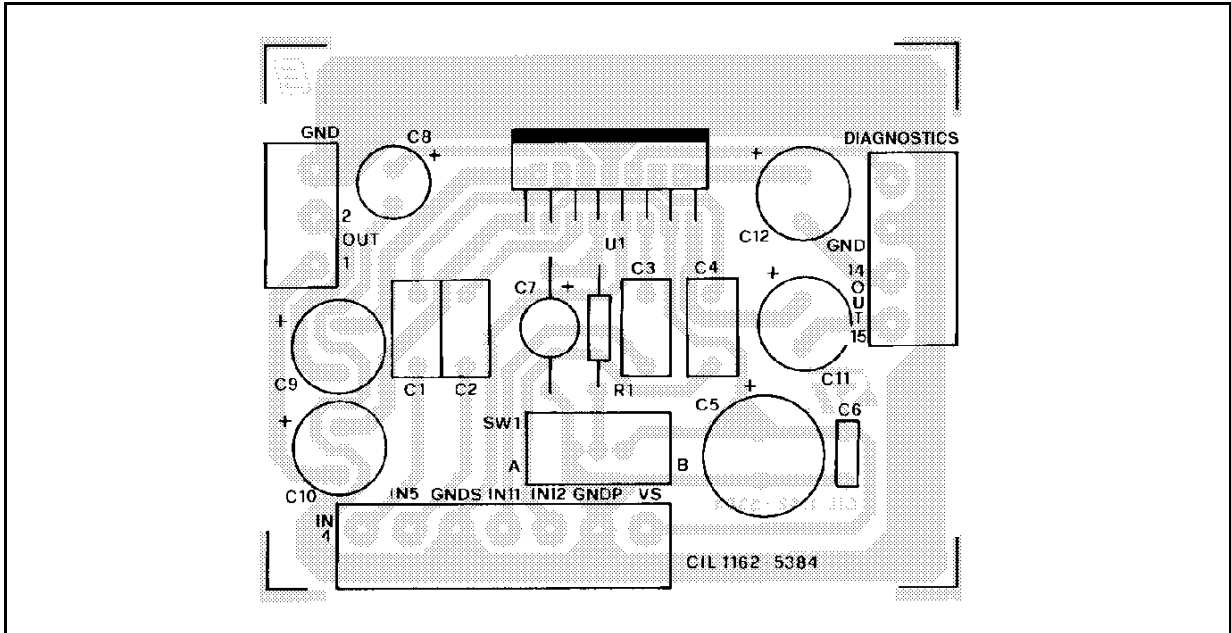
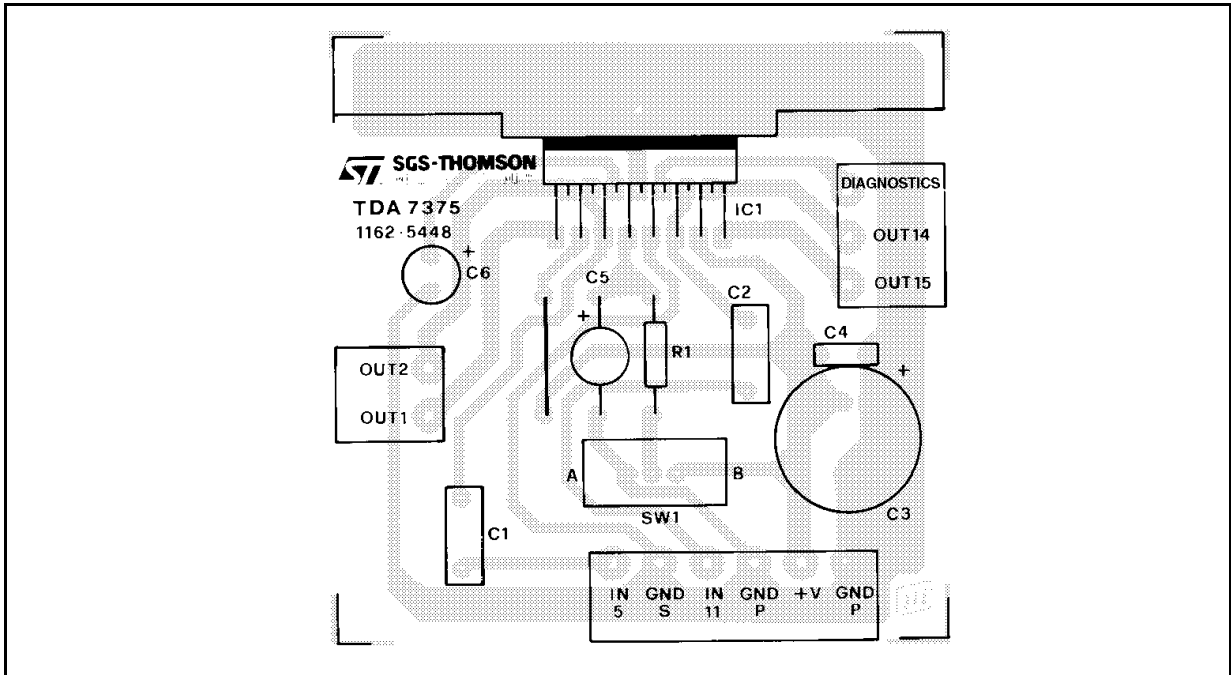
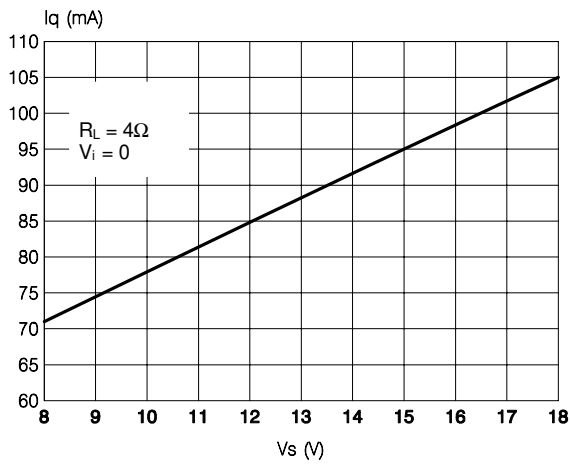

Figure 5: P.C. Board and Component Layout of the fig.2 (1:1 scale).



**Figure 6:** Quiescent Drain Current vs. Supply Voltage (Single Ended and Bridge).



**Figure 7:** Quiescent Output Voltage vs. Supply Voltage (Single Ended and Bridge).

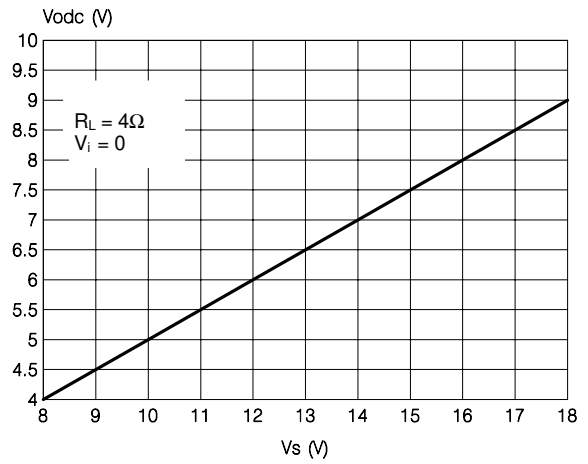

**Figure 8:** Output Power vs. Supply Voltage

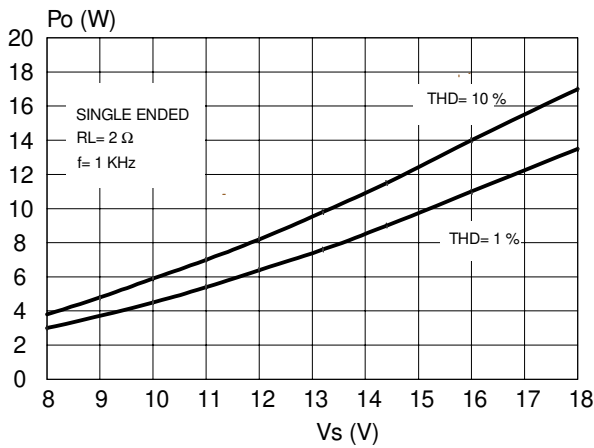

**Figure 9:** Output Power vs. Supply Voltage

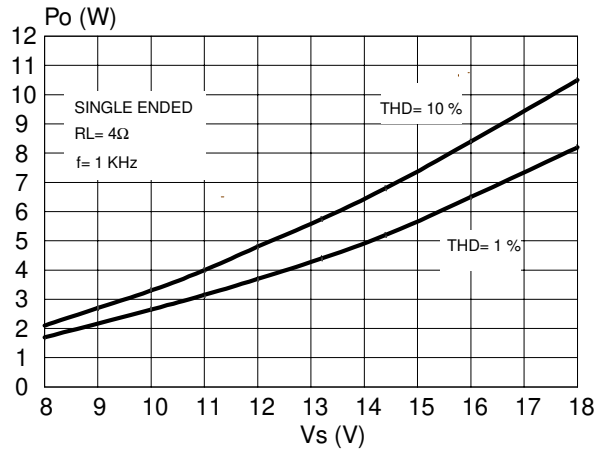

**Figure 10:** Output Power vs. Supply Voltage

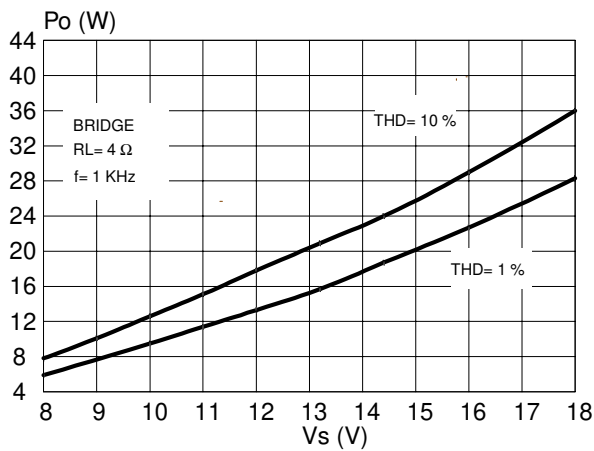

**Figure 11:** Distortion vs. Output Power

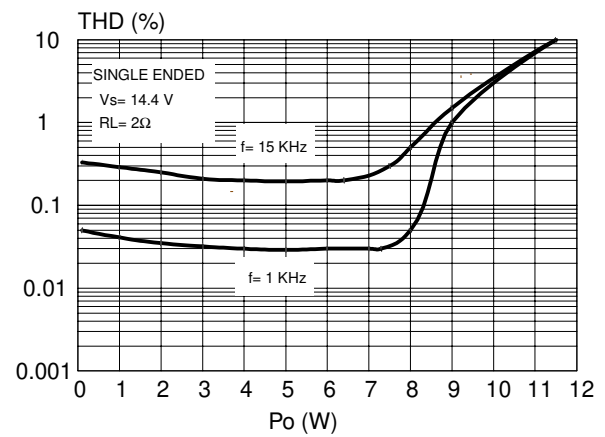

Figure 12: Distortion vs. Output Power

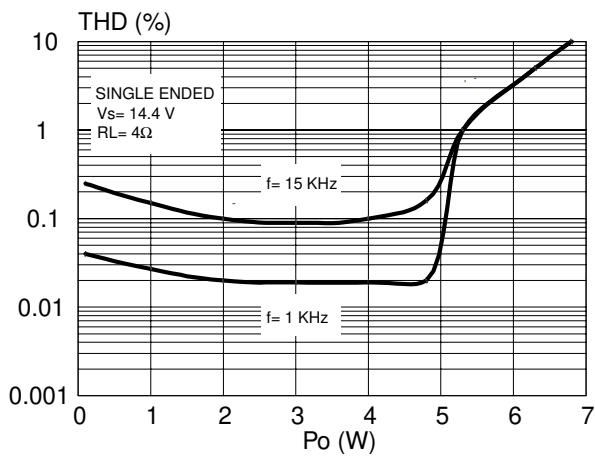

Figure 13: Distortion vs. Output Power

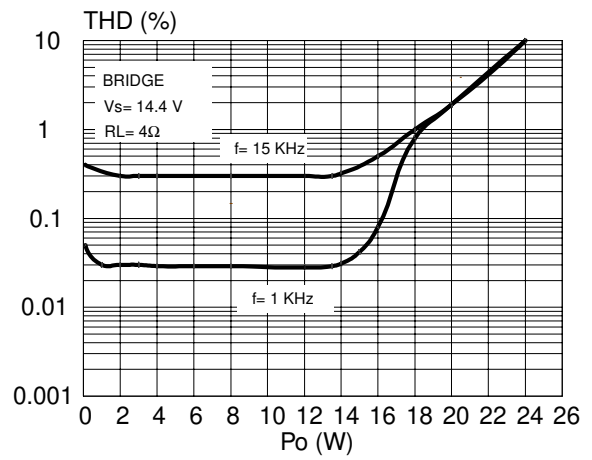

Figure 14: Cross-talk vs. Frequency

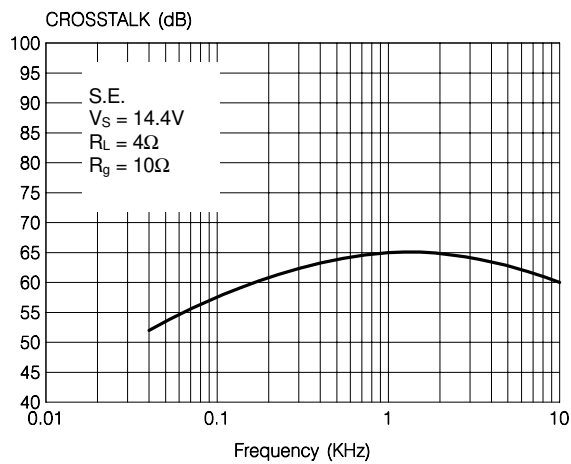

Figure 15: Supply Voltage Rejection vs. Frequency

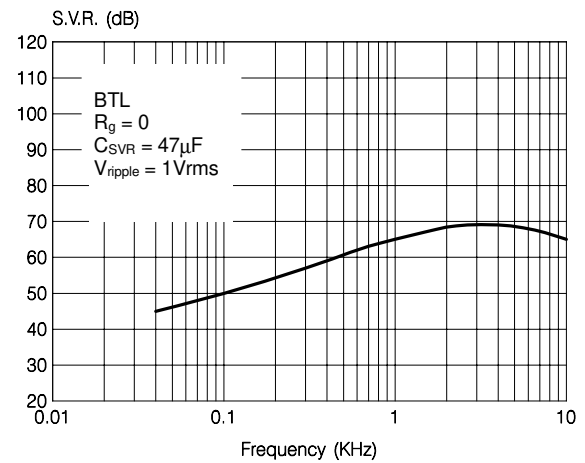

Figure 16: Supply Voltage Rejection vs. Frequency

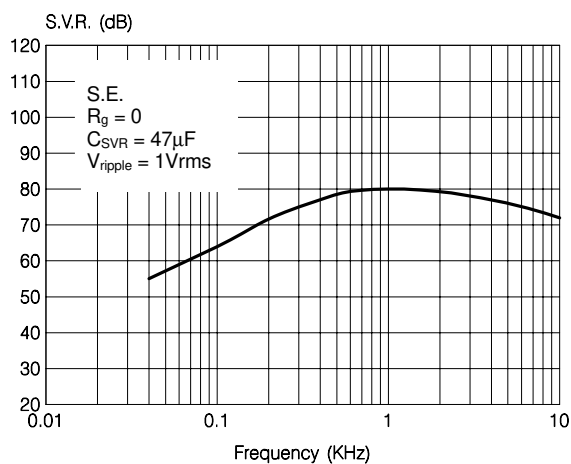
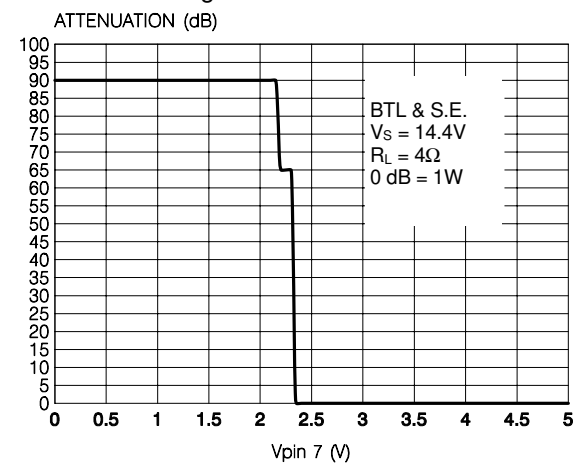
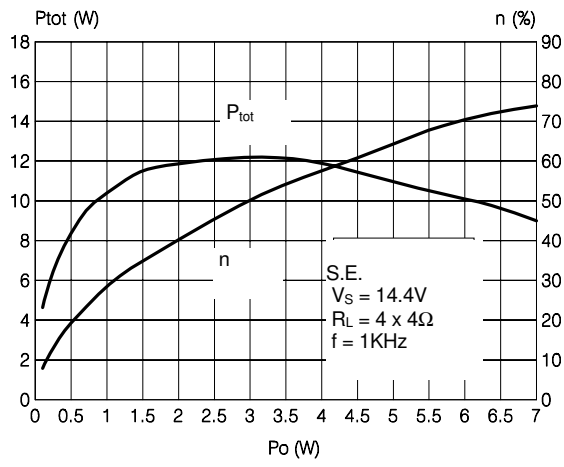

Figure 17: Stand-by Attenuation vs. Threshold Voltage

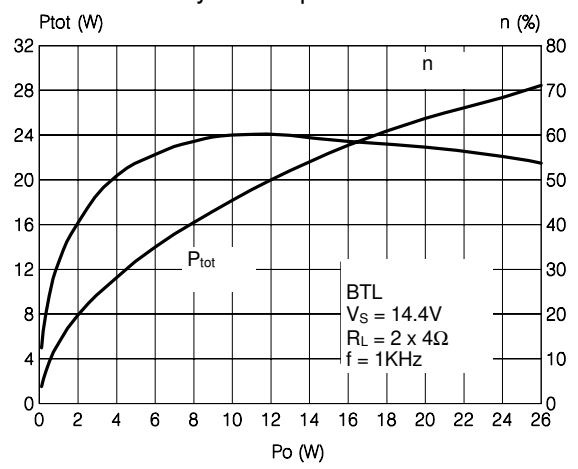



**Figure 18:** Total Power Dissipation and Efficiency vs. Output Power



**Figure 19:** Total Power Dissipation and Efficiency vs. Output Power.



## GENERAL STRUCTURE

### High Application Flexibility

The availability of 4 independent channels makes it possible to accomplish several kinds of applications ranging from 4 speakers stereo (F/R) to 2 speakers bridge solutions.

In case of working in single ended conditions the polarity of the speakers driven by the inverting amplifier must be reversed respect to those driven by non inverting channels.

This is to avoid phase inconveniences causing sound alterations especially during the reproduction of low frequencies.

### Easy Single Ended to Bridge Transition

The change from single ended to bridge configurations is made simply by means of a short circuit across the inputs, that is no need of further external components.

### Gain Internally Fixed to 20dB in Single Ended, 26dB in Bridge

Advantages of this design choice are in terms of:

- components and space saving
- output noise, supply voltage rejection and distortion optimization.

### Silent Turn On/Off and Muting/Stand-by Function

The stand-by can be easily activated by means of a CMOS level applied to pin 7 through a RC filter. Under stand-by condition the device is turned off completely (supply current = 1µA typ.; output attenuation = 80dB min.).

Every ON/OFF operation is virtually pop free. Furthermore, at turn-on the device stays in muting condition for a time determined by the value assigned to the SVR capacitor.

While in muting the device outputs becomes insensitive to any kinds of signal that may be present at the input terminals. In other words every transient coming from previous stages produces no unpleasant acoustic effect to the speakers.

### STAND-BY DRIVING (pin 7)

Some precautions have to be taken in the definition of stand-by driving networks: pin 7 cannot be directly driven by a voltage source whose current capability is higher than 5mA. In practical cases a series resistance has always to be inserted, having it the double purpose of limiting the current at pin 7 and to smooth down the stand-by ON/OFF transitions - in combination with a capacitor - for output pop prevention.

In any case, a capacitor of at least 100nF from pin 7 to S-GND, with no resistance in between, is necessary to ensure correct turn-on.

## OUTPUT STAGE

The fully complementary output stage was made possible by the development of a new component: the ST exclusive power ICV PNP.

A novel design based upon the connection shown in fig. 20 has then allowed the full exploitation of its possibilities.

The clear advantages this new approach has over classical output stages are as follows:

- **Rail-to-Rail Output Voltage Swing With No Need of Bootstrap Capacitors.**

The output swing is limited only by the  $V_{CEsat}$  of the output transistors, which is in the range of  $0.3\Omega$  ( $R_{sat}$ ) each.

Classical solutions adopting composite PNP-NPN for the upper output stage have higher saturation loss on the top side of the waveform. This unbalanced saturation causes a significant power reduction. The only way to recover power consists of the addition of expensive bootstrap capacitors.

- **Absolute Stability Without Any External Compensation.**

Referring to the circuit of fig. 20 the gain  $V_{Out}/V_{In}$  is greater than unity, approximately  $1 + R2/R1$ . The DC output ( $V_{CC}/2$ ) is fixed by an auxiliary amplifier common to all the channels.

By controlling the amount of this local feedback it is possible to force the loop gain ( $A*\beta$ ) to less than unity at frequency for which the phase shift is  $180^\circ$ . This means that the output buffer is intrinsically stable and not prone to oscillation.

Most remarkably, the above feature has been achieved in spite of the very low closed loop gain of the amplifier.

In contrast, with the classical PNP-NPN stage, the solution adopted for reducing the gain at high frequencies makes use of external RC networks, namely the Boucherot cells.

Figure 20: The New Output Stage

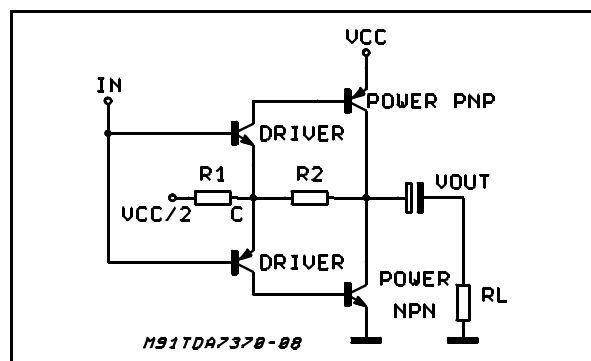

**BUILT-IN SHORT CIRCUIT PROTECTION**

Reliable and safe operation, in presence of all kinds of short circuit involving the outputs is assured by BUILT-IN protectors. Additionally to the AC/DC short circuit to GND, to  $V_s$ , across the speaker, a SOFT SHORT condition is signalled out during the TURN-ON PHASE so assuring correct operation for the device itself and for the loudspeaker.

This particular kind of protection acts in a way to avoid that the device is turned on (by ST-BY) when a resistive path (less than 16 ohms) is present between the output and GND. As the involved circuitry is normally disabled when a current higher than 5mA is flowing into the ST-BY pin, it is important, in order not to disable it, to have the external current source driving the ST-BY pin limited to 5mA.

This extra function becomes particularly attractive when, in the single ended configuration, one capacitor is shared between two outputs (see fig. 21).

**Figure 21.**

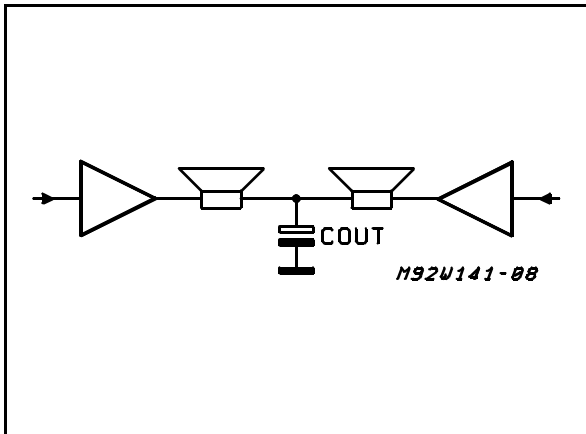

Supposing that the output capacitor  $C_{out}$  for any reason is shorted, the loudspeaker will not be damaged being this soft short circuit condition revealed.

**Diagnostics Facility**

The TDA7377 is equipped with a diagnostic circuitry able to detect the following events:

- Clipping in the output signal
- Thermal shutdown
- Output fault:
  - short to GND
  - short to  $V_s$
  - soft short at turn on

The information is available across an open collector output (pin 10) through a current sinking when the event is detected

**Figure 22: Clipping Detection Waveforms**

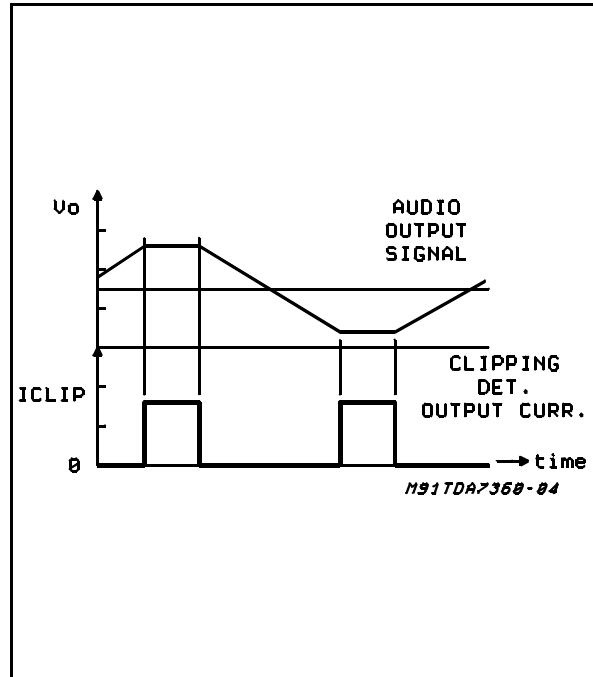

A current sinking at pin 10 is triggered when a certain distortion level is reached at any of the outputs. This function allows gain compression possibility whenever the amplifier is overdriven.

**Thermal Shutdown**

In this case the output 10 will signal the proximity of the junction temperature to the shutdown threshold. Typically current sinking at pin 10 will start  $\sim 10^\circ\text{C}$  before the shutdown threshold is reached.

**Figure 23: Output Fault Waveforms (see fig. 24)**

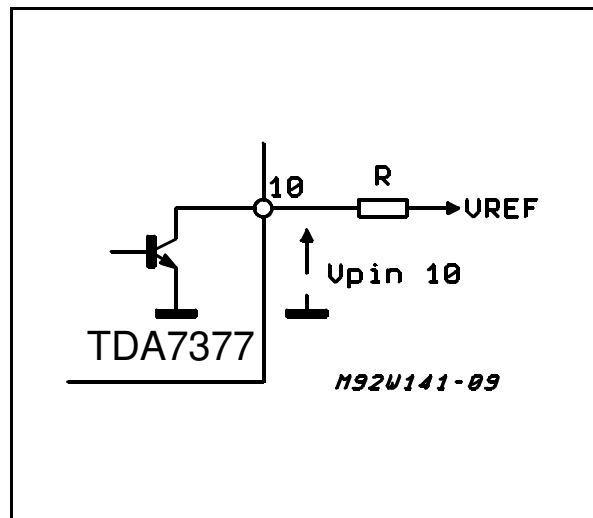
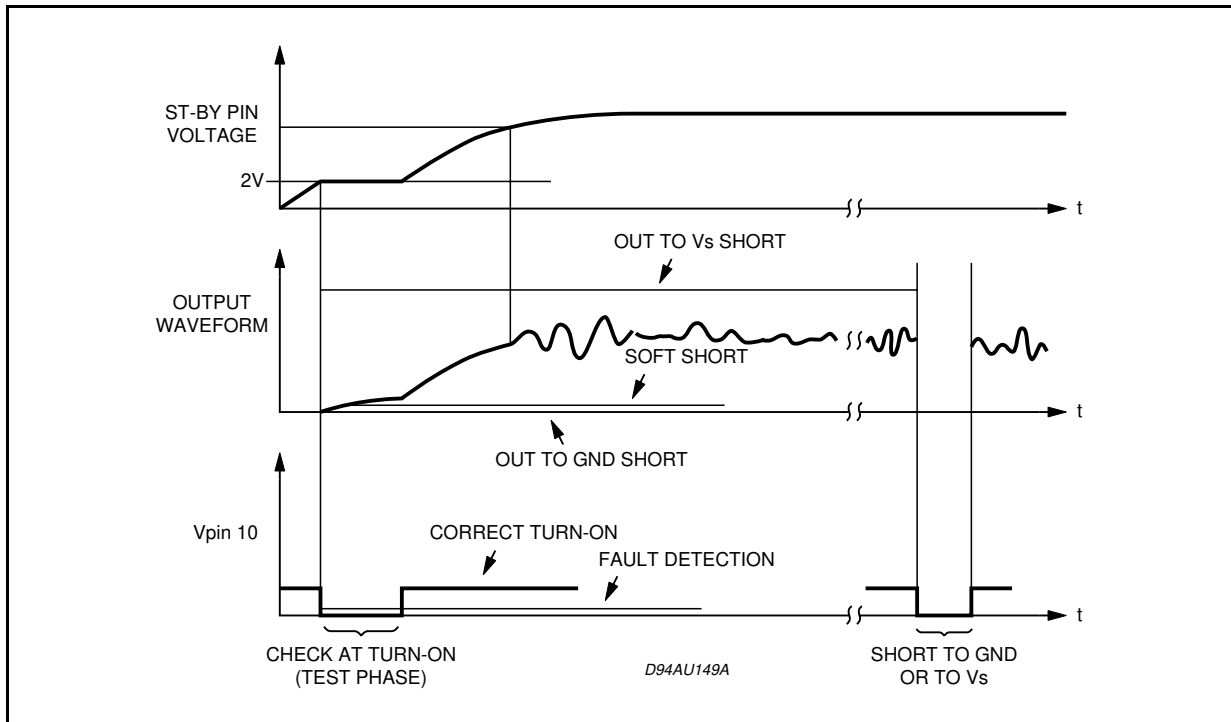

Figure 24: Fault Waveforms



**HANDLING OF THE DIAGNOSTICS INFORMATION**

As various kinds of information is available at the same pin (clipping detection, output fault, thermal

proximity), this signal must be handled properly in order to discriminate each event.

This could be done by taking into account the different timing of the diagnostic output during each case.

Figure 25: Waveforms

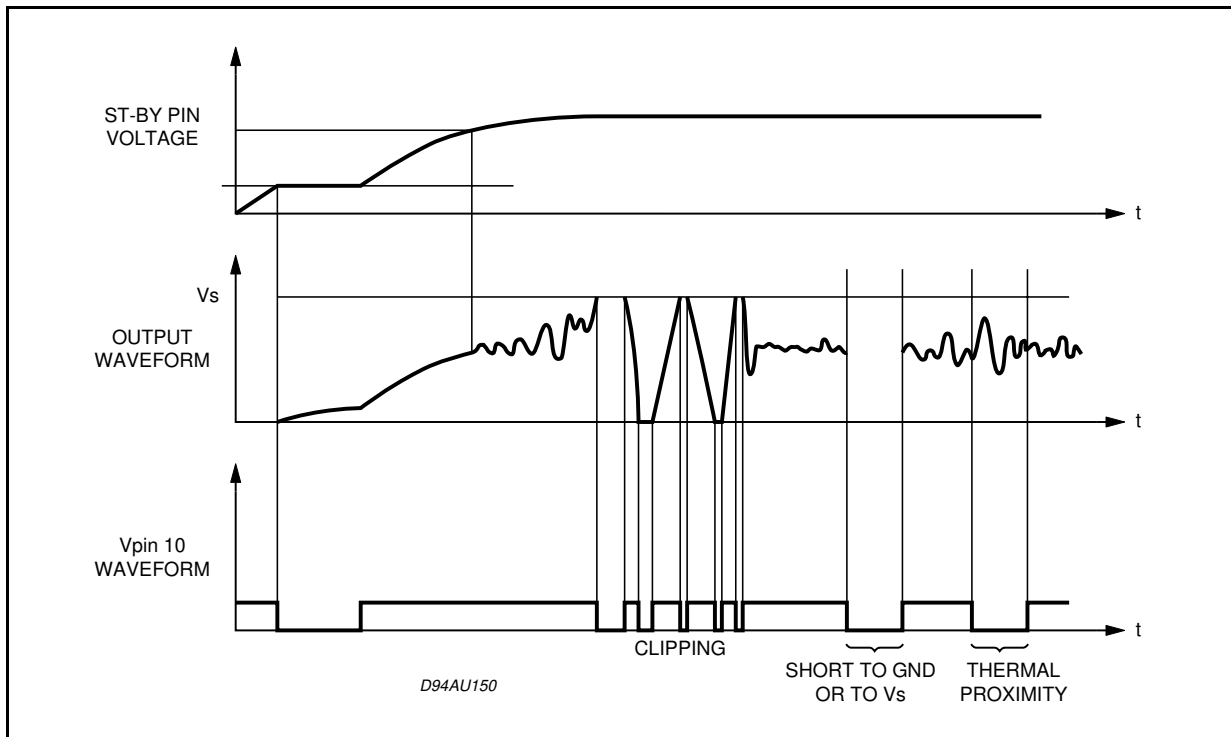

## TDA7377

Normally the clip detector signalling produces a low level at pin 10 that is shorter than that present under faulty conditions; based on this assumption

an interface circuitry to differentiate the information is represented in the schematic of fig. 26.

Figure 26.

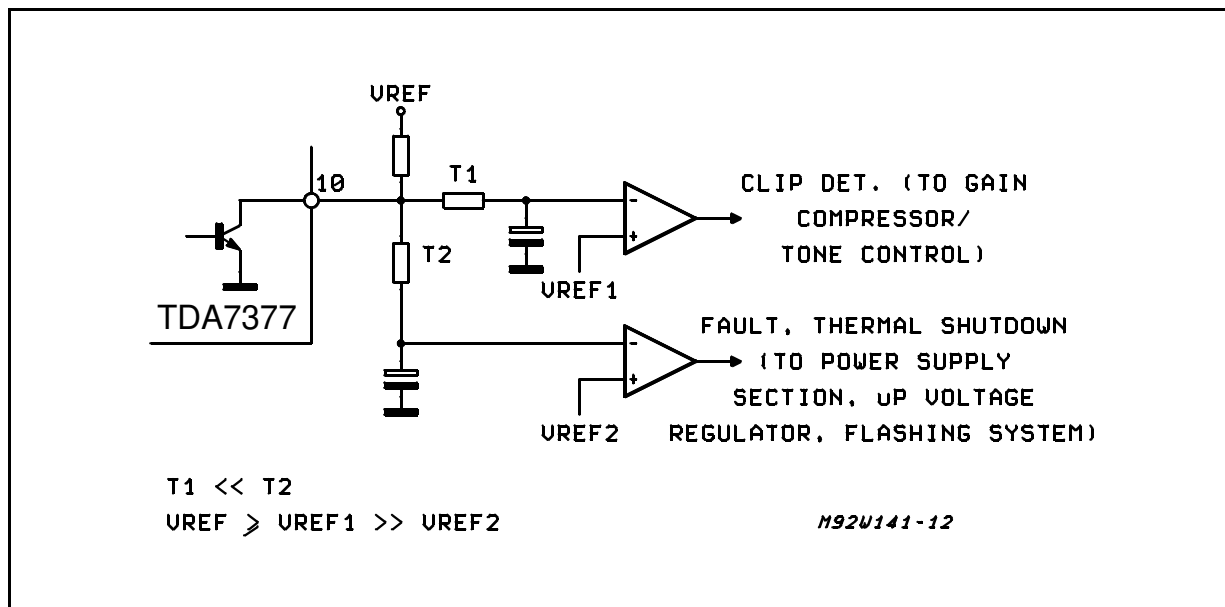

### PCB-LAYOUT GROUNDING (general rules)

The device has 2 distinct ground leads, P-GND (POWER GROUND) and S-GND (SIGNAL GROUND) which are practically disconnected from each other at chip level. Proper operation requires that P-GND and S-GND leads be connected together on the PCB-layout by means of reasonably low-resistance tracks.

As for the PCB-ground configuration, a star-like arrangement whose center is represented by the supply-filtering electrolytic capacitor ground is highly advisable. In such context, at least 2 separate paths have to be provided, one for P-GND and one for S-GND. The correct ground assign-

ments are as follows:

STANDBY CAPACITOR, pin 7 (or any other standby driving networks): on S-GND

SVR CAPACITOR (pin 6): on S-GND and to be placed as close as possible to the device.

INPUT SIGNAL GROUND (from active/passive signal processor stages): on S-GND.

SUPPLY FILTERING CAPACITORS (pins 3,13): on P-GND. The (-) terminal of the electrolytic capacitor has to be directly tied to the battery (-) line and this should represent the starting point for all the ground paths.

## MULTIWATT 15 VERTICAL PACKAGE MECHANICAL DATA

DIM.	mm			inch		
	MIN.	TYP.	MAX.	MIN.	TYP.	MAX.
A			5			0.197
B			2.65			0.104
C			1.6			0.063
D		1			0.039	
E	0.49		0.55	0.019		0.022
F	0.66		0.75	0.026		0.030
G	1.02	1.27	1.52	0.040	0.050	0.060
G1	17.53	17.78	18.03	0.690	0.700	0.710
H1	19.6			0.772		
H2			20.2			0.795
L	21.9	22.2	22.5	0.862	0.874	0.886
L1	21.7	22.1	22.5	0.854	0.870	0.886
L2	17.65		18.1	0.695		0.713
L3	17.25	17.5	17.75	0.679	0.689	0.699
L4	10.3	10.7	10.9	0.406	0.421	0.429
L7	2.65		2.9	0.104		0.114
M	4.25	4.55	4.85	0.167	0.179	0.191
M1	4.63	5.08	5.53	0.182	0.200	0.218
S	1.9		2.6	0.075		0.102
S1	1.9		2.6	0.075		0.102
Dia1	3.65		3.85	0.144		0.152

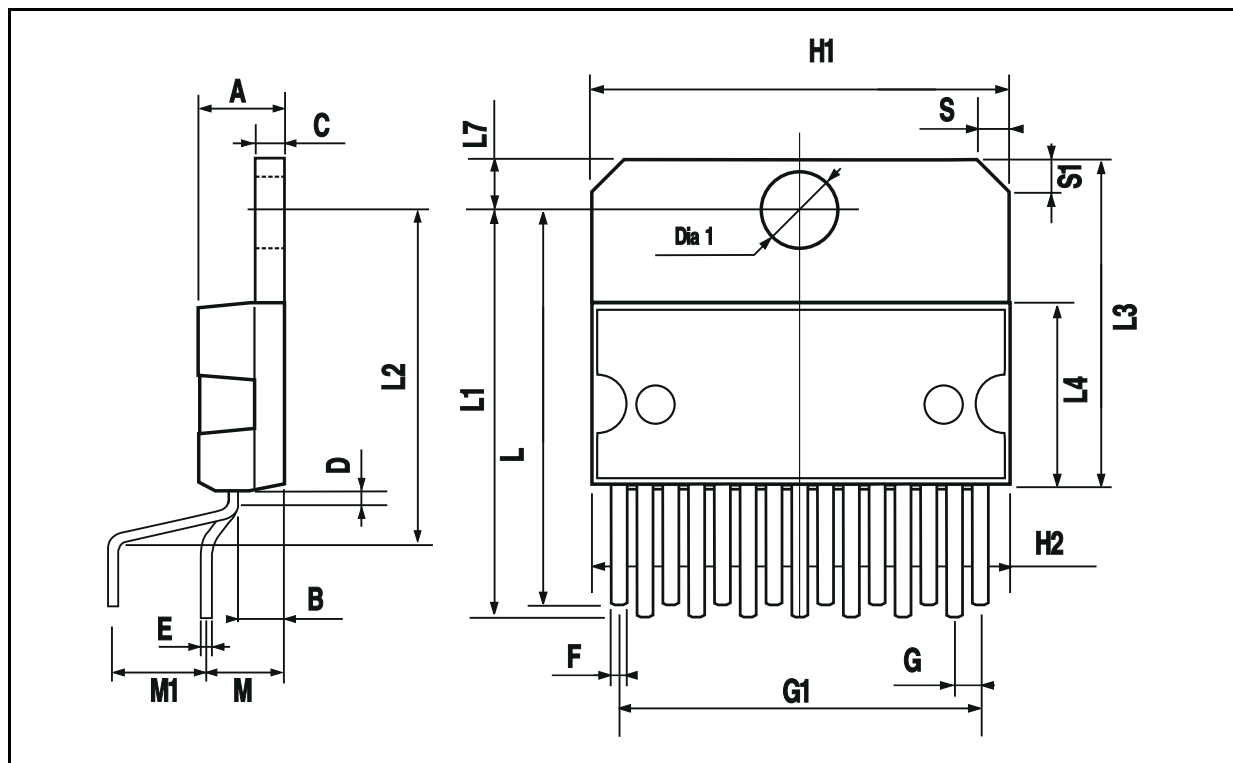

Information furnished is believed to be accurate and reliable. However, STMicroelectronics assumes no responsibility for the consequences of use of such information nor for any infringement of patents or other rights of third parties which may result from its use. No license is granted by implication or otherwise under any patent or patent rights of STMicroelectronics. Specification mentioned in this publication are subject to change without notice. This publication supersedes and replaces all information previously supplied. STMicroelectronics products are not authorized for use as critical components in life support devices or systems without express written approval of STMicroelectronics.

The ST logo is a registered trademark of STMicroelectronics  
© 1999 STMicroelectronics – Printed in Italy – All Rights Reserved

STMicroelectronics GROUP OF COMPANIES

Australia - Brazil - Canada - China - France - Germany - Italy - Japan - Korea - Malaysia - Malta - Mexico - Morocco - The Netherlands -  
Singapore - Spain - Sweden - Switzerland - Taiwan - Thailand - United Kingdom - U.S.A.

<http://www.st.com>