



HESTORE.HU

elektronikai alkatrész áruház

EN: This Datasheet is presented by the manufacturer.

Please visit our website for pricing and availability at www.hestore.hu.

AM2120 Technical Manual

ASAIR[®]

Temperature and Humidity Sensor

- Full calibration
- Digital output, unibus interface
- Excellent long-term stability
- Quick response and strong anti-jamming capability

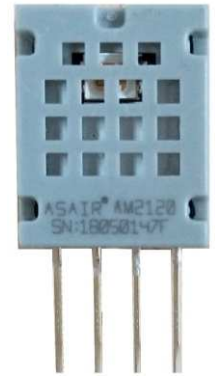

Product overview

AM2120 Digital Temperature and Humidity Module is a temperature and humidity composite sensor with its calibrated digital signal output. It applies special digital module acquisition technology and temperature and humidity sensing technology, to ensure that the product has high reliability and excellent long-term stability. The product has the advantages of excellent quality, ultra-fast response, strong anti-interference ability and high cost performance. Each sensor is calibrated in an extremely accurate humidity calibration laboratory. Calibration coefficients are stored in the form of program in the single chip computer. These calibration coefficients are called in the process of processing the detection signal inside the sensor. Standard single bus interface makes system integration easy and fast. Standard single bus interface makes system integration easy and fast. Ultra-small size, very low power consumption, Signal transmission distance can reach more than 20 meters, making it the best choice for all kinds of applications and even the most demanding applications. Products are cited as 3Wire (single bus interface) connection is convenient. Special encapsulation forms can be provided according to user's needs requirements.

Application scope

HVAC system, dehumidifier, test and inspection equipment, consumer goods, automobiles, automatic control, data recorder, weather station, household appliances, humidity regulation, medical and other related temperature and humidity detection and control.

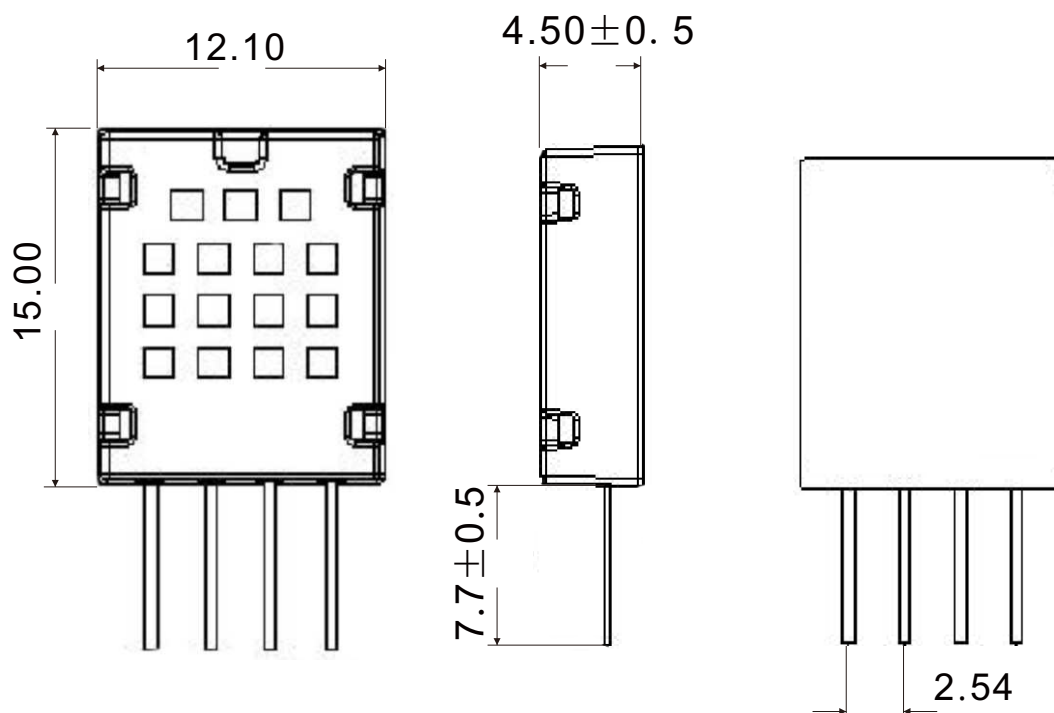

Figure 1: AM2120 Sensor Package Diagram (Unit: mm Unmarked tolerance: 0.1 mm)

Sensor performance

Relative humidity

Parameter	Condition	Min	Typical	Max	Unit
Resolution ratio			0.1		%RH
Measuring range	extended ¹	0		99.9	%RH
Accuracy ²			± 3	See Figure 2	%RH
Repeatability			± 1		%RH
Interchangeability		completely interchangeable			
Response time ³	1/e(63%)		<6		S
Hysteresis			± 0.3		%RH
Drift ⁴			<0.5		%RH/yr

Table 1 Humidity Characteristic

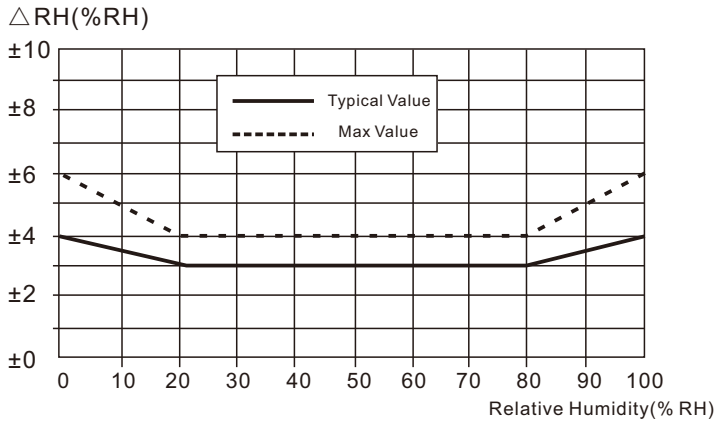

Figure 2 The maximum error of relative humidity at 25°C

Temperature

Parameter	Condition	Min	Typical	Max	Unit
Resolution ratio			0.1		°C
Accuracy			± 0.5	See Figure 3	°C
Measuring range		-40		80	°C
Repeatability			± 0.2		°C
Interchangeability		completely interchangeable			
Response time ³	1/e(63%)		<10		S
Drift			± 0.3		°C/yr

Table 3 Temperature Characteristic

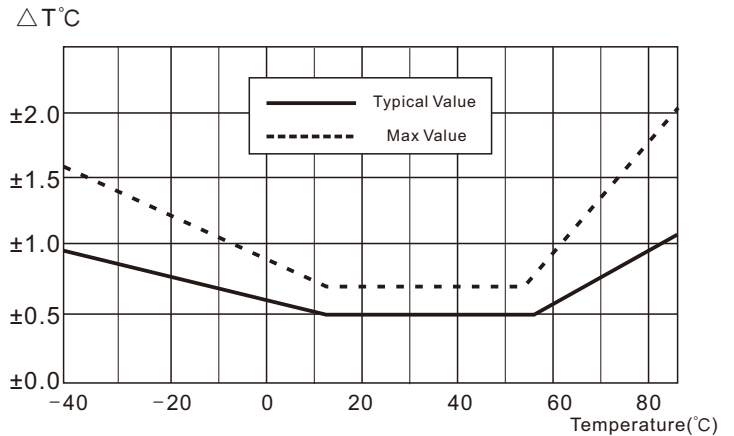

Figure 3 Typical error and maximum error of temperature

Electric specification

Parameter	Condition	Min	Typical	Max	Unit
Supply Voltage		3.3	5	5.5	V
Power consumption ⁵	Sleep	2	15		μA
	measuring		1200		μA
	Average		600		μA
Low level output voltage	I _{ol} ⁶	0		300	mV
High level output voltage	R _p <25 kΩ	90%		100%	VDD
Low level input voltage	Decline	0		30%	VDD
High level input voltage	Rise	70%		100%	VDD
R _{pu} ⁷	VDD = 5V VIN = VSS	1	5.1	100	kΩ
Output current	Open		8		mA
	Tri-state (turn off)	10	20		μA
Sampling period		2			S

Table 2. Electric Specification

- 1 Normal working scope: 0 - 80% RH. Sensor reading will be deviated if beyond this range, (drift < 3% RH after 200 hours at 90% RH humidity). The working scope is further limited to - 40~80°C.
- 2 This precision is the test precision of the sensor with 5V voltage at 25°C excluding hysteresis and nonlinearity, and only suitable for non-condensation conditions.
- 3 The time required to reach 63% of the first-order response under the conditions of 25°C and 1 m/s air flow.
- 4 If the sensor is surrounded by volatile solvents, irritating tapes, adhesives and packaging materials, the reading may be higher. For more information, please refer to the relevant documents.
- 5 The minimum and maximum of power consumption are based on the conditions of VDD = 5 V and T < 60 °C. The average value is value measured every two seconds.
- 6 Low level output current
- 7 Represents pull up resistance.
- 8 The response time depends on the thermal conductivity of the sensor substrate.

AM2120 User Guide

1 Expansion of performance

1.1 Working conditions

The sensor performance is stable in the suggested working scope, as shown in Figure 4. Long-term exposure to abnormal scope, especially when humidity > 80%, may lead to temporary signal drift (drift + 3% RH after 60 hours). When the sensor is restored to normal working conditions, it will slowly restore itself to the correct state. Refer to Recovery Processing in Section 2.2 to speed up the recovery process. Long-term use under abnormal conditions will accelerate the aging of products.

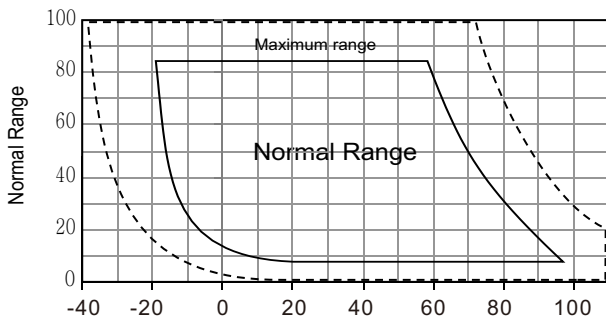

Figure 4 Working Conditions Temperature (°C)

1.2 RH accuracy at different temperatures

The RH accuracy at 25°C is defined in Figure. 2, and the typical humidity error at other temperatures is shown in Fig. 5.

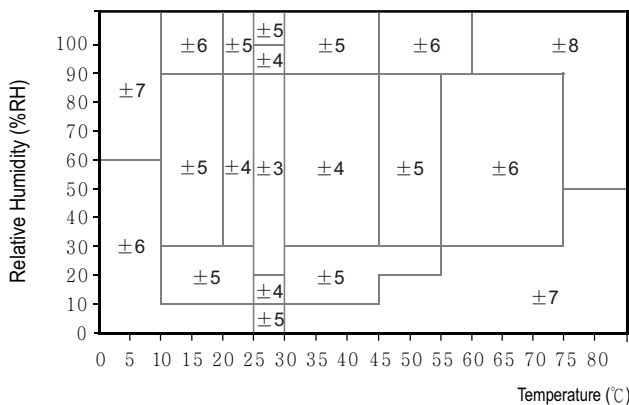

Figure 5 Typical humidity error between 0-80 °C, unit: (% RH)

Note: Above errors are the tested typical errors (excluding hysteresis) with the high precision dew-point instrument as reference instrument.

2 Application information

2.1 Storage conditions and instructions

The humidity sensitivity level (MSL) is 1, according to IPC/JEDEC J-STD-020 standard. Therefore, it is recommended to use it within one year after delivery.

Humidity sensor is not an ordinary electronic component, and it needs careful protection, which users must pay attention to. Long-term exposure to high concentration of chemical vapor will cause the sensor reading to drift. Therefore, it is recommended that the sensor be stored in the original package including sealed ESD bag, and meet the following conditions: temperature range 10°C - 50°C (0 - 85°C in a limited time), humidity 20 - 60% RH (no ESD packaged sensor). For sensors that have been removed from the original package, we recommend that they be stored in antistatic bags made of metal PET / AL / CPE.

During production and transportation, sensors should avoid exposure to high concentration of chemical solvents and prolonged exposure. Avoid exposure to volatile glue, adhesive tape, stickers or volatile packaging materials, such as foamed foil, foam material, etc. The production area should be well ventilated.

2.2 Recovery processing

As mentioned above, if the sensor is exposed to extreme working conditions or chemical vapor, the reading will drift. It can be restored to the calibration state by processing as follows.

Drying: Keep for 10 hours at 80 - 85°C and less than 5% RH humidity.

Rehydration: Keep for 12 hours⁹ at 20 - 30°C with the humidity of more than 75 % RH.

2.3 Temperature influence

The relative humidity of gases depends largely on temperature. Therefore, when measuring humidity, all sensors measuring the same humidity should work at the same temperature as possible. When testing, it is necessary to ensure that the tested sensors and reference sensors are at the same temperature, and then compare the humidity readings.

Moreover, when the measurement frequency is too high, the temperature of the sensor itself will rise, which will affect the measurement accuracy. In order to make its temperature rise below 0.1°C, the activation time of AM2120 should not exceed 10% of the measurement time - it is recommended to measure data every 2 seconds.

⁹ 75%RH can be easily generated from saturated NaCl.

2.4 Material used for sealing and encapsulation

Many materials absorb moisture and act as buffer, which will increase response time and hysteresis. Therefore, the material around the sensor should be carefully selected. Recommended materials are: metal materials, LCP, POM (Delrin), PTFE (Teflon), PE, PEEK, PP, PB, PPS, PSU, PVDF, and PVF. Material for sealing and bonding (conservative recommendation): It is recommended to use method of filling epoxy resin or silicone resin for packaging electronic components. Gases released from these materials may also contaminate AM2120 (see 2.1). Therefore, the sensor should be finally assembled and placed in a well-ventilated place, or dried for 24 hours in an environment of > 50°C, in order to release the contaminated gas before packaging.

3 Interface definition

Pin	Color	Name	Description
1	Red	VDD	Power (3.3V-5.5V)
2	Yellow	SDA	Serial data,two-way port
3	Black	GND	Ground
4		NC	No Connection

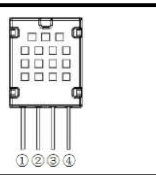

Table 4 Interface definition description

3.1 Power pin(VDD GND)

The power supply range of AM2120 is 3.3-5.5V,5.0V is suggested.

3.2 Serial data(SDA)

The SDA pin is a three-state structure for reading and writing sensor data.For the specific communication sequence, see the detailed description of the communication protocol.

4 Electric specification

4.1 Absolute maximum rating

The electric specifications of AM2120 are defined in Table 2. The absolute maximum ratings given in Table 5 are only stress ratings and to provide more information. Under such conditions, it is not advisable for the device to perform functional operation. Exposure to absolute maximum rating for a long time may affect the reliability of the sensor.

Parameters	Min	Max	Unit
VDD to GND	-0.3	5.5	V
Digital I/O pin (SDA, SCL) to GND	-0.3	VDD + 0.3	V
Input current for each pin	-10	10	mA

Table 5 Absolute maximum electric rating

ESD electrostatic discharge conforms to JEDEC JESD22-A114 standard (human body mode ±4kV) and JEDEC JESD22-A115 (machine mode±200V). If the test condition exceeds the nominal limit, the sensor needs additional protection circuit.

4.2 Input/output characteristics

Electric specifications include power consumption, high and low voltage of input and output, voltage of power supply. In order to make the sensor communication smooth, it is important to ensure that the signal design is strictly limited to the range given in Tables 2 and Figure 9.

5 One-wire bus communication

5.1 One-wire bus typical circuit

The typical application circuit connecting the microprocessor and AM2120 is shown in figure 6.In one-wire bus communication mode, the SDA pull-up is connected to the microprocessor's I/O port.

Special specification for one-wire bus communication:

- 1.In a typical application circuit, it is recommended to use 5.1k pull-up resistance when the length of the connection wire is shorter than 30m, and lower the resistance value of the pull-up resistance according to the actual situation when it is larger than 30m.
- 2.When using 3.3V voltage supply, the length of connection wire shall not be greater than 1m. Otherwise, the line pressure drop will cause insufficient sensor power supply, resulting in measurement errors.
- 3.Read the sensor minimum every 2 seconds. If the reading interval is less than 2 seconds, may lead to temperature or humidity is not allowed or communication is not successful.When the sensor is powered on at the beginning, it should wait for more than 2s before reading the sensor to avoid the unstable state of the sensor.
- 4.The temperature and humidity value read out each time is the result of the last measurement. In order to obtain real-time data, it is necessary to read the sensor twice continuously. It is recommended to read the sensor several times continuously, and the accurate data can be obtained when the sensor interval is more than 2 seconds.

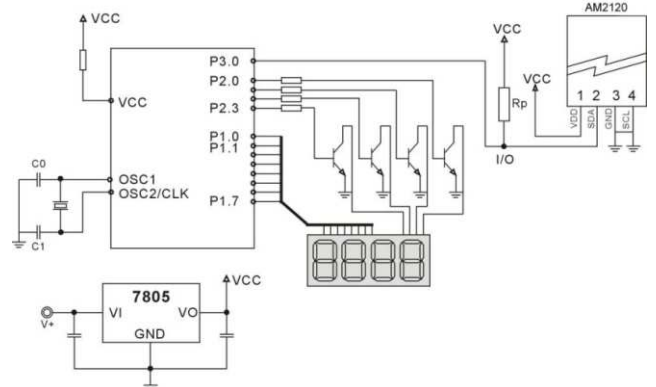

Figure 6 AM2120 One-wire bus application circuitry

5.2 One-wire bus communication protocol

◎ One-wire bus descriptions

The AM2120 uses simplified one-wire bus communication, the one-wire bus has only one data line, and the data exchange and control in the system are completed by the data line. The micro-controller is connected to the data line via a drain open circuit or a three state port, allows the device to release the bus without sending data, let other devices use the bus. A single bus usually requires an external pull up resistor of about 4.7k, thus, when the bus is idle, the state is high. Because they are the principal and subordinate structure, only the host call sensor, the sensor can response, so the host access sensor must strictly follow the single bus sequence, if the sequence of chaos, sensor will not respond to host.

◎ One-wire bus transmits data definitions

SDA is used for communication and synchronization between micro controller and AM2120, and uses single bus data format to transmit 40 bit data at one time. The specific communication sequence is shown in Figure 7, and the communication format specification is shown in Table 6.

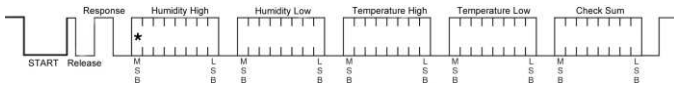

Figure7 One-wire bus communication protocol of AM2120

Name	Single bus format definition
START	The microprocessor pulls the data bus (SDA) down for a period of time (at least 1ms), informing the sensor to prepare the data.
Response	The sensor pulls the data bus (SDA) low by 80µs and pills up by 80µs in response to the host's start signal.
Data format	Once receipted from the host start signal, the sensor collects 40 bits of data from the data bus (SDA) at one time, High first out.
Humidity	Humidity resolution is 16Bit, high bit in the former; sensor string out the humidity value is 10 times the actual humidity value.
Temperature	Temperature resolution is 16Bit, high in the former; sensor string out of the temperature value is 10 times the actual temperature; The highest temperature (Bit15) is equal to 1 for negative temperature, the highest temperature bit (Bit15) is equal to 0 for positive temperature; Temperature in addition to the most significant bit (Bit14 ~ Bit0) that the temperature value.
Check Sum	Check Sum Humidity high bit+Humidity low bit+Temperature high bit+Temperature low bit

Table 6 AM2120 communication format specification

◎ Examples for one-wire bus data calculation

Example 1:Received 40 bit data is:

00000010 10010010 00000001 00001101 10100010
Humidity high Humidity low Temperature high Temperature high Check sum

Calculation:

$00000010+10010010+00000001+00001101=10100010$ (Check sum)

Received data is correct:

Humidity: $00000010\ 10010010=0292H$ (Hexadecimal)= $2 \times 256 + 9 \times 16 + 2 = 658$
=> Humidity = 65.8%RH

Temperature: $00000001\ 00001101=10DH$ (Hexadecimal)= $1 \times 256 + 0 \times 16 + 13 = 269$
=> Temperature= 26.9°C

◎ Special instructions:

When the temperature is below 0 ° C, the highest bit of the temperature data is 1

Example 1 : -10.1 °C => 1 000 0000 0110 0101

Temperature: $0000\ 0000\ 0110\ 0101 = 0065H$ (Hexadecimal)= $6 \times 16 + 5 = 101$
=> Temperature = -10.1°C

Example 2 :received 40 bit data is:

00000010 10010010 00000001 00001101 10110010
Humidity high Humidity low Temperature high Temperature high Check sum

Calculation:

$00000010+10010010+00000001+00001101=10100010 \neq 10110010$

(Check error)

The data received this time is not correct. Give up and re-receive data.

5.3 One-wire bus communication timing

The AM2120 switches from Sleep to High Speed mode when the user host (MCU) sends a start signal (pulls the data bus SDA low by at least 800µs). After the host start signal is completed, the AM2120 sends a response signal and sends 40Bit from the data bus SDA serially. The high bit of the data is sent first. The data sent is: the high bits of humidity, the low bits of humidity, the high bits of temperature, the low bits of temperature, the check digit. The information is collected after sending data ends and the sensor is automatically transferred to the sleep mode until the next A communication comes.

Detailed timing signal characteristics shown in Table 7, single bus communication timing diagram shown in Figure 8.

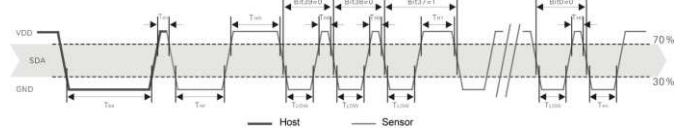

Figure 8 AM2120 Single bus communication timing

Note: The temperature and humidity data the host read from the AM2120 is always the previous measurement. If the two measurement interval is very long, please read twice and use the second measurement value as the value of real-time temperature and humidity values. While reading ,make sure the minimum interval between two measurement is 2 Second.

Table 7 One-wire bus signal characteristics

Symbol	Parameter	min	type	max	Units
T _{be}	Time of the host start signal is pulled low	0.8	1	20	mS
T _{go}	Time of the host releases the bus	10	30	200	μS
T _{rel}	Time to response low level	75	80	85	μS
T _{reh}	Time to response high level	75	80	85	μS
T _{LOW}	Signal "0" low level time	48	50	55	μS
T _{H0}	Signal "0" high level time	22	26	30	μS
T _{H1}	Signal "1" high level time	68	70	75	μS
T _{en}	Time of the sensor releases the bus	45	50	55	μS

Note: To ensure accurate communication of the sensor, please strictly in accordance with parameters and timing design of Table 7 and Figure 8 when reading the sensors.

5.4 Peripheral read step example

Communication between the host and the sensor can complete by the following three steps.

Step 1:

After the AM2120 is powered on (the AM2120 will wait 2S to go beyond the unstable state, during which time the device can not send any instructions), test the environment temperature and humidity data, and record the data, then the sensor automatically goes to sleep. AM2120 SDA data line pulled up by the pull-up resistor and then would keep high, at this state, AM2120 is detect the external signal continuously, and its SDA pin in the input state.

Step 2:

The I/O of the microprocessor is set to output and the output is low, and the low hold time can not be less than 1ms. Then the microprocessor's I / O is set to the input state, the bus is released. When the host release bus, AM2120 send a response signal, mean 80ms low output as a response signal. After that an 80ms high output to inform the peripherals ready to receive data, the signal transmission shown in Figure 9:

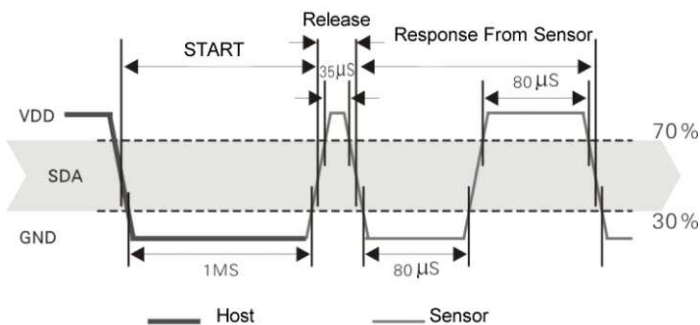

Figure 9 Single Bus Decomposition Timing Diagram

Step 3:

After AM2120 sends the response, then the data bus SDA continuously outputs 40 bits of data, and the microprocessor receives 40 bits of data according to the change of I/O level.

The format of the bit data "0" is: 50 ms low level plus 26-28 ms high level;

The format of the bit data "1" is: 50 ms low level plus 70 ms high level;

The format of the bit data "0", bit data "1" are shown in Figure 10.

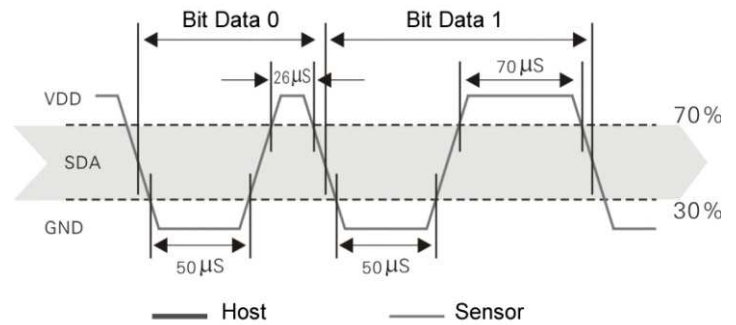

Figure 10 One-wire bus decomposition sequence diagram

After the data bus SDA of AM2120 outputs 40-bit data, it continues to output the low level for 50 microseconds and then turns to the input state. Due to the pull-up resistance, it then changes to the high level. At the same time, the internal temperature and humidity data of AM2120 were retested, and the data were recorded. After the test record was completed, the microcontroller automatically entered the sleep state. MCU only received the host after the start of the signal, to re-wake the sensor, into the working state.

5.5 Peripheral read flow chart

The flow chart diagram of AM2120 sensor read one-wire bus is shown in figure 11. At the same time, our company also provides an example of reading code. For customers who need to download, please log on our company's website (www.aosong.com) for relevant downloading.

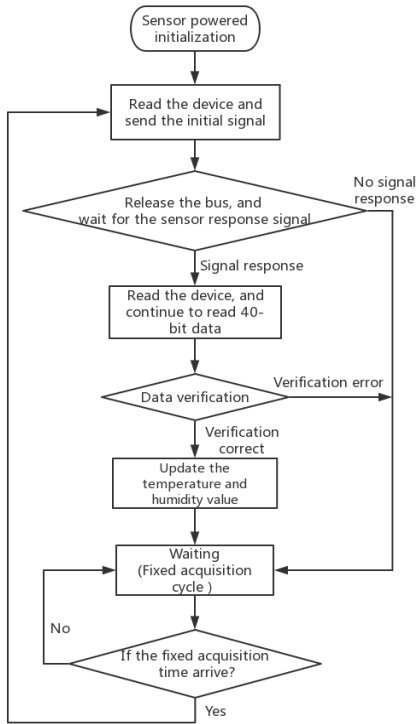

Figure 11 The one-wire bus read flow chart

Antistatic bags are also labeled, as shown in figure 13, and provides additional tracking information.

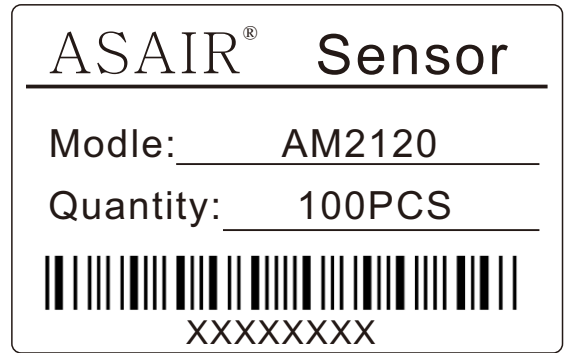

Figure13 Label on anti-static bag

7.2 Transport Package

AM2120 is palletized with 50 sensors in each blister box. Each two blister boxes are sealed in an anti-static shielding bag with a total of 100 sensors. The packaging diagram with sensor positioning is shown in figure 14. The blister box is placed in an anti-static shielding bag.

6 Environmental stability

If the sensor is used in equipment or machinery, please make sure that it is the same temperature and humidity that the sensor used for measurement and the sensor used for reference that have sensed. If the sensor is placed in the equipment, the reaction time will be prolonged, so it is necessary to ensure that sufficient measurement time is reserved in the programming. The AM2120 sensor is tested according to the enterprise standard of Aosong temperature and humidity sensor. The performance of sensors under other test conditions is not guaranteed and cannot be regarded as a part of sensor performance. Especially for the specific occasions required by users, we do not make any commitments.

7 Package

7.1 Tracking information

All AM2120 sensors have laser identification on the surface as shown in figure 12.

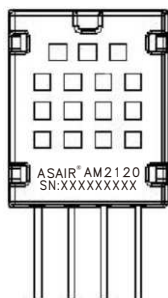

Figure 12 sensor laser identification

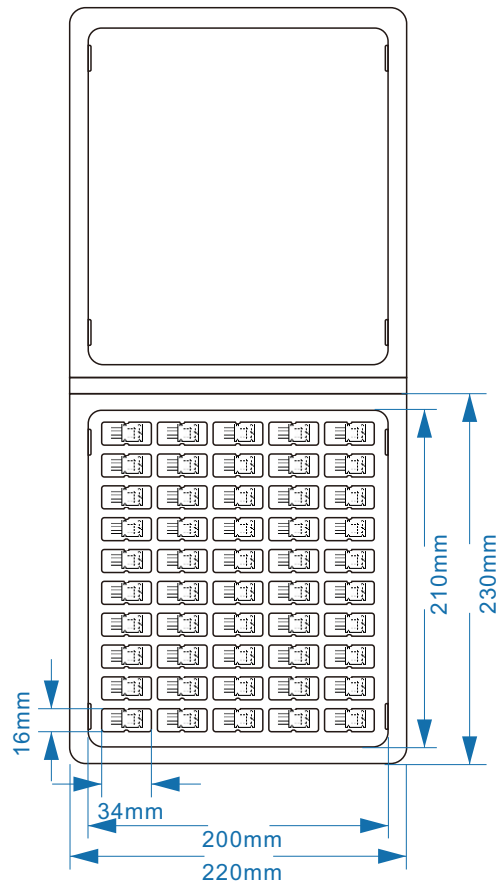

Figure14 Blister box and sensor location diagram

Version

Date	Version	Page	Alteration
2019/03	V1.0	1-8	Initial Version

This manual is likely to change sometime without prior notice.

Attention

Warning of personal injury

Do not apply this product to safety protection devices or emergency stop equipment, as well as any other applications that may cause personal injury due to the failure of the product. This product cannot be used unless there is a special purpose or with an authorization to use it. Please refer to the product data sheet and Application guide before installing, processing, using or maintaining the product. Failure to comply with this recommendation may result in death and serious bodily injury.

If the Buyer intends to purchase or use the Aosong products without any application license and authorization, the buyer shall bear all compensation for personal injury and death resulting therefrom, and shall not claim for compensation including various costs, compensation fees, lawyers, etc. Expenses and so on with the managers and employees of Aosong Company, as well as subsidiaries, agents, distributors, etc.

ESD protection

Due to the inherent component design, it is sensitive to static electricity. In order to prevent the damage and the reduction of the product's performance caused by static electricity, the necessary anti-static measures should be taken when applying this product.

Quality assurance

Our company provides 12-month (1-year) quality assurance for buyers of its products (calculated from the date of delivery) based on the technical specifications in the data manual of the product published by Aosong. If the product is found to be defective under warranty, our company will provide free maintenance or replacement. Users need to satisfy the following conditions:

- Notify our company in writing within 14 days after the defect is found
- The defect of this product will help to find out the deficiency in design, material and technology of our product.
- The product should be sent back to our company at the buyer's expense.
- The product should be under warranty.

Our company is only responsible for the defective products which are used in the occasions that meet the technical requirements of the product. Our company makes no warranties or written representations regarding the use of its products in special application occasions.

At the same time, the company does not make any commitment to the reliability of the products applied to products or circuits.

Copyright©2019 , ASAIR® .