



HESTORE.HU

elektronikai alkatrész áruház

EN: This Datasheet is presented by the manufacturer.

Please visit our website for pricing and availability at www.hestore.hu.

FEATURES

- Demultiplexing capability
- Multiple input enable for easy expansion
- Ideal for memory chip select decoding
- Active LOW mutually exclusive outputs
- Output capability: standard
- Icc category: MSI

GENERAL DESCRIPTION

The 74HC138 are high-speed Si-gate CMOS devices and are pin compatible with low power Scotty TTL (LSTTL). They are specified in compliance with JEDEC standard no. 7A.

The 74HC138 decoders accept three binary

weighted address inputs (A₀, A₁, A₂) and when enabled, provide 8 mutually exclusive active LOW outputs (Y₀ to Y₇).

The "138" features three enable inputs: two active LOW (E₁ and E₂) and one active HIGH (E₃). Every output will be HIGH unless E₁ and E₂ are LOW and E₃ is HIGH.

This multiple enable function allows easy parallel expansion of the "138" to a 1-of-32 (5 lines to 32 lines) decoder with just four "138" ICs and one inverter.

The "138" can be used as an eight output demultiplexer by using one of the active LOW enable inputs as the data input and the remaining enable inputs as strobes. Unused enable inputs must be permanently tied to their appropriate active HIGH or LOW state.

The "138" is identical to the "238" but has inverting outputs.

QUICK REFERENCE DATA

GND = 0 V; T_{amb} = 25 °C; t_r = t_f = 6 ns

SYMBOL	PARAMETER	CPMCONDITIONS	TYPICAL		UNIT
			HC	HCT	
t _{PHL} / t _{PLH} t _{PHL} / t _{PLH}	Propagation delay A _n to Y _n E ₃ to Y _n E _n to Y _n	CL=15pF; Vcc=5V	12 14	17 19	ns ns
CI	Input capacitance		3.5	3.5	pF
C _{PD}	Power dissipation capacitance per package	Notes 1 and 2	67	67	pF

Notes

1. C_{PD} is used to determine the dynamic power dissipation (P_D in μW):

$$P_D = C_{PD} \times V_{CC2} \times f_i + \sum (C_L \times V_{CC2} \times f_o) \text{ where:}$$

f_i = input frequency in MHz

f_o = output frequency in MHz

∑ (C_L × V_{CC2} × f_o) = sum of outputs

C_L = output load capacitance in pF

V_{CC} = supply voltage in V

2. For HC the condition is V_I = GND to V_{CC}

For HCT the condition is V_I = GND to V_{CC} – 1.5 V

ORDERING INFORMATION

See

PIN DESCRIPTION

PIN NO	SYMBOL	NAME AND FUNCTION
1, 2, 3	A0 to A2	Address inputs
4, 5	E1, E2	Enable inputs (active LOW)
6	E3	Enable input (active HIGH)
8	GND	Ground (0V)
15, 14, 13, 12, 11, 10, 9, 7	Y ₀ to Y ₇	Outputs (active LOW)
16	V _{cc}	Positive supply voltage

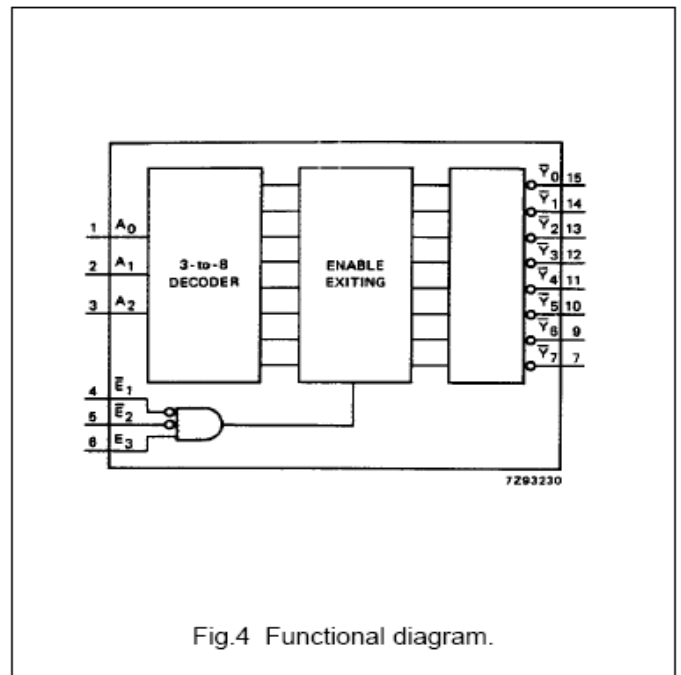
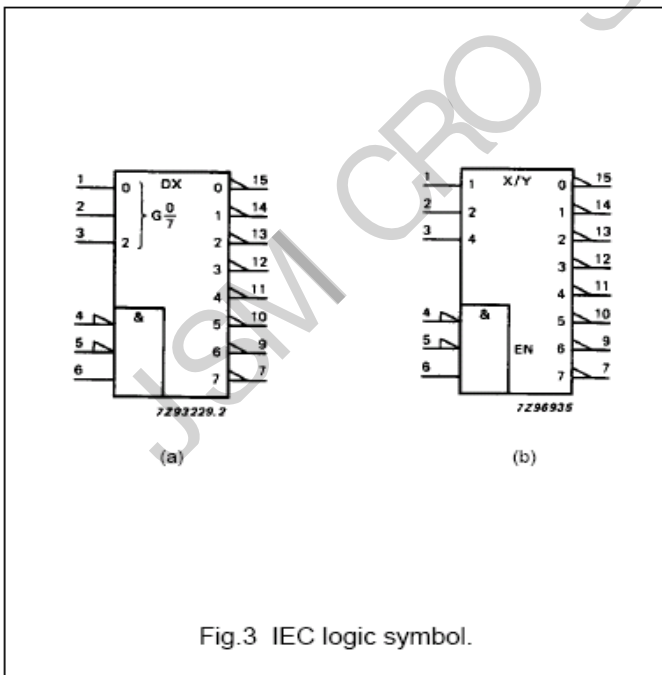
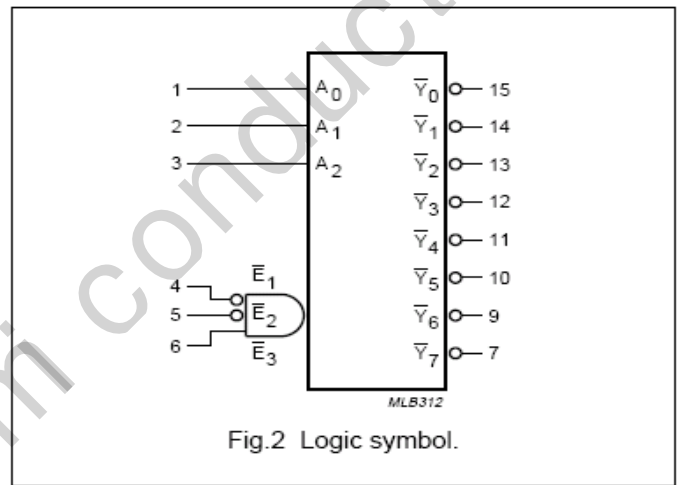
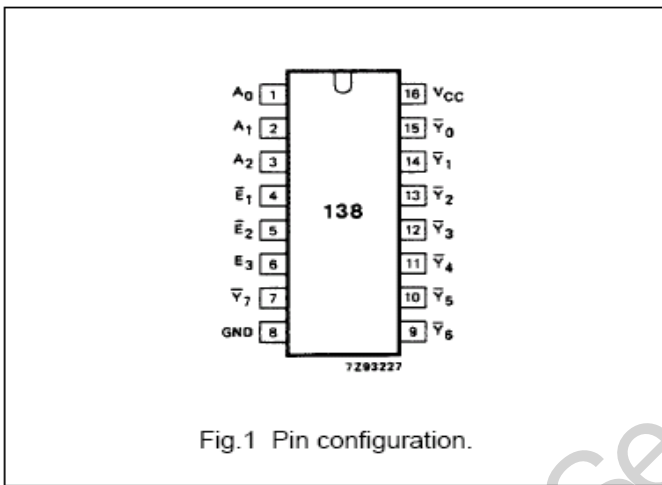

FUNCTION TABLE

INPUTS						OUTPUTS							
E1	E2	E3	A0	A1	A2	Y0	Y1	Y2	Y3	Y4	Y5	Y6	Y7
H	X	X	X	X	X	H	H	H	H	H	H	H	H
X	H	X	X	X	X	H	H	H	H	H	H	H	H
X	X	L	X	X	X	H	H	H	H	H	H	H	H
L	L	H	L	L	L	L	H	H	H	H	H	H	H
L	L	H	H	L	L	H	L	H	H	H	H	H	H
L	L	H	L	H	L	H	H	L	H	H	H	H	H
L	L	H	H	H	L	H	H	H	L	H	H	H	H
L	L	H	L	L	H	H	H	H	H	L	H	H	H
L	L	H	H	L	H	H	H	H	H	H	L	H	H
L	L	H	L	H	H	H	H	H	H	H	H	L	H
L	L	H	H	H	H	H	H	H	H	H	H	H	L

Notes

- H = HIGH voltage level
 L = LOW voltage level
 X = don't care

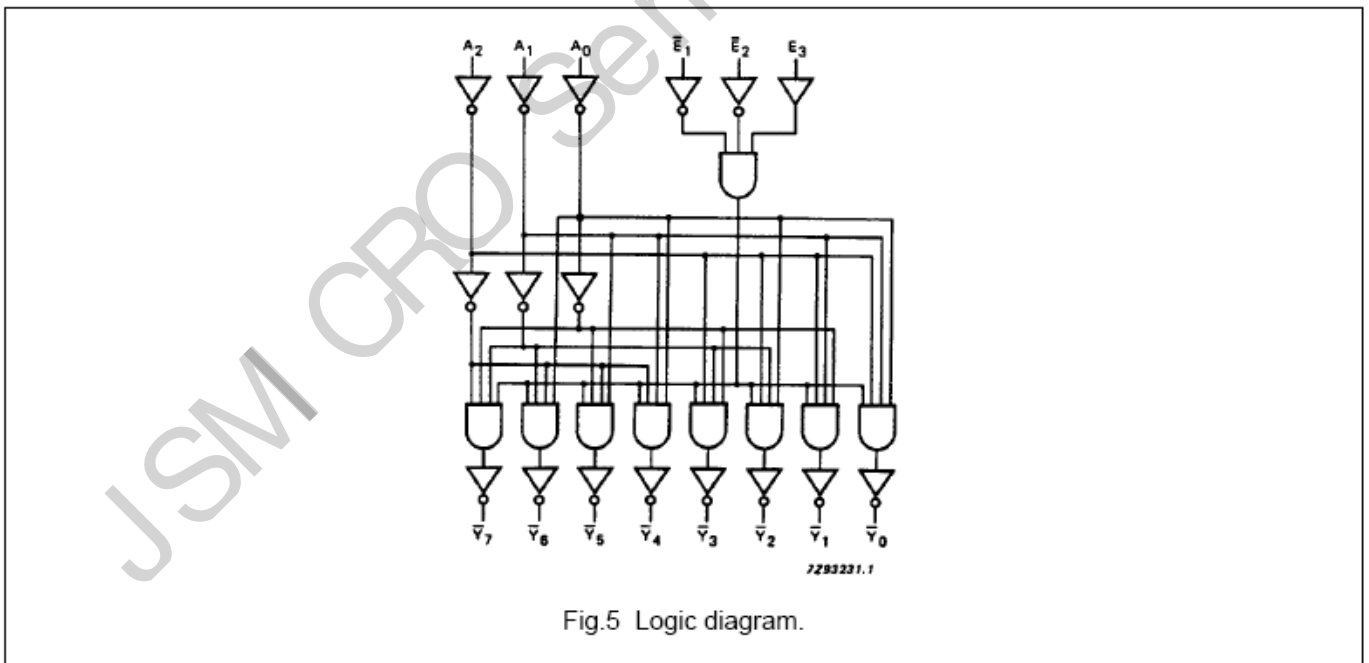

DC CHARACTERISTICS FOR 74HC

For the DC characteristics see

Output capability: standard

Icc category: MSI

AC CHARACTERISTICS FOR 74HC

GND = 0 V; $t_r = t_f = 6$ ns; $C_L = 50$ Pf

SYMBOL	PARAMETER	Tamb(°C)						UNIT	TEST CONDITIONS		
		74HC							Vcc (v)	WAVEFORMS	
		+25			-40 to +85		-40 to +125				
		min	typ	max	min	max	min				max
tPHL/ tPLH	Propagation delay An to Yn		41	150		190		225	ns	2.0 4.5 6.0	Fig. 6
			15	30		38		45			
			12	26		33		38			
tPHL/ tPLH	Propagation delay E3 to Yn		47	150		190		225	ns	2.0 4.5 6.0	Fig. 6
			17	30		38		45			
			14	26		33		38			
tPHL/ tPLH	Propagation delay En to Yn		47	150		190		225	ns	2.0 4.5 6.0	Fig. 7
			17	30		38		45			
			14	26		33		38			
tTHL/ tTLH	Output transition time		19	75		95		110	ns	2.0 4.5 6.0	Fig. 6 and 7
			7	15		19		22			
			6	13		16		19			

DC CHARACTERISTICS FOR 74HCT

For the DC characteristics see

Output capability: standard

Icc category: MSI

Note to HCT types

The value of additional quiescent supply current (ΔI_{cc}) for a unit load of 1 is given in the family specifications. To determine ΔI_{cc} per input, multiply this value by the unit load coefficient shown in the table below.

INPUT	UNIT LOAD COEFFICIENT
An	1.50
En	1.25
E3	1.00

AC CHARACTERISTICS FOR 74HCT

 GND = 0 V; $t_r = t_f = 6$ ns; $C_L = 50$ pF

SYMBOL	PARAMETER	Tamb(°C)								UNIT	TEST CONDITIONS	
		74HCT									Vcc (v)	WAVEFORMS
		+25			-40 to +85		-40 to +125					
		min	typ	max	min	max	min	max				
tPHL/ tPLH	Propagation delay An to Yn		20	35		44		53	ns	4.5	Fig. 6	
tPHL/ tPLH	Propagation delay E3 to Yn		18	40		50		60	ns	4.5	Fig. 6	
tPHL/ tPLH	Propagation delay En to Yn		19	40		50		60	ns	4.5	Fig. 7	
tTHL/ tTLH	Output transition time		7	15		19		22	ns	4.5	Fig. 6 and 7	

AC WAVEFORMS
