



**HESTORE.HU**

elektronikai alkatrész áruház

**EN:** This Datasheet is presented by the manufacturer.

Please visit our website for pricing and availability at [www.hestore.hu](http://www.hestore.hu).

WIRE SIZE	MAX INSULATION	"A" ±.012 ±0.30	"C" ±.012 ±0.30	"D" ±.005 ±0.13	"E" ±.012 ±0.30	"G" ±.005 ±0.13	"H" ±.012 ±0.30
20-24	.073/1.85	.090/2.29	.100/2.54	.030/0.76 R.	.075/1.91	.025/0.64 R.	.082/2.08
26-30	.050/1.27	.075/1.91	.083/2.10	.025/0.64 R.	.058/1.47	.020/0.51 R.	.065/1.65
18 OR 0.75mm <sup>2</sup>	.073/1.85	.091/2.31	.099/2.51	.030/0.76 R.	.086/2.18	.029/0.74 R.	.094/2.39

MATERIAL NUMBER	PLATING	WIRE SIZE	FORM
43030-0001	A	20-24	CHAIN
43030-0002	B	20-24	CHAIN
43030-0003	C	20-24	CHAIN
43030-0004	A	26-30	CHAIN
43030-0005	B	26-30	CHAIN
43030-0006	C	26-30	CHAIN
43030-0007	A	20-24	LOOSE
43030-0008	B	20-24	LOOSE
43030-0009	C	20-24	LOOSE
43030-0010	A	26-30	LOOSE
43030-0011	B	26-30	LOOSE
43030-0012	C	26-30	LOOSE
43030-0038	A	18 OR 0.75mm <sup>2</sup> (SEE NOTE 10)	CHAIN

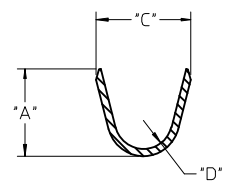
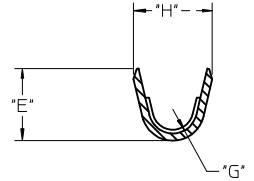

SECTION V-V

SECTION W-W

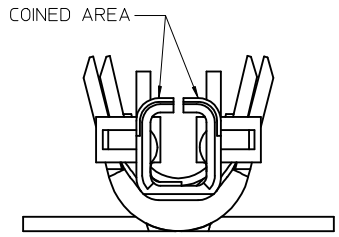
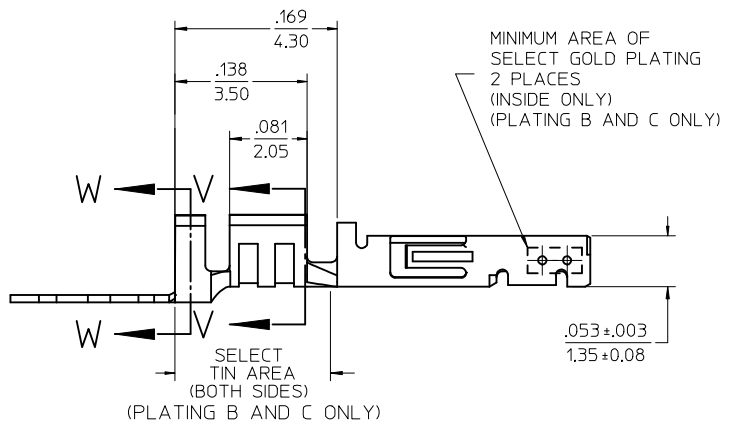
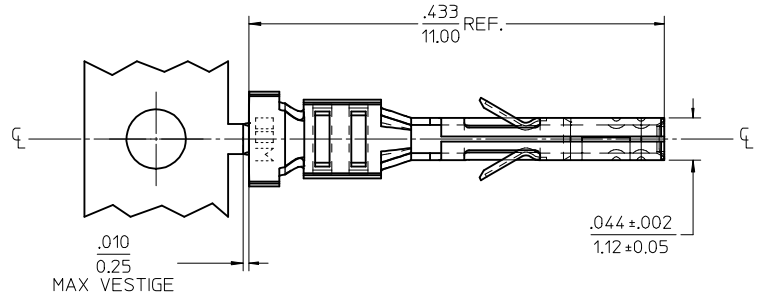

(SCALE 20:1)

NOTES

- MATERIAL: PHOSPHOR BRONZE ALLOY
- TERMINAL PLATING:
  - "A" - HOT TIN DIP: .000040/0.00102 MIN. OVERALL
  - "B" - .000015/0.00038 MIN. SELECT GOLD .000100/0.00254 MIN. SELECT TIN ALL OVER .000050/0.00127 MIN. NICKEL OVERALL.
  - "C" - .000030/0.00076 MIN. SELECT GOLD .000100/0.00254 MIN. SELECT TIN ALL OVER .000050/0.00127 MIN. NICKEL OVERALL.
- PRODUCT SPECIFICATION: PS-43045, PS-43650, PS-44300-001.
- PACKAGING SPECIFICATION: PK-43030-001 (REEL), PK-43030-003 (LOOSE).
- TERMINAL FOR USE IN A MICRO FIT RECEPTACLE #43025-\*\*\*\*, 43645-\*\*\*\*, AND 44133-\*\*\*\*.
- FOR TERMINAL ORIENTATION IN RECEPTACLE SEE DRAWING #SDA-43025 OR SDA-43645.
- THIS TERMINAL IS DESIGNED IN METRIC.
- MOLEX RECOMMENDS THE USE OF MICRO-FIT TEST PLUG (SERIES 44242) WHENEVER CONTINUITY TESTING IS PERFORMED. TEST PLUGS MUST NOT BE USED TO MAKE OR BREAK UNDER LOAD. MOLEX DOES NOT RECOMMEND USING STANDARD MATING COMPONENTS (SERIES 43020, 43045, 43640, 43650, OR 43031) FOR HARNESS TESTING PURPOSES.
- TEXT ON PART IS FOR REFERENCE ONLY. TEXT AND TEXT LOCATION MAY VARY DEPENDING ON PART NUMBER AND/OR TOOL.
- PART NUMBER 43030-0038 IS DESIGNED FOR 18 AWG 1061 STYLE WIRE OR A .073/1.85 MAXIMUM INSULATION OUTSIDE DIAMETER.

UPDATE FACTORY ID EC NO: UCP2017-2563 DRW:ZSHARPER 2017/05/30 CHKD: APPR:FSMLTH 2017/09/29	QUALITY SYMBOLS	GENERAL TOLERANCES (UNLESS SPECIFIED)	DIMENSION STYLE IN/MM	SCALE 10:1	DESIGN UNITS METRIC	THIRD ANGLE PROJECTION
	▽=0	4 PLACES ± --- ± ---	DRAWN BY MUELLER	DATE 2002/08/03	MICRO-FIT (3.0) FEMALE CRIMP TERMINAL  <b>molex</b> DOCUMENT NO. SD-43030-**** SHEET NO. 1 OF 1	
	▽=0	3 PLACES ± --- ±.010	CHECKED BY MUELLER	DATE 2002/08/03		
	▽=0	2 PLACES ±.025 ±.014	APPROVED BY MARGULIS	DATE 2002/08/03		
▽=0	1 PLACE ±.035 ± ---	MATERIAL NO.				
REV N6	DESCRIPTION	ANGULAR ±1/2°	DRAFT WHERE APPLICABLE MUST REMAIN WITHIN DIMENSIONS		SEE CHART	

WIRE SIZE	MAX INSULATION	"A" ±.012 ±0.30	"C" ±.012 ±0.30	"D" ±.005 ±0.13	"E" ±.012 ±0.30	"G" ±.005 ±0.13	"H" ±.012 ±0.30
20-24	.073/1.85	.090/2.29	.100/2.54	.030/0.76 R.	.075/1.91	.025/0.64 R.	.082/2.08
26-30	.050/1.27	.075/1.91	.083/2.10	.025/0.64 R.	.058/1.47	.020/0.51 R.	.065/1.65
18 OR 0.75mm <sup>2</sup>	.073/1.85	.091/2.31	.099/2.51	.030/0.76 R.	.086/2.18	.029/0.74 R.	.094/2.39

MATERIAL NUMBER	PLATING	WIRE SIZE	FORM
43030-0001	A	20-24	CHAIN
43030-0002	B	20-24	CHAIN
43030-0003	C	20-24	CHAIN
43030-0004	A	26-30	CHAIN
43030-0005	B	26-30	CHAIN
43030-0006	C	26-30	CHAIN
43030-0007	A	20-24	LOOSE
43030-0008	B	20-24	LOOSE
43030-0009	C	20-24	LOOSE
43030-0010	A	26-30	LOOSE
43030-0011	B	26-30	LOOSE
43030-0012	C	26-30	LOOSE
43030-0038	A	18 OR 0.75mm <sup>2</sup> (SEE NOTE 10)	CHAIN

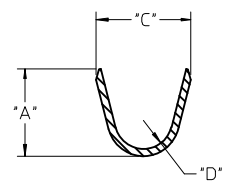
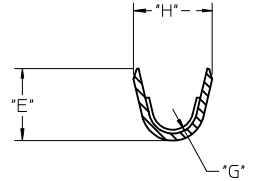

SECTION V-V

SECTION W-W

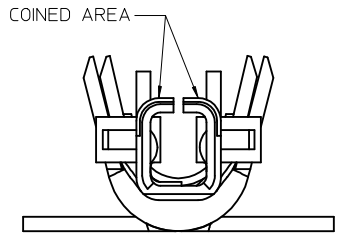
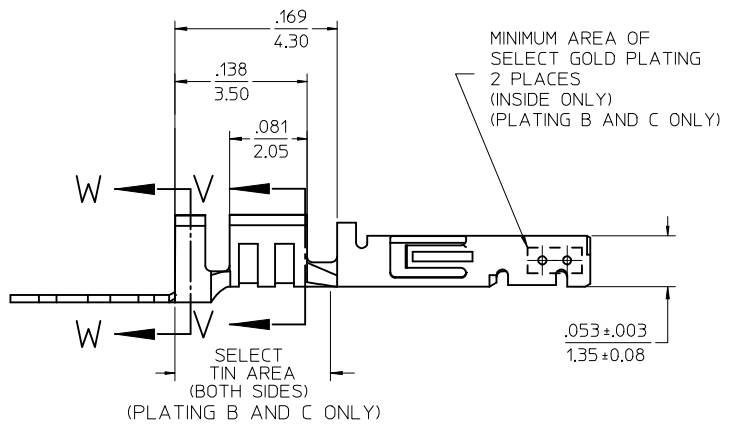
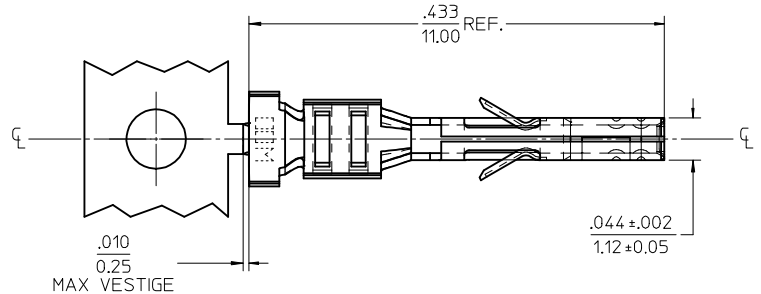

(SCALE 20:1)

NOTES

- MATERIAL: PHOSPHOR BRONZE ALLOY
- TERMINAL PLATING:
  - "A" - HOT TIN DIP: .000040/0.00102 MIN. OVERALL
  - "B" - .000015/0.00038 MIN. SELECT GOLD .000100/0.00254 MIN. SELECT TIN ALL OVER .000050/0.00127 MIN. NICKEL OVERALL.
  - "C" - .000030/0.00076 MIN. SELECT GOLD .000100/0.00254 MIN. SELECT TIN ALL OVER .000050/0.00127 MIN. NICKEL OVERALL.
- PRODUCT SPECIFICATION: PS-43045, PS-43650, PS-44300-001.
- PACKAGING SPECIFICATION: PK-43030-001 (REEL), PK-43030-003 (LOOSE).
- TERMINAL FOR USE IN A MICRO FIT RECEPTACLE #43025-\*\*\*\*, 43645-\*\*\*\*, AND 44133-\*\*\*\*.
- FOR TERMINAL ORIENTATION IN RECEPTACLE SEE DRAWING #SDA-43025 OR SDA-43645.
- THIS TERMINAL IS DESIGNED IN METRIC.
- MOLEX RECOMMENDS THE USE OF MICRO-FIT TEST PLUG (SERIES 44242) WHENEVER CONTINUITY TESTING IS PERFORMED. TEST PLUGS MUST NOT BE USED TO MAKE OR BREAK UNDER LOAD. MOLEX DOES NOT RECOMMEND USING STANDARD MATING COMPONENTS (SERIES 43020, 43045, 43640, 43650, OR 43031) FOR HARNESS TESTING PURPOSES.
- TEXT ON PART IS FOR REFERENCE ONLY. TEXT AND TEXT LOCATION MAY VARY DEPENDING ON PART NUMBER AND/OR TOOL.
- PART NUMBER 43030-0038 IS DESIGNED FOR 18 AWG 1061 STYLE WIRE OR A .073/1.85 MAXIMUM INSULATION OUTSIDE DIAMETER.

UPDATE FACTORY ID EC NO: UCP2017-2563 DRW:ZSHARPER 2017/05/30 CHKD: APPR:FSMLTH 2017/09/29	QUALITY SYMBOLS	GENERAL TOLERANCES (UNLESS SPECIFIED)	DIMENSION STYLE IN/MM	SCALE 10:1	DESIGN UNITS METRIC	THIRD ANGLE PROJECTION
	▽=0	4 PLACES ± --- ± ---	DRAWN BY MUELLER	DATE 2002/08/03	MICRO-FIT (3.0) FEMALE CRIMP TERMINAL  <b>molex</b> DOCUMENT NO. SD-43030-**** SHEET NO. 1 OF 1	
	▽=0	3 PLACES ± --- ±.010	CHECKED BY MUELLER	DATE 2002/08/03		
	▽=0	2 PLACES ±.025 ±.014	APPROVED BY MARGULIS	DATE 2002/08/03		
▽=0	1 PLACE ±.035 ± ---	MATERIAL NO.				
REV N6	DESCRIPTION	ANGULAR ±1/2°	DRAFT WHERE APPLICABLE MUST REMAIN WITHIN DIMENSIONS		SEE CHART	