



HESTORE.HU

elektronikai alkatrész áruház

EN: This Datasheet is presented by the manufacturer.

Please visit our website for pricing and availability at www.hestore.hu.

Pressure Sensor MPS20N0040D-S

This datasheet is provided by: e-radionica.com

support@e-radionica.com



<https://e-radionica.com/en/air-pressure-sensor-mps20n0040d-d.html>

Introduction

Pressure range :0-5 .8 psi (40kpa);

Product Features:

Solid, MEMS technology, high reliability

Low cost

Wide monitoring and control media

The application of a wide temperature range

Easy to use, choose from a variety of range. Easy to use, easy to install in OEM equipment

Application areas:

Automotive: tire pressure, car air pump, MAP sensor, diagnostic equipment, automotive sensors.

Industry: Air brake switch, portable pressure gauge, such as digital pressure gauge, environmental monitoring, consumer and sports

Health care: patient monitoring and diagnostic equipment, such as blood pressure monitors, medical instrumentation and monitoring

Range: 40kpa (differential pressure)

Output: mV signal

Electricity supply: 5VDC or constant current 1Ma

Linear accuracy: 0.25% FS

Measure the pressure range of 580 PSIG, 40KPaG

Max pressure capacity of three times the measuring range

Work power supply 5 VDC,

Input impedance of 4 - 6 K Ω

The output impedance of 4 - 6 K Ω

Operating temperature -40 - 85 ° C -40 ° F - +185 ° F

Storage Temperature -40 - 125 ° C -40 ° the F - +257 ° F

Accessible media, clean, dry, non-corrosive gases

Bias voltage \pm 25 mV

Full-scale output voltage 50 - 100 mV

Bridge Resistance to 4 - 6 K Ω

Linearity \pm 0.3% F.S.

Hysteresis \pm 0.7% F.S.

Bias Temperature coefficient \pm 0.08% of F.S. / °c

Temperature coefficient of sensitivity -0.21 % FS/ °c

Pressure Sensor MPS20N0040D-S

Circuit

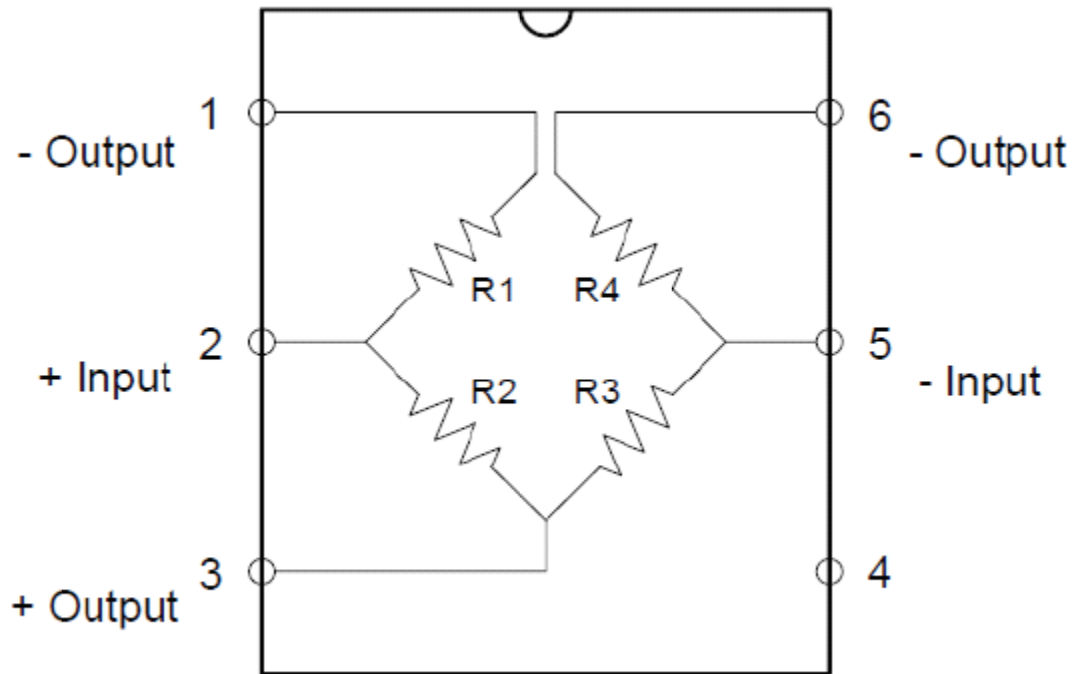

Difference Amplifier

This amplifier uses both inverting and non-inverting inputs with a gain of one to produce an output equal to the difference between the inputs. It is a special case of the differential amplifier. You can also choose the resistances to amplify the difference.

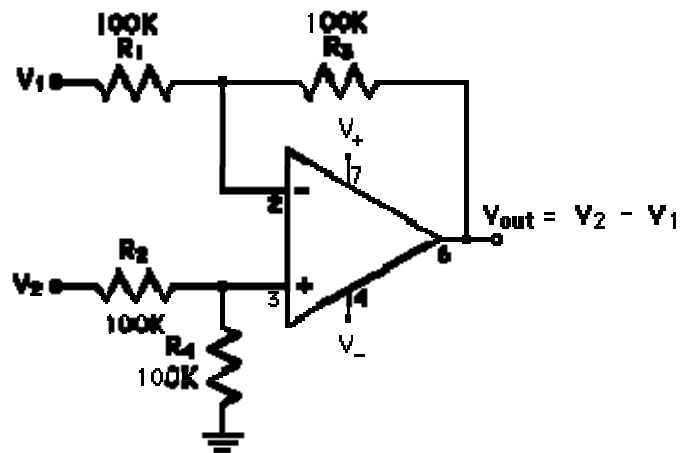

Pressure Sensor MPS20N0040D-S

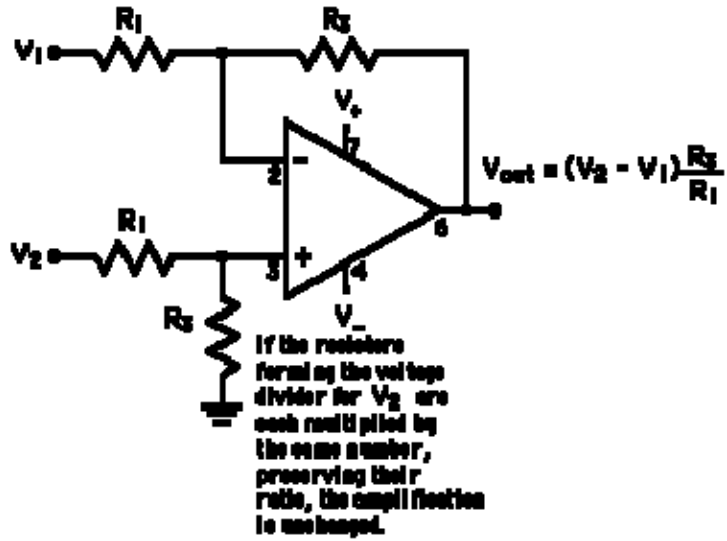

Dimensions

