



HESTORE.HU

elektronikai alkatrész áruház

EN: This Datasheet is presented by the manufacturer.

Please visit our website for pricing and availability at www.hestore.hu.

Cliff Electronic Components Ltd.

76 Holmethorpe Avenue, Holmethorpe Industrial Estate,

Redhill, Surrey, RH1 2PF, England, UK

Tel: 01737-771375 Fax: 01737-766012 Website: www.cliffuk.co.uk

Features

- High PD sensitivity for red light
- High speed up to 16 Mbps
- Low power consumption and current dissipation
- +3~+5V power source

Descriptions

The light receiving unit is a standard-package product with connector and opto-electric component packaged with PD and I/V amplifier IC. The function of unit changes the light signal into electric signal.

The unit is operated at +3~+5V and the input signal is TTL compatible. The DLR1121 has a maximum operating speed of 16 Mbps.

Applications

- Audio equipment
- Digital optical data link
- MD
- Sound card



Device Selection Guide

Chip		Operating Voltage (Vcc)	Dissipation Current(mA) Typ.	Fiber Coupling Light Output (dBm)		
IC Material	LED λ p(nm)			Min.	Typ.	Max.
Si	650	2.7~5.5	6.5	-24	-	-14.5

Package Dimensions

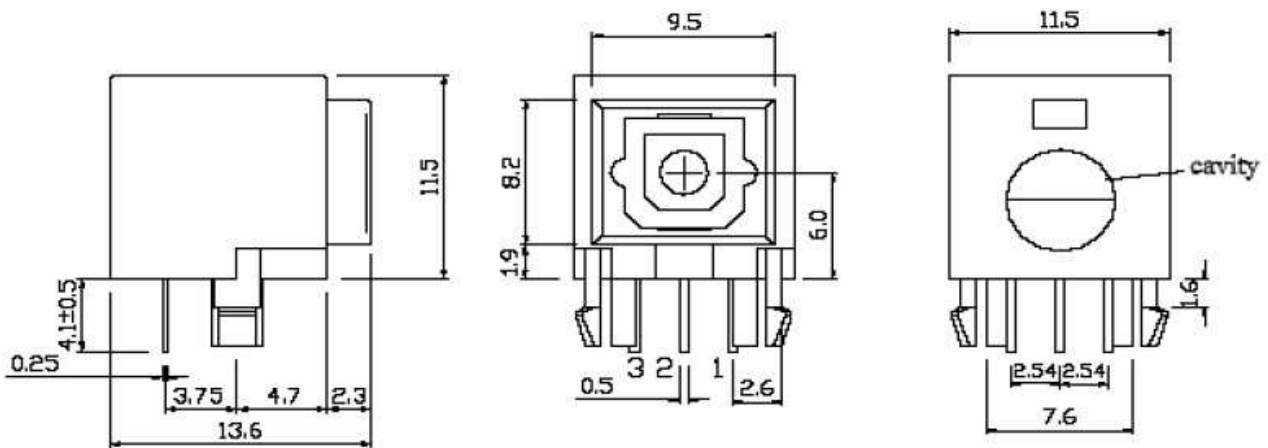

Notes: 1. All dimensions are in millimeters.
 2. General Tolerance: ± 0.2 mm

Pin Function

1. Vout
2. GND
3. Vcc

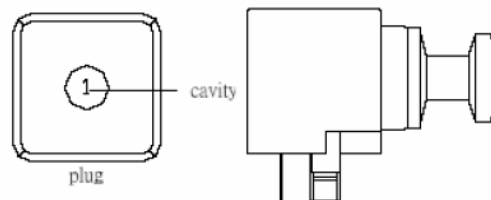

Absolute Maximum Ratings(Ta = 25°C)

Parameter	Symbol	Rating	Unit
Supply Voltage	Vcc	5.5	V
Storage Temperature	Tstg	-30 to 80	°C
Operating Temperature	Topr	-20 to 70	°C
Soldering Temperature	Tsol	260*	°C

* Soldering time ≤ 5 s / 2 times.

*Don't touch flux soldering and white Gas

Electro-Optical Characteristics

Parameter	Symbol	Conditions	MIN.	TYP.	MAX.	Unit
Operating Voltage	V _{cc}	-	2.7	-	5.5	V
Peak Detective Wavelength	λ_p	-	-	650	-	nm
Transfer Speed		NRZ signal	0.1	-	16	Mbps
Receiving Distance		Using APF	0.2	-	20	m
Pulse Width Distortion	Δtw	16Mbps NRZ Signal	-20	-	20	ns
Input Light power	P _i	*1	-24	-	-14.5	dBm
Dissipation Current	I _{cc}	*2	-	6	10	mA
High Level Output Voltage	V _{OH}		2.4	-	-	v
Low Level Output Voltage	V _{OL}		-	-	0.4	v
Rise Time	t _r	*3	-	-	25	ns
Fall Time	t _f	*3	-	-	25	ns
Low → High propagation delay time	t _{PLH}	*3	-	-	100	ns
High → Low propagation delay time	t _{PHL}	*3	-	-	100	ns
Jitter time	Δt_j	*3	-	1.5	15	ns

00H • 00H111175V • light receiving unit satisfies EIAJ CP-1201 digital audio interface standard.

Cliff Electronic Components Ltd.

76 Holmethorpe Avenue, Holmethorpe Industrial Estate,
Redhill, Surrey, RH1 2PF, England, UK

Tel: 01737-771375 Fax: 01737-766012 Website: www.cliffuk.co.uk

Reliability Test Items

No.	Item	Test Condition	Test Hour/Cycle	Samples	Number (n) Failure (c)
1	Soldering Heat	260°C±5°C	5 sec./2times	22	n=22, c=0
2	High temp. & Hum. storage	Ta=40°C, 90%RH	500	22	n=22, c=0
3	High temp. storage	Ta=80°C	500	22	n=22, c=0
4	Low Temp. storage	Ta=-30°C	500	22	n=22, c=0
5	Temp. cycling	-30°C ~ 80°C (30min) (5min) (30min)	20	22	n=22, c=0
6	High Temp. Operation life	Ta=60°C, Vcc=5V ON	500	22	n=22, c=0
7	Repeated operation	500 times	Coupling force < 2 kg 0.4kg<Detaching force <2kg	22	n=22, c=0
8	Terminal Strength(tension)	Weight: 500 g 30 sec./each terminal		22	n=22, c=0
9	Terminal Strength(bending)	Weight: 500 g 2 times/each terminal		22	n=22, c=0
10	Mechanical Shock	Acceleration: 1000m/s ² Pulse width: 6 ms 3 times/ X,Y,Z direction		22	n=22, c=0
11	Vibration	Frequency range: 10~55 Hz /sweep 1 min Overallamplitude:1.5 mm 2H./X,Y,Z direction		22	n=22, c=0

I_{cc} (dissipation current): CURRENT ATTENUATE DIFFERENCE < 20%

T_{PLH} (propagation L → H delay time): DELAY TIME DIFFERENCE < 20%

T_{PHL} (propagation H → L delay time): DELAY TIME DIFFERENCE < 20%

T_r (rise time): TIME DIFFERENCE < 20%

Tf (fall time): TIME DIFFERENCE < 20%

Measuring Method

*1 Maximum receiver input optical power/Minimum receiver input optical power

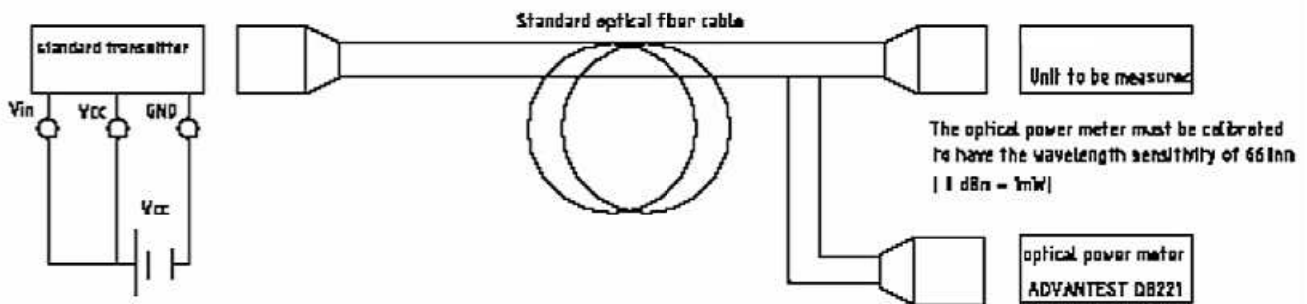

*2 Current dissipation measuring method

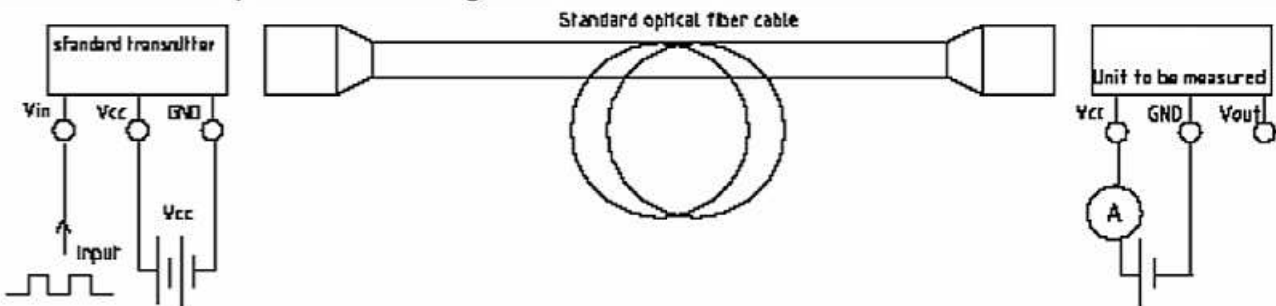

*3 Pulse response and jitter measuring method

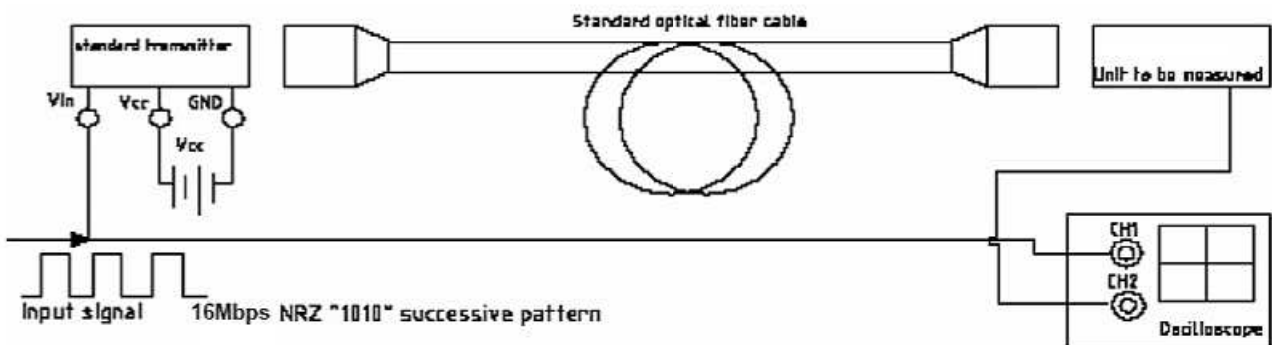

PCB Layout For Electrical Circuit

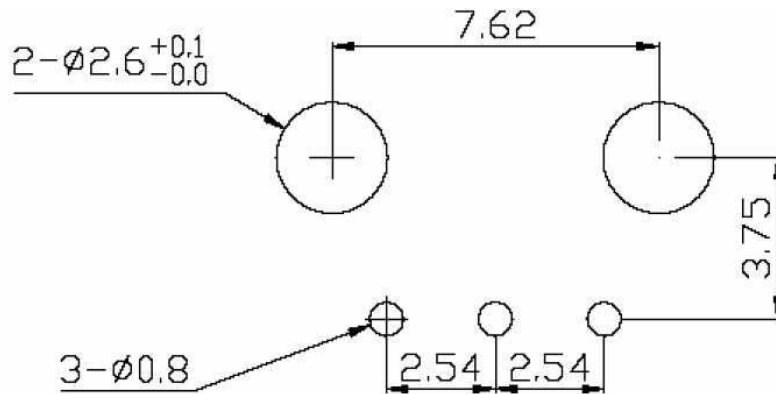

Notes:

1. Unit: mm
2. Unspecified tolerance: ± 0.3 mm
3. Substrate Thickness: 1.6mm

Precautions for Using Method

1. Connect a by-pass capacitor (0.1 μ F) close to V_{CC} within 7 mm of the unit lead frame.
2. Connect a by-pass capacitor (30pF) between GND and Vout avoid loading effect.
3. Take proper electrostatic-discharge (ESD) precautions while handling these devices. These devices are sensitive to ESD.

