



HESTORE.HU

elektronikai alkatrész áruház

EN: This Datasheet is presented by the manufacturer.

Please visit our website for pricing and availability at www.hestore.hu.

Ceramic Capacitor CCH series

- Appearance, Size and Structure

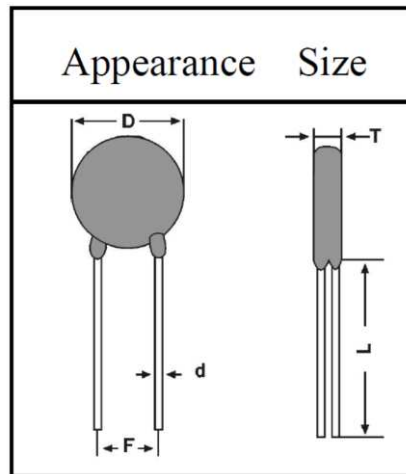

PN	Specification			L	D	T	F	d
	Volt	Cap.	Material	(mm)	Max(mm)	Max(mm)	(mm)	(mm)
CCH-100P/1000V	1kV	100 pF	SL	19 Min	7	2.5	5±0.5	0.45±0.05
CCH-1N/1000V		1 nF	Y5P	25 Min	7	3.5	5± 0.5	0.5±0.05
CCH-2N2/1000V		2,2 nF	Y5P	25 Min	9.5	3.5	5±0.5	0.5±0.05
CCH-4N7/1000V		4,7 nF	Y5P	25 Min	12.5	5	3	0.5±0.05

PN	Specification			L	D	T	F	d
	Volt	Cap.	Material	(mm)	Max(mm)	Max(mm)	(mm)	(mm)
CCH-100P/2000V	2kV	100 pF	YL	25 Min	7	4	5±0.5	0.6±0.05
CCH-10N/2000V		10 nF	Y5V	25 Min	11.5	4.5	7.5±0.5	0.6±0.05
CCH-1N/2000V		1 nF	Y5P	25 Min	8.5	4	5±0.5	0.6±0.05
CCH-1N5/2000V		1,5 nF	Y5P	25 Min	10	4	7.5±0.5	0.6±0.05
CCH-470P/2000V		470 pF	Y5P	25 Min	7	4	5±0.5	0.6±0.05

PN	Specification			L	D	T	F	d
	Volt	Cap.	Material	(mm)	Max(mm)	Max(mm)	(mm)	(mm)
CCH-100P/3000V	3kV	100 pF	Y5P	25 Min	7	4	7.5±0.5	0.6±0.05
CCH-10N/3000V		10 nF	Y5V	25 Min	15	5.5	7.5±0.5	0.6±0.05
CCH-150P/3000V		150 pF	Y5P	25 Min	8	4.5	7.5±0.5	0.6±0.05
CCH-1N/3000V		1 nF	Y5P	25 Min	11	5	7.5±0.5	0.6±0.05
CCH-1N5/3000V		1,5 nF	Y5P	25 Min	10	4.5	7.5±0.5	0.6±0.05
CCH-220P/3000V		220 pF	Y5P	25 Min	8	4.5	7.5±0.5	0.6±0.05
CCH-2N2/3000V		2,2 nF	Y5P	25 Min	13	7.5	4±0.5	0.6±0.05
CCH-3N3/3000V		3,3 nF	Y5P	25 Min	14.5	7.5	4±0.5	0.6±0.05
CCH-470P/3000V		470 pF	Y5P	25 Min	9	4.5	7.5±0.5	0.6±0.05
CCH-4N7/3000V		4,7 nF	Y5U	25 Min	13	5.5	7.5±0.5	0.6±0.05

PN	Specification			L	D	T	F	d
	Volt	Cap.	Material	(mm)	Max(mm)	Max(mm)	(mm)	(mm)
CCH-100P/6000V	6kV	100 pF	Y5P	25 Min	8	4	10±0.5	0.6±0.05
CCH-1N/6000V		1 nF	Y5P	25 Min	13	5.5	10±0.5	0.6±0.05
CCH-220P/6000V		220 pF	Y5P	25 Min	8	4	10±0.5	0.6±0.05
CCH-470P/6000V		470 pF	Y5P	25 Min	10	4.5	10±0.5	0.6±0.05
CCH-4N7/6000V		4,7 nF	Y5V	25 Min	13	5.5	10±0.5	0.6±0.05

▪ Capacitance and Temperature Curve

Material	Temperature Range	Capacitance Range
NPO	-25°C~+85°C	0±60PPM/°C
SL	-25°C~+85°C	+300~-1000PPM/°C
Y5P	-25°C~+85°C	+10%~-10%
Y5U	-25°C~+85°C	+22%~-56%
Y5V	-25°C~+85°C	+22%~-82%

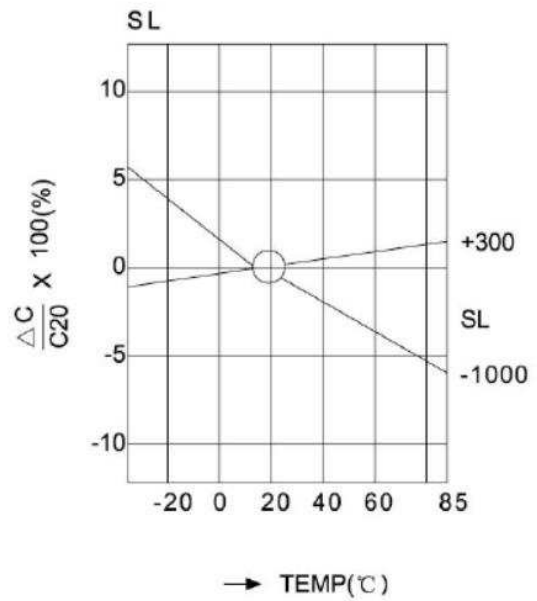
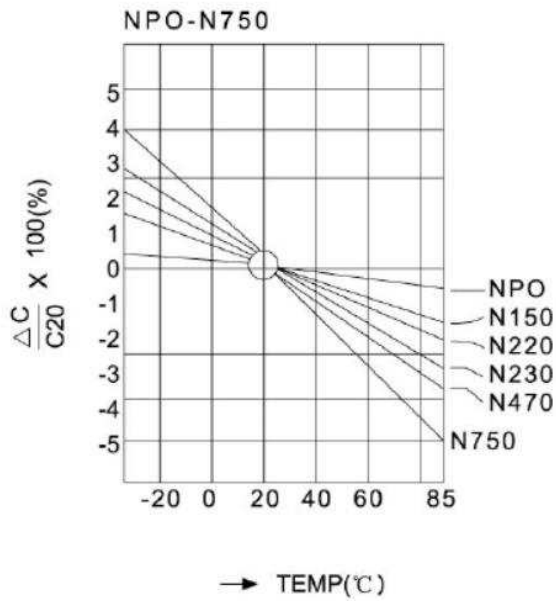

Capacitance Temperature Characteristics (H1-K) II类

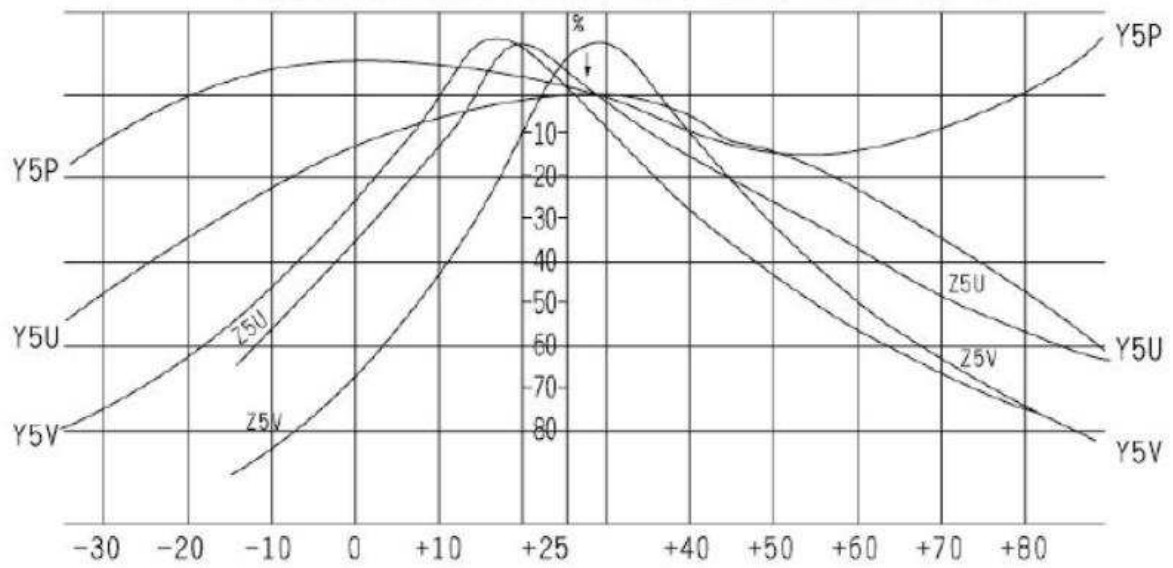

▪ **According to: Specification**

- GB/T 2693 《Fixed capacitors for use in electronic equipment
Part1: Generic specification》
- GB/T 5966 《Fixed capacitors for use in electronic equipment
Part8: Sectional specification
Fixed capacitors of ceramic dielectric, Class I 》
- GB/T 5968 《Fixed capacitors for use in electronic equipment
Part8: Sectional specification
Fixed capacitors of ceramic dielectric, Class II 》
- GB 11305 《Fixed capacitors for use in electronic equipment
Sectional specification
Fixed capacitors of ceramic dielectric, Class III 》
- GB/T 14472 《Fixed capacitors for use in electronic equipment
Part14: Sectional specification
Fixed capacitors for electromagnetic interference suppression and
connection to the supply mains》
- GB2828 《Sampling procedures and tables for lot-by-lot inspection
by attributes》
- GB2829 《Sampling procedures and tables for periodic inspection by attributes》

▪ **Quality Assurance(OQC)and Test**

Check item (lot)	Check level	
	IL	AQL
1. Appearance 2. Size	S--4	2.5
1. Capacitance 2. DF 3. Voltage proof 4. Insulation resistance	II	0.25
1. Solder ability of leads	S--3	2.5

▪ Specification and Testing Method

Item	Specification	Testing Method												
1.Operating Temperature Range	-25 ~ +85°C													
2.Capacitance	K : ±10% M : ±20% Z : +80%/-20%	Temperature : 25±2°C Voltage : 1.0±0.2Vrms Frequency : 1.0±0.2KHz												
3.DF	Y5P:2.5%max Y5U:2.5%max Y5V:5.0%max	Temperature : 25±2°C Voltage : 1.0±0.2Vrms Frequency : 1.0±0.2KHz												
4.Insulation Resistance(IR)	5000MΩmin	Apply voltage : U=500V Apply current : I≤0.05A Test time : 1min												
5.Dielectric Strength	Nofailure	Ratedvoltage : $U_R > 500V$, Testvoltage $U = 1.5U_R$ Applycurrent : I≤0.05A, Testtime : 1min												
6.Temperature Characteristic	Y5P : +10% ~ -10% Y5U : +22% ~ -56% Y5V : +22% ~ -82% NPO : 0±60PPM/°C SL : +30-1000PPM/°C	The capacitance measurement shall be made at each step : Before Test : Set the capacitor for 1 hour at 85±2°C, after 24±2 hour at room temperature, then can be measured. <table> <thead> <tr> <th>Step</th> <th>Temperature</th> </tr> </thead> <tbody> <tr> <td>1</td> <td>20±2°C</td> </tr> <tr> <td>2</td> <td>-25±3°C</td> </tr> <tr> <td>3</td> <td>20±2°C</td> </tr> <tr> <td>4</td> <td>85±2°C</td> </tr> <tr> <td>5</td> <td>20±2°C</td> </tr> </tbody> </table>	Step	Temperature	1	20±2°C	2	-25±3°C	3	20±2°C	4	85±2°C	5	20±2°C
Step	Temperature													
1	20±2°C													
2	-25±3°C													
3	20±2°C													
4	85±2°C													
5	20±2°C													

Item	Specification	Testing Method	
7.Vibration resistance	Appearance	No marked defect	The capacitor shall firmly be soldered to the supporting terminal and vibration which is 10HZ to 55HZ in the vibration frequency range 1.5mm in total amplitude and about 1min.in the rate of vibration change from 10HZ to 55HZ and back to 10HZ is applied for a total of 6 hours, 2hours each in there mutually perpendicular direction.
	Capacitance	Y5P : $\Delta C/C \leq 10\%$ Y5V : $\Delta C/C \leq 30\%$ Y5U : $\Delta C/C \leq 20\%$	
	DF	Y5P : 5.0%max Y5V : 5.0%max Y5U : 5.0%max	
8.Soldering effect	Appearance	No marked defect	The lead wire shall be immersed into the melted solder of 260+50C up to about 1.5to 2.0mm from the main body for 3.5+0.5sec. Pre-treatment : capacitor shall be stored 1hour at 85±2°C after at normal temperature for 24±2 hour before initial measurements. Post-treatment : capacitor shall be measured after 24±2 hours at normal temperature.
	Capacitance	Y5P : $\Delta C/C \leq 10\%$ Y5V : $\Delta C/C \leq 30\%$ Y5U : $\Delta C/C \leq 20\%$	
	Dielectric strength (between lead wires)	No failure	
9.Humidity (under steady state)	Appearance	No marked defect	Set the capacitor for 500 hours at 40+20C in 90 to 95%RH Pre-treatment : capacitor shall be stored 1hour at 85±2°C after at normal temperature for 24±2 hour before initial measurements. Post-treatment : capacitor shall be measured after 24±2 hours at normal temperature.
	Capacitance change	Y5P : $\Delta C/C \leq 10\%$ Y5V : $\Delta C/C \leq 30\%$ Y5U : $\Delta C/C \leq 20\%$	
	DF	Y5P : 5.0%max Y5V : 5.0%max Y5U : 5.0%max	
	Insulation Resistance (IR)	500MΩmin	

Item	Specification	Testing Method	
10. Humidity loading	Appearance	No marked defect	Apply rated voltage for 500 hours at 40±2°C in 90 to 95%RH Pre-treatment : capacitor shall be stored 1hour at 85±2°C after at normal temperature for 24±2 hour before initial measurements. Post-treatment : capacitor shall be measured after 24±2 hours at normal temperature.
	Capacitance change	Y5P : $\Delta C/C \leq 10\%$ Y5V : $\Delta C/C \leq 30\%$ Y5U : $\Delta C/C \leq 20\%$	
	DF	Y5P : 5.0%max Y5U : 5.0%max Y5V : 7.0%max	
	Insulation Resistance (IR)	1000MΩmin	
11. Life Test	Appearance	No marked defect	Apply 150% of the rated voltage for 1000 hours at 85±2°C Pre-treatment : capacitor shall be stored 1hour at 85±2°C after at normal temperature for 24±2 hour before initial measurements. Post-treatment : capacitor shall be measured after 24±2 hours at normal temperature.
	Capacitance change	Y5P : $\Delta C/C \leq 10\%$ Y5V : $\Delta C/C \leq 30\%$ Y5U : $\Delta C/C \leq 20\%$	
	DF	Y5P : 5.0%max Y5U : 5.0%max Y5V : 7.5%max	
	Insulation Resistance (IR)	1000MΩmin	
12. Strength of lead	Dielectric strength	Lead wire shall not cut off, Capacitor shall not be broken.	As a figure fix the body of capacitor, apply a tensile weight gradually to each lead in the radial direction of capacitor up to 10N and keep it for 10±15 sec.
	Bending		Each lead wire shall be subjected to 5N weight and then ±45° bend twice.
	Turn back strength		Each lead wire shall be turn back twice at 180°.
13. Solderability of leads	Lead wire shall be soldered with coated over 95% of the circumferential direction	The lead wire of a capacitor shall be dipped into flux and then into molten solder of 235±5°C for 2±0.5sec.	