



**HESTORE.HU**

elektronikai alkatrész áruház

**EN:** This Datasheet is presented by the manufacturer.

Please visit our website for pricing and availability at [www.hestore.hu](http://www.hestore.hu).

# Low-Power, Slew-Rate-Limited RS-485/RS-422 Transceivers MAX485

## DESCRIPTION

The MAX485 is a half-duplex transceiver that meets the specifications of RS-485 and RS-422. Its BiCMOS design allows low power operation without sacrificing performance. The MAX485 meets the requirements of the RS-485 and RS-422 protocols up to 5Mbps underload. The ESD tolerance is more than  $\pm 8\text{kV}$  for both Human Body Model and  $\pm 15\text{kV}$  for IEC61000-4-2 Air Discharge Method on this device.

## FEATURES

- Single +5V Supply
- Low Power BiCMOS
- Driver/Receiver Enable for Multi-Drop Configurations
- Half-Duplex Versions Available
- Data rate: 5 Mbps
- ESD Specifications
  - $\pm 15\text{kV}$  IEC61000-4-2 Air Discharge
  - $\pm 8\text{kV}$  Human Body Model

## APPLICATIONS

- Low Power RS-485 Systems
- DTE-DCE Interface
- Packet Switching
- Local Area Networks
- Data Concentration
- Data Multiplexers
- Integrated Services Digital Network (ISDN)

## PIN CONFIGURATION AND LOGIC DIAGRAM

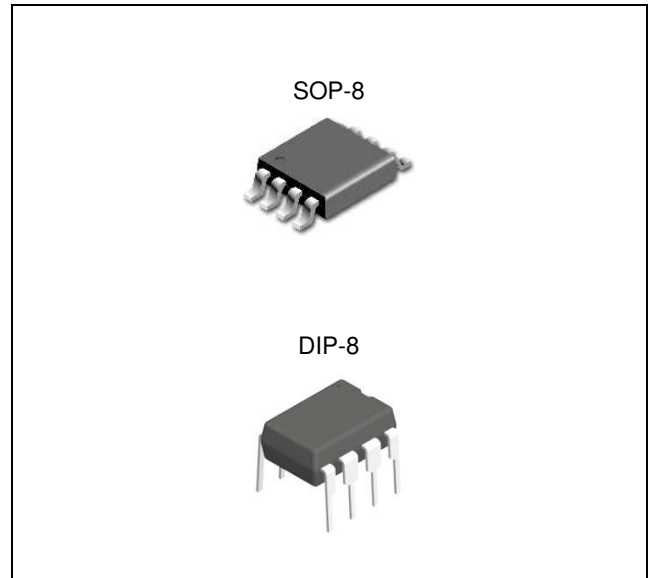
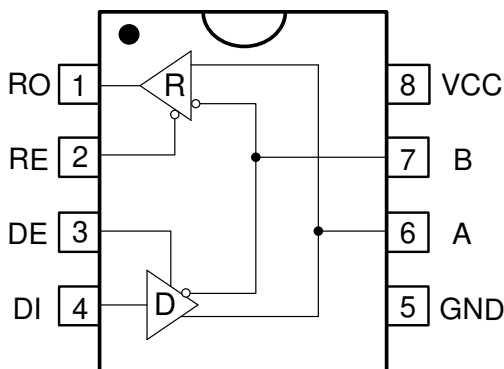

## TRUTH TABLE

Transmission				
Inputs			Outputs	
RE	DE	DI	A	B
X	1	1	1	0
X	1	0	0	1
0	0	X	Z	Z
1	0	X	Z	Z
Receiver				
Inputs			Outputs	
RE	DE	A-B	RO	
0	0	$\geq +0.2\text{V}$	1	
0	0	$\leq -0.2\text{V}$	0	
0	0	Open	1	
1	0	X	Z	

# Low-Power, Slew-Rate-Limited RS-485/RS-422 Transceivers **MAX485**

## ORDERING INFORMATION

Package	Oder No.	Description	Marking	Compliance	Status
SOP-8	MAX485ED	RS-485/RS-422 Transceivers	MAX485E	RoHS, Green	Active
DIP-8	MAX485EN	RS-485/RS-422 Transceivers	MAX485E	RoHS, Green	Contact us

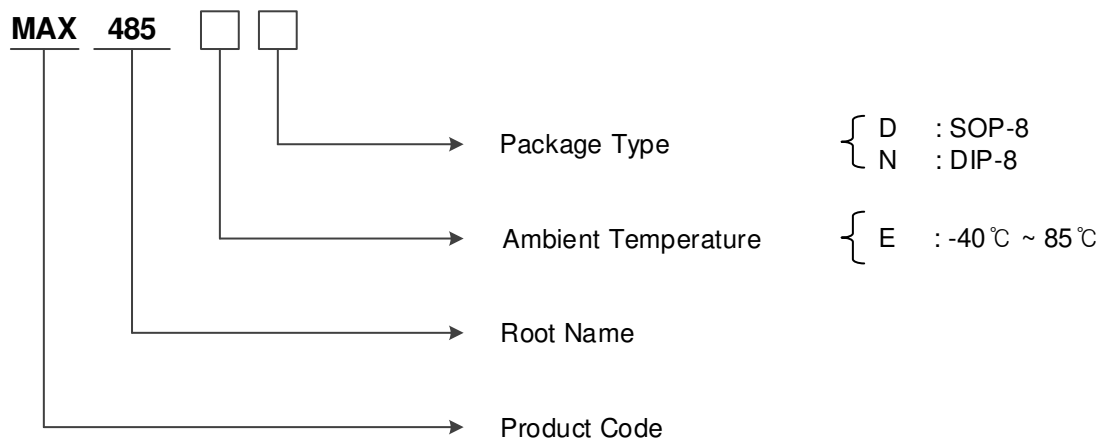

## Low-Power, Slew-Rate-Limited RS-485/RS-422 Transceivers MAX485

### ABSOLUTE MAXIMUM RATINGS

Characteristic	Symbol	Min	Max	Unit
Supply Voltage	$V_{CC}$		7	V
Control Input Voltage	$V_{DE}, V_{RE}$	-0.3	$V_{CC} + 0.5$	V
Driver Input Voltage	$V_{DI}$	-0.3	$V_{CC} + 0.5$	V
Driver Output Voltage	A, B	-15	15	V
Receiver Input Voltage	A, B	-15	15	V
Receiver Output Voltage	$V_{RO}$	-0.3	$V_{CC} + 0.5$	V
Junction Temperature	$T_J$	-40	125	°C
Storage Temperature Range	$T_{STG}$	-65	150	°C

### RECOMMENDED OPERATING CONDITIONS

Characteristic	Symbol	Min	Max	Unit
Supply Voltage	$V_{CC}$	4.75	5.25	V
Operating Ambient Temperature Ranges	$T_A$	-40	85	°C

# Low-Power, Slew-Rate-Limited RS-485/RS-422 Transceivers **MAX485**

## PIN CONFIGURATION

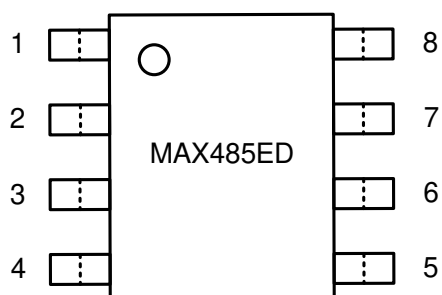

SOP-8

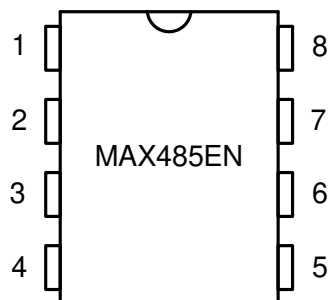

DIP-8

## PIN DESCRIPTION

Pin No.	SOP-8 / DIP-8 PKG	
	Name	Function
1	RO	Receiver Output
2	RE*	Receiver Output Enable Active Low
3	DE	Driver Output Enable Active High
4	DI	Driver Input
5	GND	Ground
6	A	Non-inverting Driver Output and Receiver Input
7	B	Inverting Driver Output and Receiver Input
8	V <sub>CC</sub>	Power Supply: 4.75V to 5.25V

# Low-Power, Slew-Rate-Limited RS-485/RS-422 Transceivers **MAX485**

## ELECTRICAL CHARACTERISTICS

Unless otherwise specified:  $V_{CC} = 5V \pm 5\%$ ,  $T_A = T_{MIN}$  to  $T_{MAX}$

PARAMETER	Symbol	CONDITIONS	MIN	TYP	MAX	UNITS
<b>DRIVER DC Characteristics</b>						
Differential Driver Output (no load)	$V_{OD1}$	$R_L = \infty$ , Figure 1	GND		$V_{CC}$	V
Differential Driver Output (with load)	$V_{OD2}$	$R_L = 50\Omega$ (RS-422), Figure 1	2		$V_{CC}$	V
		$R_L = 27\Omega$ (RS-485), Figure 1	1.5		$V_{CC}$	
Change in Magnitude of Driver Differential Output Voltage for Complementary Output States	$\Delta V_{OD}$	$R_L = 27\Omega$ or $50\Omega$ , Figure 1			0.2	V
Driver Common-Mode Output Voltage	$V_{OC}$	$R_L = 27\Omega$ or $50\Omega$ , Figure 1			3	V
Change in Magnitude of Driver Common-Mode Output Voltage for Complementary Output States	$\Delta V_{OC}$	$R = 27\Omega$ or $50\Omega$ , Figure 1			0.2	V
Input High Voltage	$V_{IH}$	DE, DI, RE*	2.0			V
Input Low Voltage	$V_{IL}$	DE, DI, RE*			0.8	V
Input Current	$I_{IN1}$	DE, DI, RE*			$\pm 10$	$\mu A$
<b>Driver Short Circuit Current</b>						
Driver Short-Circuit Current, $V_O = \text{High}$	$I_{OSD1}$	$-7V \leq V_O \leq 12V$			$\pm 250$	mA
Driver Short-Circuit Current, $V_O = \text{Low}$	$I_{OSD2}$	$-7V \leq V_O \leq 12V$			$\pm 250$	mA
<b>DRIVER AC Characteristics</b>						
Max. Transmission Rate	$f_{MAX}$		5			Mbps
Driver Input to Output	$t_{DPLH}$	Figure 3 & 5 $R_L = 54\Omega$ , $C_{L1} = C_{L2} = 100pF$		30	60	ns
	$t_{DPHL}$			30	60	ns
Driver Output Skew to Output	$t_{SKEW}$			5	10	ns
Driver Rise or Fall Time	$t_r, t_f$			15	40	ns
Driver Enable to Output High	$t_{ZH}$		Figure 4 & 6 $C_L = 100pF$	$S_2$ closed	40	70
Driver Enable to Output Low	$t_{ZL}$	$S_1$ closed		40	70	ns
Driver Disable Time from Low	$t_{HZ}$	$S_2$ closed		40	70	ns
Driver Disable Time from High	$t_{LZ}$	$S_1$ closed		40	70	ns
<b>RECEIVER DC Characteristics</b>						
Receiver Differential Threshold Voltage	$V_{TH}$	$-7V \leq V_{CM} \leq 12V$	-0.2		0.2	V
Receiver Input Hysteresis	$\Delta V_{TH}$	$V_{CM} = 0V$		20		mV
Receiver Output High Voltage	$V_{OH}$	$I_O = -4mA$ , $V_{ID} = +200mV$	3.5			V
Receiver Output Low Voltage	$V_{OL}$	$I_O = +4mA$ , $V_{ID} = -200mV$			0.4	V
Three-State (High Impedance) Output Current at Receiver	$I_{OZR}$	$0.4V \leq V_O \leq 2.4V$ , $RE^* = 5V$			$\pm 1$	$\mu A$
Receiver Input Resistance	$R_{IN}$	$-7V \leq V_{CM} \leq 12V$	12	15		k $\Omega$
Input Current (A, B)	$I_{IN2}$	$DE = 0V$	$V_{IN} = 12V$		1.0	mA
		$V_{CC} = 0V$ or $5.25V$	$V_{IN} = -7V$		-0.8	
Receiver Short-Circuit Current	$I_{OSR}$	$0V \leq V_O \leq V_{CC}$	7		95	mA

## Low-Power, Slew-Rate-Limited RS-485/RS-422 Transceivers **MAX485**

<b>RECEIVER AC Characteristics</b>							
Receiver Input to Output	t <sub>PLH</sub>	Figure 2 & 7 S <sub>1</sub> , S <sub>2</sub> open C <sub>L</sub> = 15pF		20	45	100	ns
	t <sub>PHL</sub>			20	45	100	ns
t <sub>PLH</sub> - t <sub>PHL</sub>   Differential Receiver Skew	t <sub>SKD</sub>					13	
Receiver Enable to Output Low	t <sub>ZL</sub>	Figure 2 & 8 C <sub>L</sub> = 15pF	S <sub>1</sub> closed		45	70	ns
Receiver Enable to Output High	t <sub>ZH</sub>		S <sub>2</sub> closed		45	70	ns
Receiver Disable Time from Low	t <sub>LZ</sub>		S <sub>1</sub> closed		45	70	ns
Receiver Disable Time from High	t <sub>HZ</sub>		S <sub>2</sub> closed		45	70	ns
<b>Supply Current</b>							
No-Load Supply Current	I <sub>CC</sub>	RE = 0V or V <sub>CC</sub>	DE=V <sub>CC</sub>		900		uA
			DE=0V		600		

TEST CIRCUITS

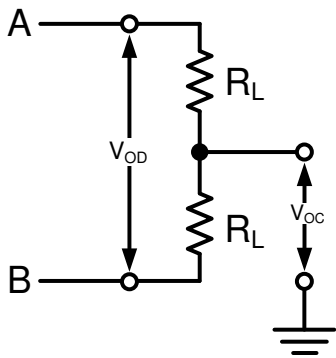

Figure 1.

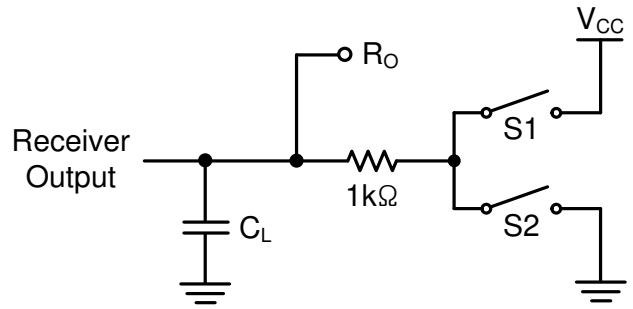

Figure 2.

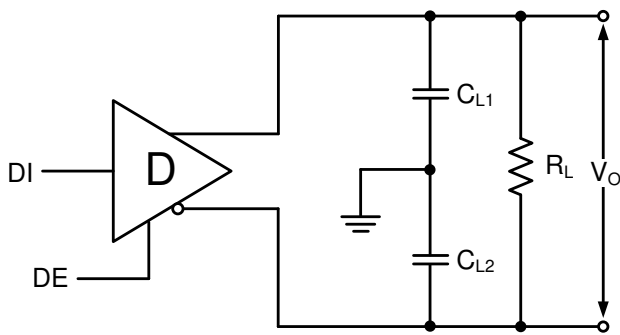

Figure 3.

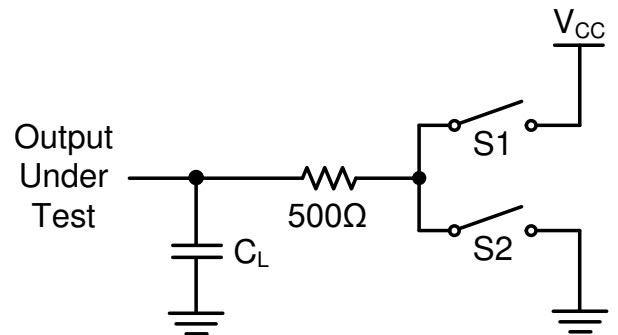

Figure 4.

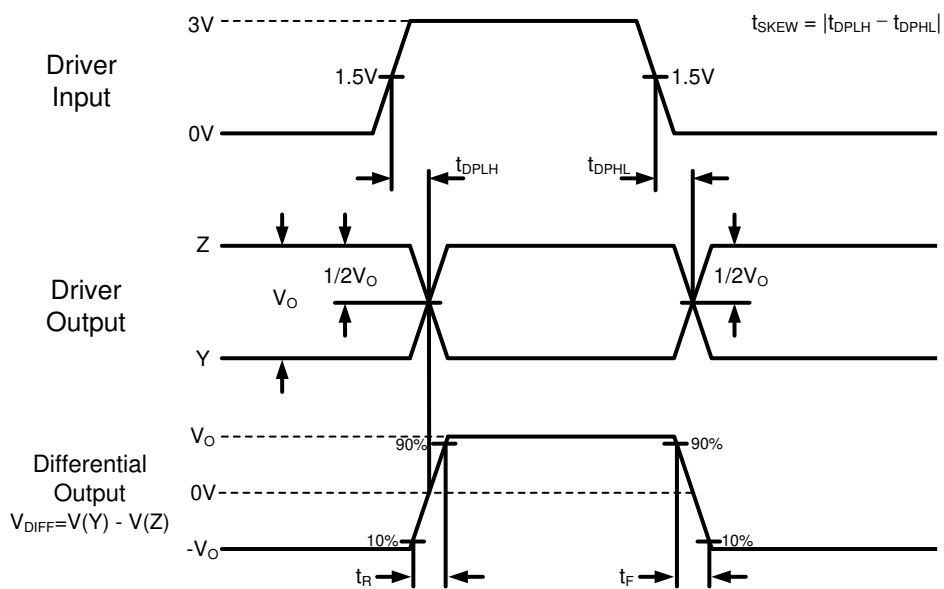

Figure 5.



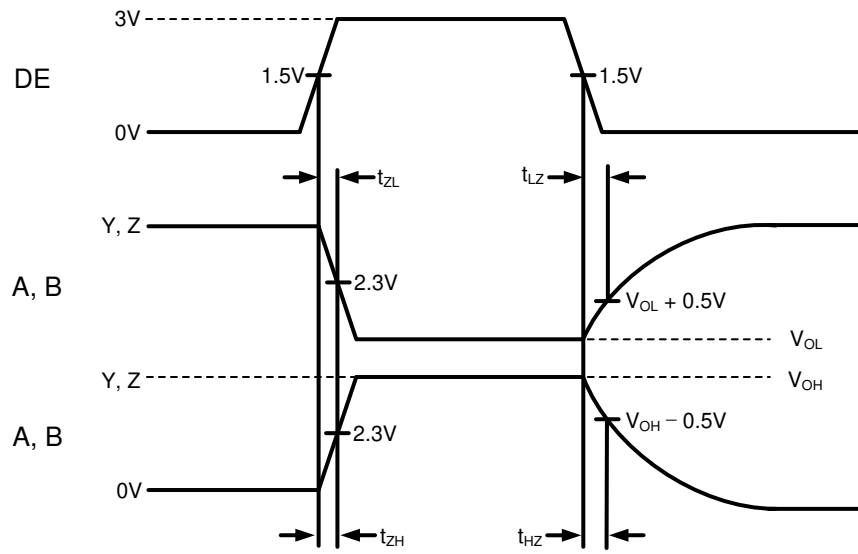

Figure 6.

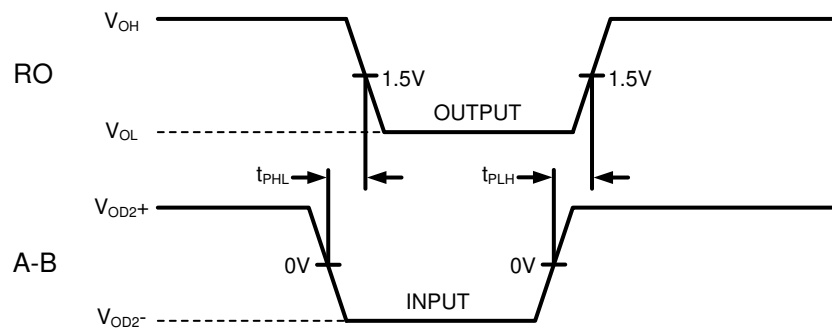

Figure 7.

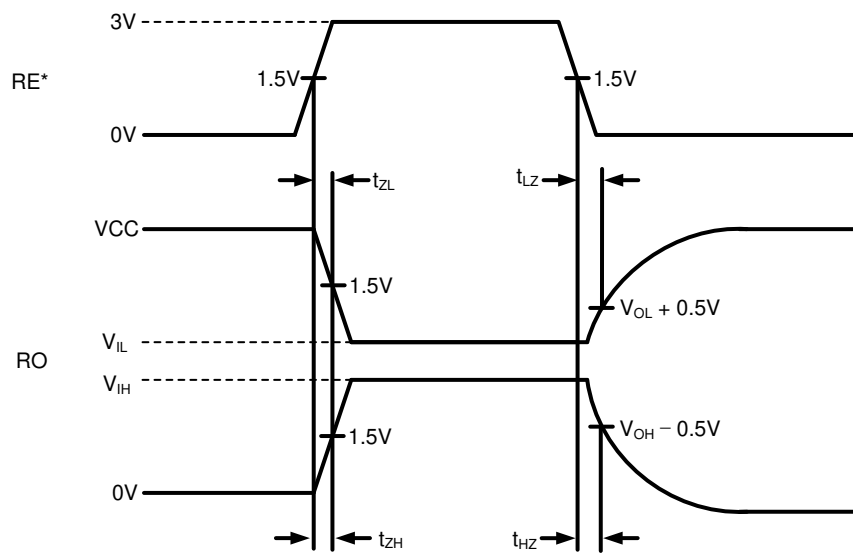

Figure 8.

## APPLICATION INFORMATION

### FUNCTIONAL DESCRIPTION

The MAX485 is half-duplex differential transceiver that meets the requirements of RS-485 and RS-422. The RS-485 standard is ideal for multi-drop applications and for long-distance interfaces. RS-485 allows up to 32 drivers and 32 receivers to be connected to a data bus, making it an ideal choice for multi-drop applications. Since the cabling can be as long as 4,000 feet, RS-485 transceivers are equipped with a wide (-7V to +12V) common mode range to accommodate ground potential differences. Because RS-485 is a differential interface, data is virtually immune to noise in the transmission line.

### DRIVERS

The driver outputs of the MAX485 are differential outputs meeting the RS-485 and RS-422 standards. The typical voltage output swing with no load will be 0 Volts to +5 Volts. With worst case loading of 54 $\Omega$  across the differential outputs, the drivers can maintain greater than 1.5V voltage levels. The drivers of the MAX485 have an enable control line which is active HIGH. A logic HIGH on DE (pin 3) will enable the differential driver outputs. A logic LOW on the DE(pin 3) will tri-state the driver output. The transmitters of the MAX485 will operate up to at least 5Mbps.

### RECEIVERS

The MAX485 receiver has differential inputs with an input sensitivity as low as  $\pm 200\text{mV}$ . Input impedance of the receivers is typically 15k $\Omega$  (12k $\Omega$  minimum). A wide common mode range of -7V to +12V allows for large ground potential differences between systems. The receivers of the MAX485 have a tri-state enable control pin. A logic LOW on RE\* (pin 2) will enable the receiver, a logic HIGH on RE\*(pin 2) will disable the receiver. The receiver for the MAX485 will operate up to at least 5Mbps. The receiver is equipped with the fail-safe feature. Fail-safe guarantees that the receiver output will be in a HIGH state when the input is left unconnected.

# **Low-Power, Slew-Rate-Limited RS-485/RS-422 Transceivers MAX485**

---

## **REVISION NOTICE**

The description in this datasheet can be revised without any notice to describe its electrical characteristics properly.