



HESTORE.HU

elektronikai alkatrész áruház

EN: This Datasheet is presented by the manufacturer.

Please visit our website for pricing and availability at www.hestore.hu.

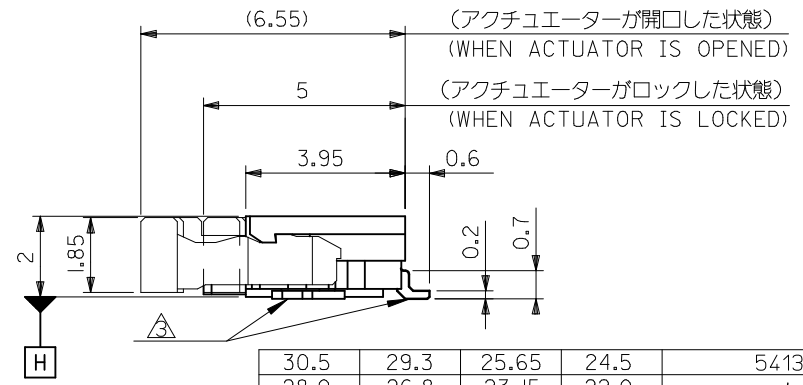
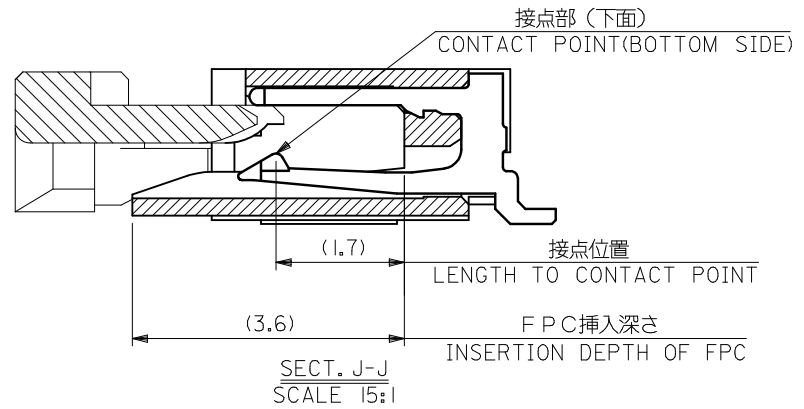
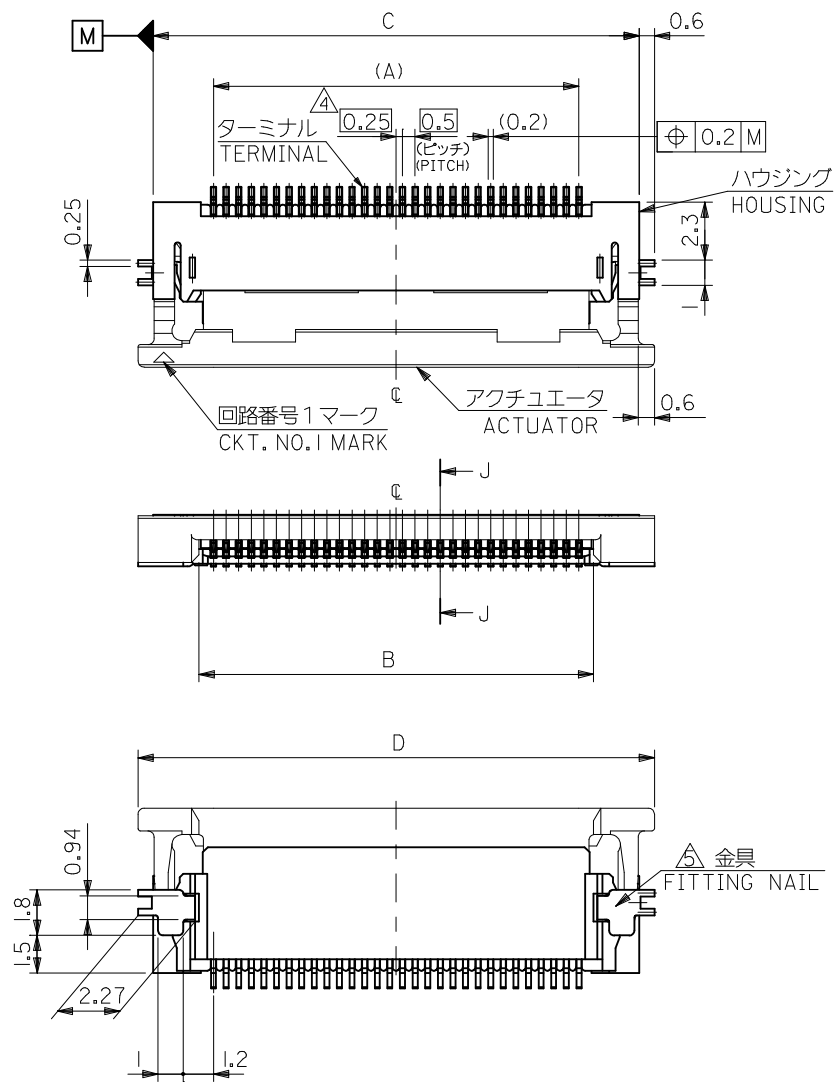

30.5	29.3	25.65	24.5	54132-5033	50
28.0	26.8	23.15	22.0	-4533	45
27.0	25.8	22.15	21.0	-4333	43
25.5	24.3	20.65	19.5	-4033	40
24.5	23.3	19.65	18.5	-3833	38
23.5	22.3	18.65	17.5	-3633	36
23.0	21.8	18.15	17.0	-3533	35
22.5	21.3	17.65	16.5	-3433	34
22.0	20.8	17.15	16.0	-3333	33
21.5	20.3	16.65	15.5	-3233	32
20.5	19.3	15.65	14.5	54132-3033	30
D	C	B	A	EMBOSSED PACKAGE	極数
				オーダー番号 ORDER No.	CKT.

CONNECTOR SERIES No. 54132-**22

REVISED EC NO: J2014-0096 DRW: AISHII 2013/07/18 CHK: KTAKAHASHI 2013/07/18 APPR: YNOGAWA 2013/08/19	GENERAL TOLERANCES (UNLESS SPECIFIED)		DIMENSION STYLE	SCALE	DESIGN UNITS	TITLE 0.5MM FPC CONN ZIF R/A HOUSING ASSY (LOWER CONTACT) molex DOCUMENT NO. SD-54132-066 SHEET NO. 1 OF 2
	10 UNDER ±0.2		MM ONLY	---	METRIC	
	10 OVER 30 UNDER ±0.25		DRAWN BY DATE	THIRD ANGLE PROJECTION		
	30 OVER ±0.3		AISHII 2012/09/03			
A	ANGULAR ±3 °		CHECKED BY DATE			
	DRAFT WHERE APPLICABLE MUST REMAIN WITHIN DIMENSIONS		KTAKAHASHI 2012/09/03			
			APPROVED BY DATE			
			KMORIKAWA 2013/04/16			
			MATERIAL NO.			
			SIZE			
			A3	THIS DRAWING CONTAINS INFORMATION THAT IS PROPRIETARY TO MOLEX INCORPORATED AND SHOULD NOT BE USED WITHOUT WRITTEN PERMISSION		

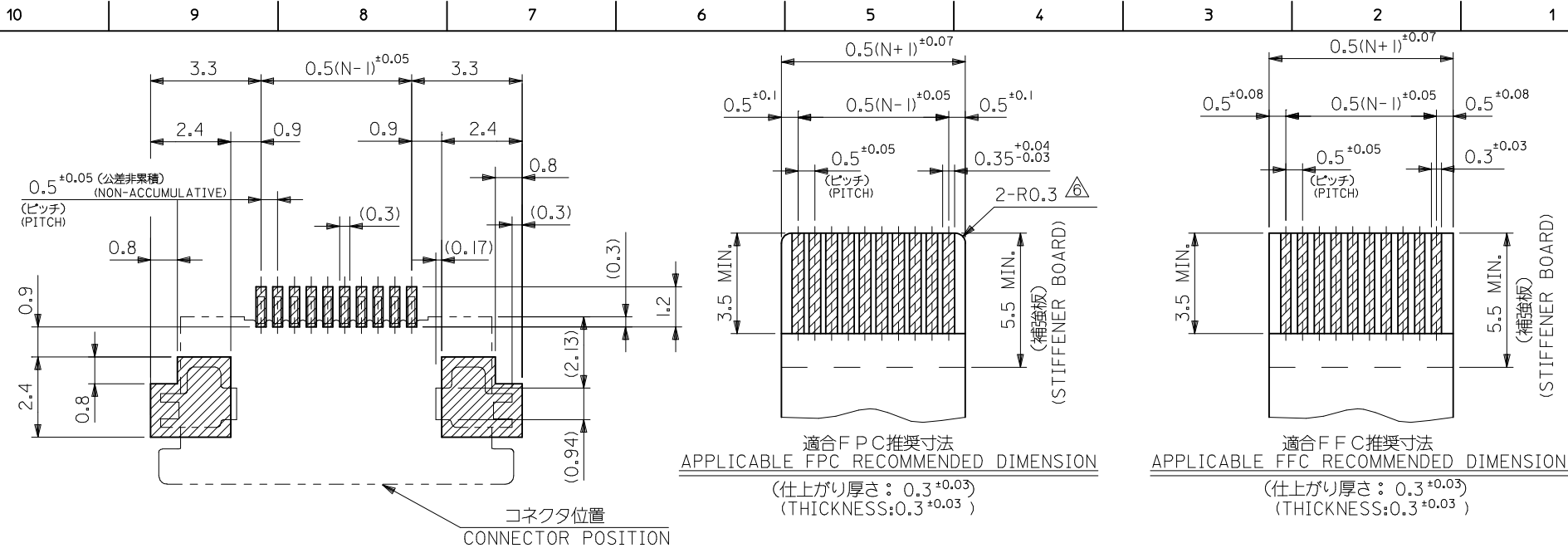

推奨基板レイアウト
RECOMMENDED PC BOARD PATTERN DIMENSION (REF.)
(マウント面)
(MOUNTING SIDE)

適合FPC推奨寸法
APPLICABLE FPC RECOMMENDED DIMENSION
(仕上がり厚さ: 0.3±0.03)
(THICKNESS: 0.3±0.03)

適合FFC推奨寸法
APPLICABLE FFC RECOMMENDED DIMENSION
(仕上がり厚さ: 0.3±0.03)
(THICKNESS: 0.3±0.03)

注記
NOTES

- 材質 MATERIAL
ハウジング: ポリアミド(PA)、ガラス充填、ナチュラル(白)、UL94V-0
HOUSING: POLYAMIDE, GLASS FILLED, NATURAL, UL94V-0
アクチュエータ: ポリフェニレンスルフィド(PFS)、ガラス充填、黒色、UL94V-0
ACTUATOR: POLYPHENYLENE SULFIDE, GLASS FILLED, BLACK, UL94V-0
ターミナル: リン青銅 (t = 0.2)
TERMINAL: PHOSPHOR BRONZE (t = 0.2)
金具: リン青銅 (t = 0.2)
NAIL: PHOSPHOR BRONZE (t = 0.2)
- めっき仕様 PLATING
ターミナル TERMINAL
鍍銀ビスマスキング (10 μm以上)
SILVER BISMUTH MASKING (10 μm MIN.)
下地: ニッケルめっき (10 μm以上)
UNDER PLATE: NICKEL PLATING (10 MICROMETER MINIMUM)
金具
鍍めっき (10 μm以上)
下地: ニッケルめっき (10 μm以上)
TIN PLATING (10 MICROMETER MINIMUM)
UNDER PLATE: NICKEL PLATING (10 MICROMETER MINIMUM)
- ソルダータール半田付け面のスレ量、及び金具半田付け面のスレ量は基準値 [] に対して上方0.1MAXIMUM、下方0.15MAXIMUMとする。
MISALIGNMENT OF SOLDER TAILS AND FITTING NAILS FROM []
UPPER DIRECTION: 0.1MAXIMUM
LOWER DIRECTION: 0.15 MAXIMUM.
- 偶数局に適用
APPLY FOR EVEN CIRCUIT.
- パターンはくり止め用金具
FITTING NAIL FOR PREVENTION OF PEELING OF P.C.B. PATTERN.
- R0.3はFPCの導体にかからないこと
R0.3 MUST NOT BE OVERLAPED TO PATTERN OF FPC.
- エンボスステップ幅時は、アクチュエータがロックした状態とする
IN THE PACKAGE, ACTUATOR SHOULD BE LOCKED.
- ELV及びRoHS適合品
ELV AND RoHS COMPLIANT.

FPC/FFCについて ABOUT FPC/FFC
打ち抜き方向は導体側から補強板側を推奨します。
導体側については軟線径35 μmまたは50 μmを推奨します。
RECOMMENDED PUNCHING DIRECTION:
FROM CONDUCTOR SIDE TO STIFFENER SIDE
RECOMMENDED CONDUCTOR SPEC:
SOFT COPPER FOIL
RECOMMENDED CONDUCTOR THICKNESS:
35 MICROMETER OR 50 MICROMETER

FPCについて ABOUT FPC
補強フィルム材質はポリイミドを推奨します。ベースフィルムは25 μmを推奨します。
接着剤は熱硬化接着剤を推奨します。
尚、接着剤の接点部への付着は導通不良の原因になりますので、染み出しが無い様、お願い致します。
RECOMMENDED STIFFENER MATERIAL: POLYIMIDE
RECOMMENDED BASE FILM THICKNESS: 25 MICROMETER
RECOMMENDED ADHESIVE: THERMOSETTING ADHESIVE
NOTE: PLEASE PUT APPROPRIATE AMOUNT OF ADHESIVE ON ADHEREND BECAUSE THERE IS A POSSIBILITY THAT THE EXTRA ADHESIVE CAUSES THE DEFECT IN ELECTRICAL CONTINUITY.

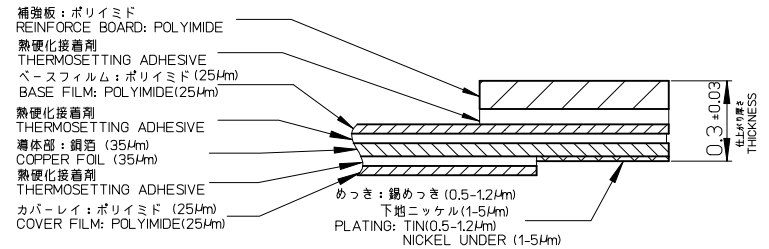

FPC構成推奨仕様
STRUCTURE OF FPC

SEE SHEET 1 OF 2 EC NO: J2014-0096 DRAWN: AISHII 2013/07/18 CHKD: KAKAHASHI 2013/07/18 APPR: YUOGAWA 2013/08/19	DESCRIPTION	GENERAL TOLERANCES (UNLESS SPECIFIED)		DIMENSION STYLE MM ONLY		SCALE ---	DESIGN UNITS METRIC	THIRD ANGLE PROJECTION	
		10 UNDER	±0.2	DRAWN BY AISHII	DATE 2012/09/03	TITLE 0.5MM FPC CONN ZIF R/A HOUSING ASSY (LOWER CONTACT)			
		10 OVER 30 UNDER	±0.25	CHECKED BY KAKAHASHI	DATE 2012/09/03	molex			
		30 OVER	±0.3	APPROVED BY KMORIKAWA	DATE 2013/04/16				
ANGULAR ±3 °		DRAFT WHERE APPLICABLE MUST REMAIN WITHIN DIMENSIONS		SEE CHART		DOCUMENT NO. SD-54132-066		SHEET NO. 2 OF 2	
THIS DRAWING CONTAINS INFORMATION THAT IS PROPRIETARY TO MOLEX INCORPORATED AND SHOULD NOT BE USED WITHOUT WRITTEN PERMISSION									

NOTES

- 54132-**22のアクチュエータはハウジング内に押し下げた状態とする。
詳細寸法については図面SD-54132-066をご参照下さい。
ACTUATOR OF PART NO. 54132-**22 SHOULD BE LOCKED.
BE DETAILED DIMENSIONS, SEE SD-54132-066.
- 梱包数量：1500個/リール
NUMBER OF CONNECTORS : 1500 PCS/REEL
- リードテープ長さ
LEAD TAPE LENGTH
- カバーテープの剥離強度については、IEC60286-3に準拠
COVER TAPE PEEL FORCE IS DEFINED BY IEC 60286-3.
- 材料
MATERIAL
キャリアテープ：ポリスチレン (PS)
CARRIER TAPE: POLYSTYRENE (PS)
トップテープ：PS
TOP TAPE : PS
リール：ポリスチレン
REEL: POLYSTYLENE
- ELV及びRoHS適合品
ELV AND RoHS COMPLIANT

引き出し方向
PULL OUT
DIRECTION

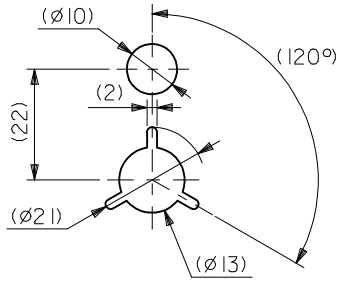
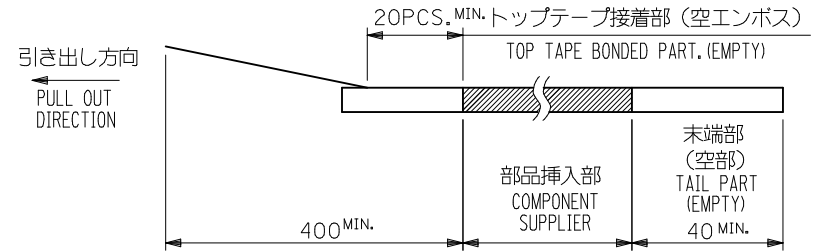
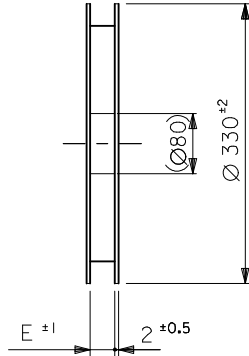
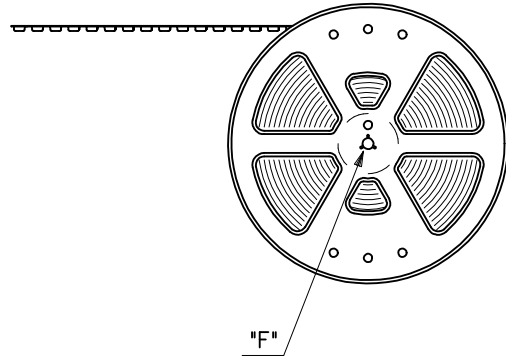

DETAIL "F"

RELEASED EC NO: J2013-1133 DRW: AISHII 2012/09/03 CHK: KTAKAHASHI 2012/09/03 APPR: KMORIKAWA 2013/04/16	DESCRIPTION GENERAL TOLERANCES (UNLESS SPECIFIED) 10 UNDER ± --- 10 OVER 30 UNDER ± --- 30 OVER ± --- ANGULAR ± --- ° DRAFT WHERE APPLICABLE MUST REMAIN WITHIN DIMENSIONS	DIMENSION STYLE MM ONLY	SCALE ---	DESIGN UNITS METRIC	THIRD ANGLE PROJECTION		
		DRAWN BY AISHII	DATE 2012/09/03	TITLE EMBOSS TAPE PACKAGED FOR 0.5MM FPC CONN ZIF R/A HOUSING ASSY			
		CHECKED BY KTAKAHASHI	DATE 2012/09/03	MATERIAL NO. SEE CHART			
		APPROVED BY KMORIKAWA	DATE 2013/04/16	DOCUMENT NO. SD-54132-067	SHEET NO. 1 OF 2		

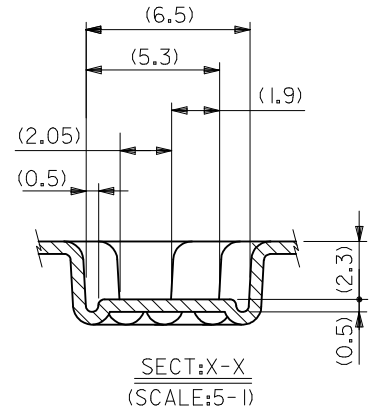
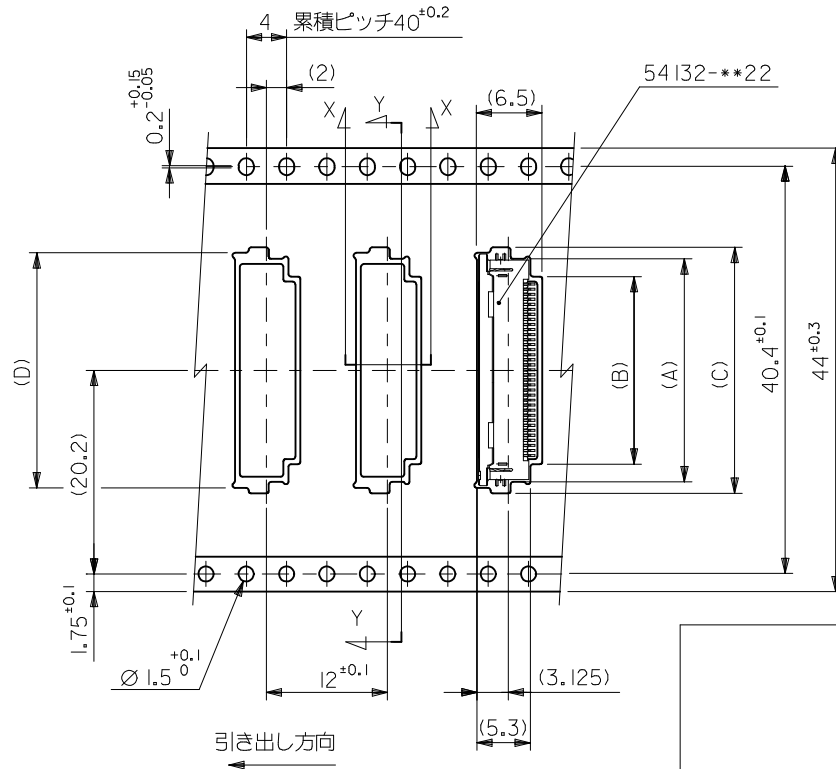
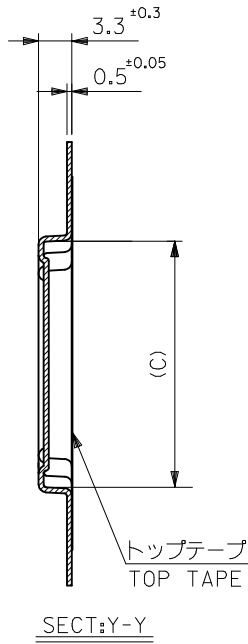

44	45.5	30.8	31.6	26.1	29.6	54132-5033	50	
		28.3	29.4	23.6	27.1	-4533	45	
		27.3	28.4	22.6	26.1	-4333	43	
		25.8	26.9	21.1	24.6	-4033	40	
		24.8	25.9	20.1	23.6	-3833	38	
		23.8	24.9	19.1	22.6	-3633	36	
		23.3	24.4	18.6	22.1	-3533	35	
		22.8	23.9	18.1	21.6	-3433	34	
		22.3	23.4	17.6	21.1	-3333	33	
		21.8	22.9	17.1	20.6	-3233	32	
20.8	21.9	16.1	19.6	54132-3033	30			
キャリアテープ幅 CARRIER TAPE WIDTH		E	D	C	B	A	製品番号 MATERIAL No.	極数 CIRCUIT

SEE SHEET 1 OF 2 EC NO: J2013-1133 DRW: AISHII 2012/09/03 CHK: KTAKAHASHI 2012/09/03 APP: KMORIKAWA 2013/04/16	DESCRIPTION REV: 0	GENERAL TOLERANCES (UNLESS SPECIFIED)		DIMENSION STYLE MM ONLY		SCALE ---	DESIGN UNITS METRIC	THIRD ANGLE PROJECTION		
		10 UNDER	± ---	DRAWN BY AISHII	DATE 2012/09/03	TITLE EMBOSS TAPE PACKAGED FOR 0.5MM FPC CONN ZIF R/A HOUSING ASSY				
		10 OVER 30 UNDER	± ---	CHECKED BY KTAKAHASHI	DATE 2012/09/03					
		30 OVER	± ---	APPROVED BY KMORIKAWA	DATE 2013/04/16					
ANGULAR ± --- °		DRAFT WHERE APPLICABLE MUST REMAIN WITHIN DIMENSIONS		SEE CHART		DOCUMENT NO. SD-54132-067		SHEET NO. 2 OF 2		
THIS DRAWING CONTAINS INFORMATION THAT IS PROPRIETARY TO MOLEX INCORPORATED AND SHOULD NOT BE USED WITHOUT WRITTEN PERMISSION										