



**HESTORE.HU**

elektronikai alkatrész áruház

**EN:** This Datasheet is presented by the manufacturer.

Please visit our website for pricing and availability at [www.hestore.hu](http://www.hestore.hu).

**■ Features**

- High Luminous LEDs
- 3mm Round Standard Directivity
- Candle Flashing Type
- Water Clear

**■ Applications**

- Toys
- Games
- Audio
- Other Lighting

**■ Absolute Maximum Rating (Ta=25°C)**

Item	Symbol	Value	Unit
Power Supply	Voltage	5.0	V
Operating Temperature	Topr	-30 ~ +85	°C
Storage Temperature	Tstg	-40~ +100	°C
Lead Soldering Temperature	Tsol	260°C/5sec	-

**■ Outline Dimension**

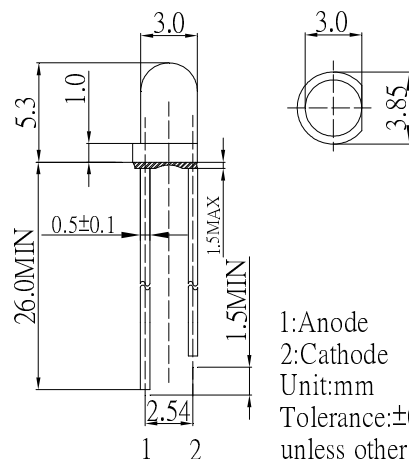

1: Anode  
2: Cathode  
Unit:mm  
Tolerance:±0.20mm  
unless otherwise noted

**■ Directivity**

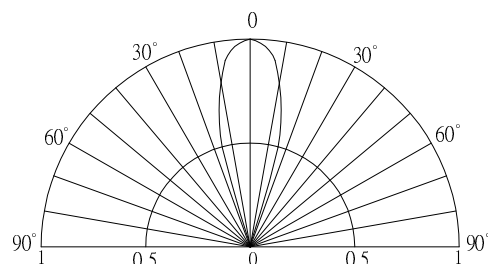

**■ Electrical -Optical Characteristics (Ta=25°C)**

Part Number	Color		V <sub>F</sub> (V)			I <sub>v</sub> (mcd)*			CCT(K)/λD(nm)*			2θ <sub>1/2</sub> (deg)
			Min.	Typ.	Max.	Typ.	Typ.	Max.	Min.	Typ.	Max.	Typ.
			I <sub>F</sub> =20mA			I <sub>F</sub> =20mA						
OS5WDK3131A	White	W	2.5	3.3	5.0	5800	7000	-	8500-18000K(X:0.27,Y:0.28)			30
OS5MDK3131A	Warm White	M	2.5	3.3	5.0	4200	5800	-	2700-3300K(X:0.45,Y:0.41)			30
OS2MDK3131A	Warm White	M	2.5	3.3	5.0	4200	5800	-	2000-2400K(X:0.51,Y:0.41)			30
OSB5SK3131A	Blue	B	2.5	3.3	5.0	1560	2500	-	465	470	475	30
OSG5DK3131A	Pure Green	PG	2.5	3.3	5.0	12000	14000	-	520	525	530	30
OSY5MK3131A	Yellow	Y	2.5	3.3	5.0	4200	5800	-	585	590	595	30
OSR5MK3131A	Red	R	2.5	3.3	5.0	4200	5800	-	620	625	630	30

\*1 Tolerance of measurements of Chromaticity coordinates is ±10%

\*2 Tolerance of measurements of Dominant wavelength is ±1nm

\*3 Tolerance of measurements of Luminous intensity is ±15%

\*4 Tolerance of measurements of Forward voltage is ±0.1V

\*5 Tolerance of measurements of Frequency is ±20%