



HESTORE.HU

elektronikai alkatrész áruház

EN: This Datasheet is presented by the manufacturer.

Please visit our website for pricing and availability at www.hestore.hu.

Rayson

Bluetooth® Module

Class2 BC04-ext Module

BTM-112

Features

- The module is a Max.4dBm(Class2) module.
- Bluetooth standard Ver. 2.0 + EDR conformity.
- Internal 1.8V regulator
- Low current consumption :
Hold,Sniff,Park,Deep sleep Mode
- 3.0v to 3.6v operation
- Support for up to seven slaves :
SCO links,ACL links,Piconet<7>
- Interface: USB,UART&PCM(for voice CODEC)
- SPP firmware with AT command sets
- Small outline. 25 x 14.5 x 2.2 mm

Applications

- Notebook PC
- PDA
- Digital camera & printer
- GPS,POS, Barcode Reader
- Domestic and industrial applications

Outline



General Electrical Specification

Parameter	Description	Min.	Typ.	Max.	Units
Carrier Frequency		2.402		2.480	GHz
Operating Voltage (VDD)		3.00	3.30	3.60	V
RF Output Power	Measured in 50 ohm	-6	0	4	dBm
RX Sensitivity			-83	-70	dBm
Load Impedance	No abnormal Oscillation			5:1	-
Input Low Voltage	RESET,UART,GPIO,PCM	-0.30	-	0.80	V
Input High Voltage	RESET,UART,GPIO,PCM	0.70VDD	-	VDD+0.30	V
Output Low Voltage	UART,GPIO,PCM	-	-	0.40	V
Output High Voltage	UART,GPIO,PCM	VDD-0.40	-	-	V
Average Current Consumption	SCO connection HV1		46	-	mA
Peak Current	Tx burst +4dBm		-	80	mA

Block Diagram

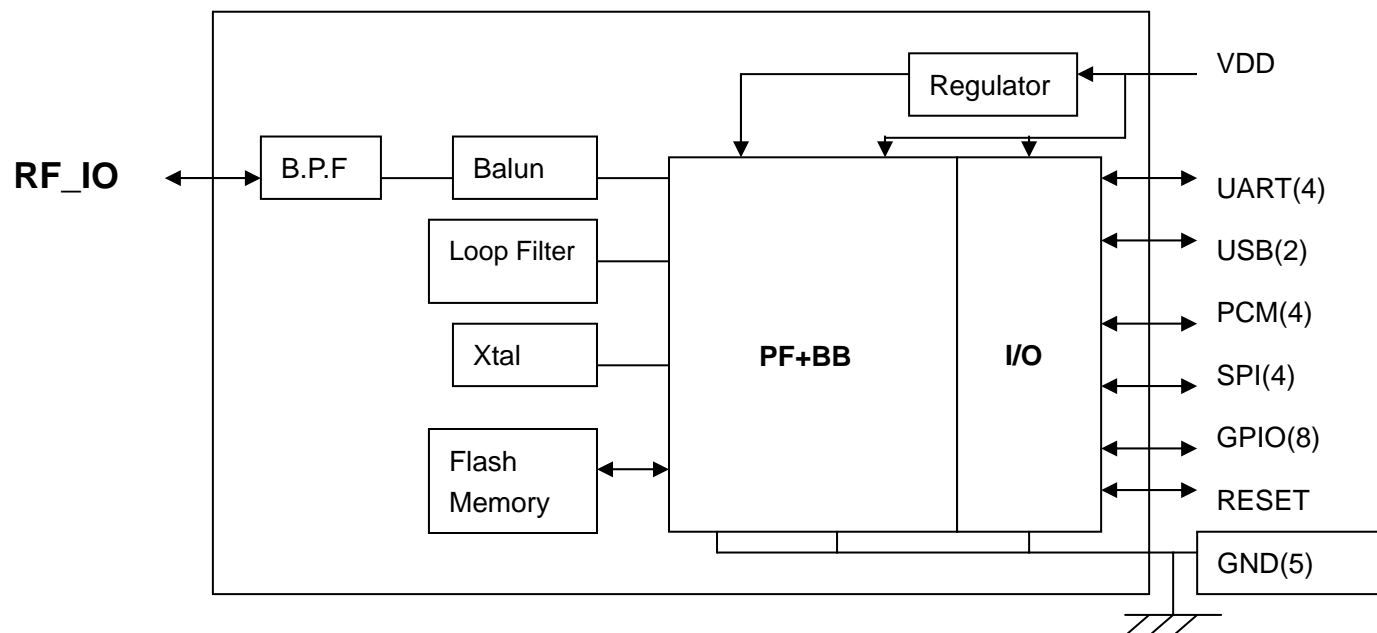

BTM-11x Specification

Radio Characteristics – Basic Data Rate

Radio Characteristics, VDD = 3.3V Temperature =+20°C						
	Frequency (GHz)	Min	Typ	Max	Bluetooth Specification	Unit
Sensitivity at 0.1% BER	2.402	-	-83	-82	≤ - 70	dBm
	2.441	-	-83	-82		dBm
	2.480	-	-83	-82		dBm
Maximum received signal at 0.1% BER	2.402	-	-6	0	≥ - 20	dBm
	2.441	-	-6	0		dBm
	2.480	-	-6	0		dBm
RF transmit power ⁽¹⁾	2.402	-	+2	-	-6 to +4 ⁽²⁾	dBm
	2.441	-	+2	-		dBm
	2.480	-	+2	-		dBm
Initial carrier frequency tolerance	2.402	-	12	20	±75	kHz
	2.441	-	10	20		kHz
	2.480	-	9	20		kHz
20dBm bandwidth for modulated carrier	2.402	-	879	1000	≤ 1000	kHz
	2.441	-	816	1000		kHz
	2.480	-	819	1000		kHz
Drift (single slot packet)	2.402	-	-	20	≤25	kHz
	2.441	-	-	20		kHz
	2.480	-	-	20		kHz
Drift (five slot packet)	2.402	-	-	20	≤40	kHz
	2.441	-	-	20		kHz
	2.480	-	-	20		kHz
Drift Rate	2.402	-	-	15	20	kHz/50µs
	2.441	-	-	15		kHz/50µs
	2.480	-	-	15		kHz/50µs
RF power control range		16	35	-	≥16	dB
RF power range control resolution		-	1.8	-	-	dB
$\Delta f1^{avg}$ "Maximum Modulation"	2.402	145	165	175	140< $\Delta f1^{avg}$ <175	kHz
	2.441	145	165	175		kHz
	2.480	145	165	175		kHz
$\Delta f2^{maz}$ "Minimum Modulation"	2.402	115	150	-	115	kHz
	2.441	115	150	-		kHz
	2.480	115	150	-		kHz
C/I co-channel		-	10	11	≤ 11	dB
Adjacent channel selectivity C/I F=F ₀ +1 MHz ⁽³⁾⁽⁵⁾		-	-4	0	≤ 0	dB
Adjacent channel selectivity C/I F=F ₀ - 1MHz ⁽³⁾⁽⁵⁾		-	-4	0	≤ 0	dB
Adjacent channel selectivity C/I F=F ₀ +2 MHz ⁽³⁾⁽⁵⁾		-	-35	-30	≤ - 30	dB
Adjacent channel selectivity C/I F=F ₀ - 2MHz ⁽³⁾⁽⁵⁾		-	-21	-20	≤ - 20	dB
Adjacent channel selectivity C/I F>=F ₀ +3 MHz ⁽³⁾⁽⁵⁾		-	-45	-	≤ - 40	dB
Adjacent channel selectivity C/I F<=F ₀ -5 MHz ⁽³⁾⁽⁵⁾		-	-45	-	≤ - 40	dB
Adjacent channel selectivity C/I F=F _{image} ⁽³⁾⁽⁵⁾		-	-18	-9	≤ - 9	dB
Adjacent channel transmit power F=F ₀ ±2MHz ⁽⁴⁾⁽⁵⁾		-	-35	-20	≤ - 20	dBc
Adjacent channel transmit power F=F ₀ ±3MHz ⁽⁴⁾⁽⁵⁾		-	-55	-40	≤ - 40	dBc

Notes:

- (1) BlueCore-External firmware maintains the transmit power to be within the Bluetooth specification v2.0 limits.
- (2) Class 2 RF transmit power range, Bluetooth specification v2.0
- (3) Up to five exceptions are allowed in v2.0 of the Bluetooth specification

(4) Up to three exceptions are allowed in v2.0 of the Bluetooth specification

(5) Measured at $F_0 = 2441\text{MHz}$

Radio Characteristics – Enhanced Data Rate

Transmitter , VDD = 3.3V Temperature =+20°C						
	Frequency (GHz)	Min.	Typ.	Max.	Bluetooth Specification	Unit
Maximum RF transmit power	2.402	-6	0	+2	-6 to +20	dBm
	2.441	-6	0	+2		dBm
	2.480	-6	0	+2		dBm
Relative transmit power		-	-1.5	-	-4 to +1	dB
$\pi/4$ DQPSK Maximum carrier frequency stability w_0		-	2	-	$\leq \pm 10$ for all blocks	kHz
$\pi/4$ DQPSK Maximum carrier frequency stability w_i		-	6	-	$\leq \pm 75$ for all packets	kHz
$\pi/4$ DQPSK Maximum carrier frequency stability $ w_0 + w_i $		-	8	-	$\leq \pm 75$ for all blocks	kHz
8 DPSK Maximum carrier frequency stability w_0		-	2	-	$\leq \pm 10$ for all blocks	kHz
8 DPSK Maximum carrier frequency stability w_i		-	6	-	$\leq \pm 75$ for all packets	kHz
8 DPSK Maximum carrier frequency stability $ w_0 + w_i $		-	8	-	$\leq \pm 75$ for all blocks	kHz
$\pi/4$ DQPSK Modulation Accuracy	RMS DVEM	-	7	-	≤ 20	%
	99% DEVM	-	13	-	≤ 30	%
	Peak DEVM	-	19	-	≤ 35	%
8 DPSK Modulation Accuracy	RMS DVEM	-	7	-	≤ 13	%
	99% DEVM	-	13	-	≤ 20	%
	Peak DEVM	-	17	-	≤ 25	%
In-band spurious emissions	$F > F_0 + 3\text{ MHz}$	-	<-50	-	≤ -40	dBm
	$F < F_0 - 3\text{ MHz}$	-	<-50	-	≤ -40	dBm
	$F = F_0 - 3\text{ MHz}$	-	-46	-	≤ -40	dBm
	$F = F_0 - 2\text{ MHz}$	-	-34	-	≤ -20	dBm
	$F = F_0 - 1\text{ MHz}$	-	-35	-	≤ -26	dBm
	$F = F_0 + 1\text{ MHz}$	-	-35	-	≤ -26	dBm
	$F = F_0 + 2\text{ MHz}$	-	-31	-	≤ -20	dBm
	$F = F_0 + 3\text{ MHz}$	-	-33	-	≤ -40	dBm
EDR Differential Phase Encoding			No Errors		≥ 99	%
Receiver , VDD = 3.3V Temperature =+20°C						
	Modulation	Min.	Typ.	Max.	Bluetooth Specification	Unit
Sensitivity at 0.1% BER	$\pi/4$ DQPSK	-	-82	-	≤ -70	dBm
	8 DPSK	-	-76	-	≤ -70	dBm
Maximum received signal level at 0.1% BER	$\pi/4$ DQPSK	-	-8	-	≥ -20	dBm
	8 DPSK	-	-10	-	≥ -20	dBm
C/I co-channel at 0.1% BER	$\pi/4$ DQPSK	-	10	-	$\leq +13$	dB
	8 DPSK	-	19	-	$\leq +21$	dB
Adjacent channel selectivity C/I $F = F_0 + 1\text{ MHz}$	$\pi/4$ DQPSK	-	-10	-	≤ 0	dB
	8 DPSK	-	-5	-	$\leq +5$	dB
Adjacent channel selectivity C/I $F = F_0 - 1\text{ MHz}$	$\pi/4$ DQPSK	-	-11	-	≤ 0	dB
	8 DPSK	-	-5	-	$\leq +5$	dB

Adjacent channel selectivity C/I F=F ₀ +2 MHz	$\pi/4$ DQPSK	-	-40	-	≤ -30	dB
	8 DPSK	-	-40	-	≤ -25	dB
Adjacent channel selectivity C/I F=F ₀ -2 MHz	$\pi/4$ DQPSK	-	-23	-	≤ -20	dB
	8 DPSK	-	-20	-	≤ -13	dB
Adjacent channel selectivity C/I F=F ₀ +3 MHz	$\pi/4$ DQPSK	-	-45	-	≤ -40	dB
	8 DPSK	-	-45	-	≤ -33	dB
Adjacent channel selectivity C/I F=F ₀ -5 MHz	$\pi/4$ DQPSK	-	-45	-	≤ -40	dB
	8 DPSK	-	-45	-	≤ -33	dB
F ₀ = 2405, 2441, 2477 MHz						
Adjacent channel selectivity C/I F=F _{image}	$\pi/4$ DQPSK		-20		≤ -7	dB
	8 DPSK		-15		≤ 0	dB

SPP AT Command sets

A (Establish connection)	When it's in master mode. This command establish a connection. When it's in slave mode, the command will be rejected.	
	<i>Modifiers</i>	<i>Description</i>
	A	Connect to a Bluetooth device (It's only available when "ATD=XXXXXXXXXXXX" assigned)
	A1~A8	Connect to a Bluetooth neighborhood device 1~8 (ATF? Result)
B (Display local BD address)	This command display the local device BD address	
	<i>Modifiers</i>	<i>Description</i>
	B?	Inquire the Local BD address
D (Set Remote BD address)	For security purpose, We can specifies the unique remote device can be connected. In master role, it automatically inquire and search the slave even the slave is undiscoverable. In slave role, the command should be as a filter condition to accept the master's inquiry.	
	<i>Modifiers</i>	<i>Description</i>
	D=XXXXXXXXXXXX	"xxxx-xx-xxxxxx" is 12 digit hex symbol
	D0 (Default)	Clear Remote BD address setting, inquire any slave in master mode or accept any master in slave mode.
	D?	Inquire the Remote BD address setting
E (Local Echo)	This command specifies whether the device should echo characters received from the UART back to the DTE/DCE.	
	<i>Modifiers</i>	<i>Description</i>
	E0	Command characters received from the UART are not echoed back to the DTE/DCE.
	E1 (Default)	Command characters received from the UART are echoed back to the DTE/DCE.
	E?	Inquire the current setting
F (Find Bluetooth device)	This command is used to find any bluetooth device in neighborhood within 60 seconds timeout. If any device is found, its name and address will be listed. The search ends with a message "Inquiry ends, xx device(s) found." This command is available only when the adaptor is in the master role.	
	<i>Modifiers</i>	<i>Description</i>
	F?	Inquire scan Bluetooth neighborhood devices.

H (Discoverable Control)	This command specifies whether the device could be discovered by remote master device.	
	<i>Modifiers</i>	<i>Description</i>
	H0	The device enters undiscoverable mode. If a pair have been made, the original connection could be connected again. Other remote master device can not discovery this device.
	H1 (Default)	The device enters discoverable mode.
	H?	Inquire the current setting
I (Information)	This command is used to Inquiry the F/W version	
	<i>Modifiers</i>	<i>Description</i>
	I?	Inquire the version Codes
K (Stop setting) bits	This command is used to specify one or two stop bits of COM port	
	<i>Modifiers</i>	<i>Description</i>
	K0 (Default)	One Stop bit
	K1	Two stop bits
	K?	Inquire the current setting
L (Baud Rate Control)	This command is used to specify the baud rate of COM port	
	<i>Modifiers</i>	<i>Description</i>
	L0	4800bps
	L1	9600bps
	L2 (Default)	19200bps
	L3	38400bps
	L4	57600bps
	L5	115200bps
	L6	230.4Kbps
	L7	460.8Kbps
	L?	Inquire the current setting
M (Parity setting) bits	This command is used to specify the parity bit setting of COM port	
	<i>Modifiers</i>	<i>Description</i>
	M0 (Default)	None Parity bit.
	M1	Odd parity setting.
	M2	Even parity setting
	M?	Inquire the current setting
N (Set name) device	We can specifies the device a friendly name using 0 to 9, A to Z, a to z, space and - , which are all valid characters. Note that "firs space or -, last space or - isn' t permitted". The default name is "Serial Adaptor"	
	<i>Modifiers</i>	<i>Description</i>
	N=xxxxx	"xxxxx" is a character string, maxima length is 16
	D?	Inquire the device name
O (Auto connect)	When it' s in master mode .The command is used to enable/disable auto-connection feature. When it' s in slave mode, the command will be rejected.	
	<i>Modifiers</i>	<i>Description</i>
	O0	Automatically connecting to a device which is assigned in "ATD" or

setting)	(Default)	any available device if “ATD” was not assigned.
	O1	Disable auto-connection feature, user should manually use “ATA” command to connect a remote device.
	O?	Inquire the current setting
P (Set PIN code)	This command specifies the PIN number. It control to off the PIN code authorization that allow to establish a connection without PIN code. Default PIN number is "1234"	
	<i>Modifiers</i>	<i>Description</i>
	P=xxxx (Default)	"xxxx" is 4~8 digit string
	P0	Turn off the PIN code authorization
	P?	Inquire the current PIN number
Q (Result Code Supression)	The command is used to determine if result Codes should be sent to the DTE/DCE. When result Codes are suppressed, the device does not generate any characters in response to the completion of a command or when an event occurs. Four Result Codes : OK,CONNECT,DISCONNECT,ERROR	
	<i>Modifiers</i>	<i>Description</i>
	Q0 (Default)	The device will send Result Codes to the DTE/DCE.
	Q1	The device will not send Result Codes to the DTE/DCE.
	Q?	Inquire the current setting
R (Set Role)	This command specifies whether the device could be master or slave device. If change the role, the adaptor will warm start and clear all paired addresses.	
	<i>Modifiers</i>	<i>Description</i>
	R0	The device as master role.
	R1 (Default)	The device as slave role.
	R?	Inquire the current setting
U (F/W upgrade)	This command will prompt “Enter DFU mode, Are you sure (y/n)?” message, then press Y to confirm the command. Then you should connect USB cable to PC and run DFU wizard. (DFU wizard please contact us www.rayson.com)	
	<i>Modifiers</i>	<i>Description</i>
	U=pass word	Pass word = RaysonUpgrade ,Go into Upgrade F/W Mode
Z (Application setting)	Restore different application setting and warm start.	
	<i>Modifiers</i>	<i>Description</i>
	Z0	Restore factory default setting (19200bps, slave ….)
	Z?	Inquire the current setting

The factory settings of UART are as follows:

- Baud rate: 19200 bps
- Data bit: 8
- Parity: none
- Stop bit: 1
- Flow control: H/W or none
- Others: Please refer to AT Command Sets.

BTM-112 Pin Functions

PIN	NAME	TYPE	FUNCTION	REMARK
1	PIO(8)	Bi-directional	Programmable Input/Output line	
2	PIO(9)	Bi-directional	Programmable Input/Output line	
3	PIO(10)	Bi-directional	Programmable Input/Output line	
4	AIO0	Bi-directional	Programmable Input/Output Line	
5	AIO1	Bi-directional	Programmable Input/Output Line	
6	RESET	CMOS input	Reset if high. Input debounced so must be high for >5ms to cause a reset	
7	SPI_MISO	CMOS Output	Serial Peripheral Interface Data Output	
8	SPI_CSB	CMOS Input	Chip Select For Synchronous Serial Interface active low	
9	SPI_CLK	CMOS Input	Serial Peripheral Interface Clock	
10	SPI_MOSI	CMOS Input	Serial Peripheral Interface Data Input	
11	UART_CTS	CMOS Input	UART Clear To Send (Active Low)	
12	UART_TX	CMOS Output	UART Data Output	
13	UART_RTS	CMOS Output	UART Request To Send (Active Low)	
14	UART_RX	CMOS Input	UART Data Input	
15	PIO(11)	Bi-directional	Programmable Input/Output line	
16	3V3	Power	3.3V Power Supply Input	
17	GND	GND	Ground	
18	PCM_OUT	CMOS Output	Synchronous Data Output	
19	PCM_SYNC	Bi-directional	Synchronous Data Sync	
20	PCM_IN	CMOS Input	Synchronous Data Input	
21	PCM_CLK	Bi-directional	Synchronous Data Clock	
22	USB_DP	Bi-directional	USB Data Plus	
23	USB_DN	Bi-directional	USB Data Minus	
24	PIO(7)	Bi-directional	Programmable Input/Output line (Drive Link status led, active low).	
25	PIO(6)	Bi-directional	Programmable Input/Output line (connection status indication, active high)	
26	PIO(5)	Bi-directional	Programmable Input/Output line	
27	PIO(4)	Bi-directional	Programmable Input / Output Line (Button Input, active high)	
28	PIO(3)	Bi-directional	Programmable Input/Output Line	
29	PIO(2)	Bi-directional	Programmable Input / Output Line	
30	PIO(1)	Bi-directional	Programmable Input/Output Line	
31	PIO(0)	Bi-directional	Programmable Input / Output Line	
32	GND	GND	Ground	
33	RF_IO	Analogue	50 ohm Antenna connection	
34	GND	GND	Ground	

BTM-11x Pin out Information

PIN DETAILS VIEWED FROM TOP SIDE

1	34
PIO(8)	GND
PIO(9)	RF_IO
PIO(10)	GND
AIO(0)	PIO(0)
AIO(1)	PIO(1)
RESET	PIO(2)
SPI_MISO	PIO(3)
SPI_CSB	PIO(4)
SPI_CLK	PIO(5)
SPI_MOSI	PIO(6)
UART_CTS	PIO(7)
UART_TX	USB_DN
UART_RTS	USB_DP
UART_RX	PCM_CLK
PIO(11)	PCM_IN
3V3	PCM_SYNC
GND	PCM_OUT
17	18

MODULE PAD AND SOLDER MASK DETAILS

SOLDER MASK WINDOW 1.0mm MAX

SOLDER PAD 0.8mm

MECHANICAL DETAILS VIEWED FROM TOP/BOTTOM SIDE

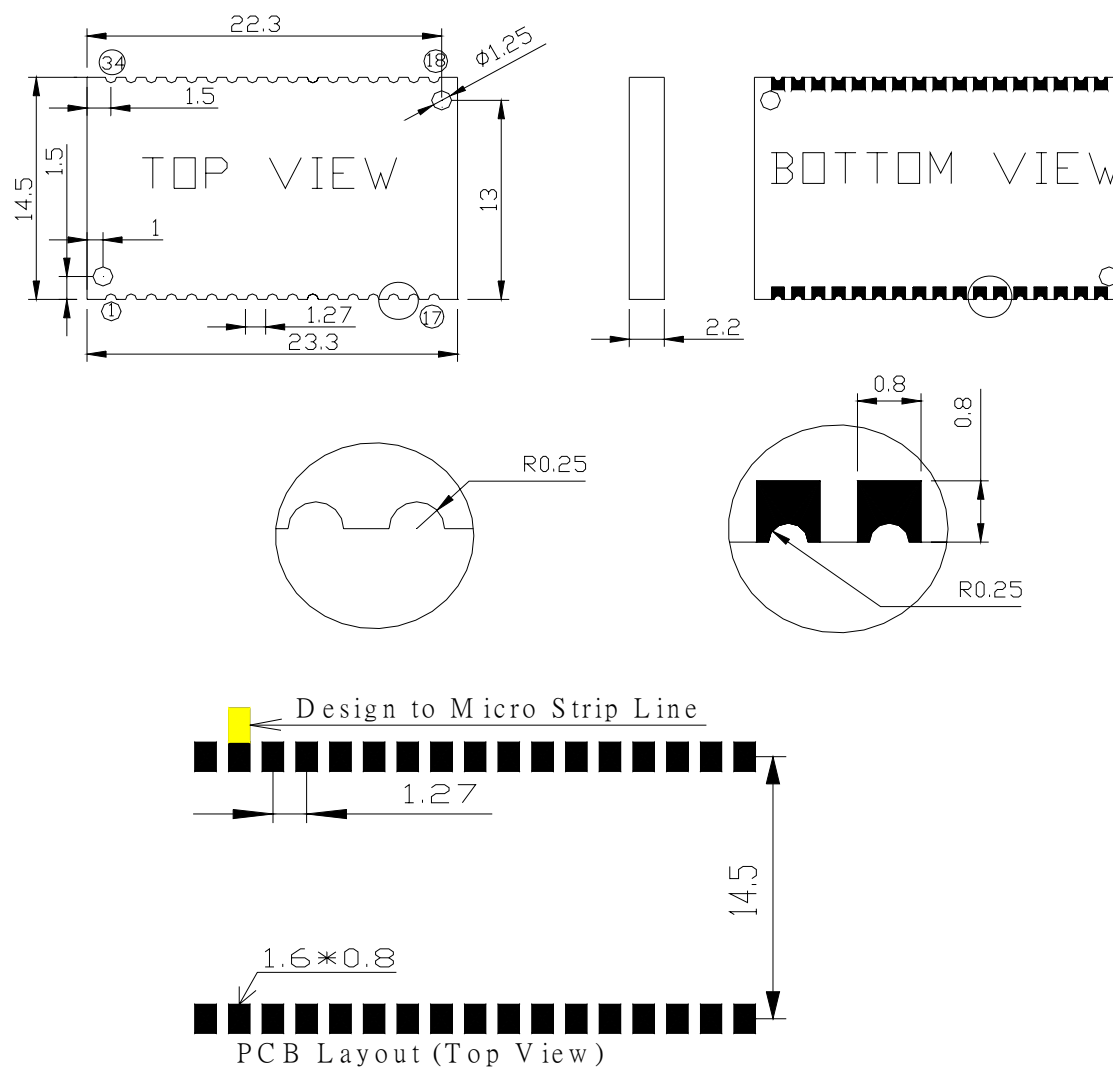

Bluetooth® Qualified Product Notice

Jan-Willem Vonk

Bluetooth Qualification Body (BQB)

TUV Rheinland Taiwan Ltd.

Applicant details	
Applicant	Rayson Technology Co., Ltd.
Address	1F, No.9, R&D Road, Science Based Industrial Park, Hsin-Chu, 300, Taiwan, R.O.C.
Person responsible	Tim Lin
Phone	+886 3 563 3666
Fax	+886 3 563 3688
E-mail	sales@mail.rayson.com

Product information	
Product name	Bluetooth Class 2 CSR BC4-ext module
Product ID	BTM-11x
Hardware Version	A5
Software Version	Unified21d
Product category	Components
Product Type	Comp-HW-Integrated
Supported profiles	None
Product Description	BC4-ext Class 2 SMD type module

Reference documents	
Core Specification	Core V2.0 + EDR
Test Case Reference List	TCRL_EDR_2005-1-BQRB1, Release date: May 1st, 2005
Program Reference Document	Version 1.0 and First Addendum
Conformance Test Specification	See Annex A

Qualified Product Notice identification	
QPN Reference No.	BQ10016907
Date of Assessment	Jun 6, 2006
Date of Listing	Jun 6, 2006