



HESTORE.HU

elektronikai alkatrész áruház

EN: This Datasheet is presented by the manufacturer.

Please visit our website for pricing and availability at www.hestore.hu.

Arm[®]-Cortex[®]-M4 32b MCU+FPU, 125 DMIPS, 128KB Flash, 32KB RAM, 9 TIMs, 1 ADC, 1 DAC, 1 LPTIM, 9 comm. interfaces

Datasheet - production data

Features

- Dynamic Efficiency Line with eBAM (enhanced Batch Acquisition Mode)
 - 1.7 V to 3.6 V power supply
 - -40 °C to 85/105/125 °C temperature range
- Core: Arm[®] 32-bit Cortex[®]-M4 CPU with FPU, Adaptive real-time accelerator (ART Accelerator™) allowing 0-wait state execution from Flash memory, frequency up to 100 MHz, memory protection unit, 125 DMIPS/1.25 DMIPS/MHz (Dhrystone 2.1), and DSP instructions
- Memories
 - Up to 128 Kbytes of Flash memory
 - 512 bytes of OTP memory
 - 32 Kbytes of SRAM
- Clock, reset and supply management
 - 1.7 V to 3.6 V application supply and I/Os
 - POR, PDR, PVD and BOR
 - 4-to-26 MHz crystal oscillator
 - Internal 16 MHz factory-trimmed RC
 - 32 kHz oscillator for RTC with calibration
 - Internal 32 kHz RC with calibration
- Power consumption
 - Run: 89 µA/MHz (peripheral off)
 - Stop (Flash in Stop mode, fast wakeup time): 40 µA Typ @ 25 °C; 49 µA max @25 °C
 - Stop (Flash in Deep power down mode, slow wakeup time): down to 6 µA @ 25 °C; 14 µA max @25 °C
 - Standby: 2.4 µA @25 °C / 1.7 V without RTC; 12 µA @85 °C @1.7 V
 - V_{BAT} supply for RTC: 1 µA @25 °C
- 1×12-bit, 2.4 MSPS ADC: up to 16 channels
- 1×12-bit D/A converter
- General-purpose DMA: 16-stream DMA controllers with FIFOs and burst support
- Up to 9 timers
 - One low-power timer (available in Stop mode)

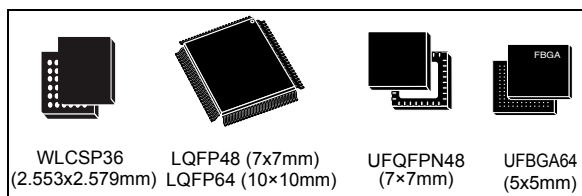

- One 16-bit advanced motor-control timer
- Three 16-bit general purpose timers
- One 32-bit timer up to 100 MHz with up to four IC/OC/PWM or pulse counter and quadrature (incremental) encoder input
- Two watchdog timers (independent window)
- SysTick timer.
- Debug mode
 - Serial wire debug (SWD) & JTAG interfaces
 - Cortex[®]-M4 Embedded Trace Macrocell™
- Up to 50 I/O ports with interrupt capability
 - Up to 45 fast I/Os up to 100 MHz
 - Up to 49 5 V-tolerant I/Os
- Up to 9 communication interfaces
 - Up to 3x I²C interfaces (SMBus/PMBus) including 1x I²C Fast-mode at 1 MHz
 - Up to 3 USARTs (2 x 12.5 Mbit/s, 1 x 6.25 Mbit/s), ISO 7816 interface, LIN, IrDA, modem control)
 - Up to 3 SPI/I2Ss (up to 50 Mbit/s SPI or I2S audio protocol)
- True random number generator
- CRC calculation unit
- 96-bit unique ID
- RTC: subsecond accuracy, hardware calendar
- All packages are ECOPACK[®]2

Table 1. Device summary

Reference	Part number
STM32F410x8	STM32F410T8, STM32F410C8, STM32F410R8
STM32F410xB	STM32F410TB, STM32F410CB, STM32F410RB

Contents

1	Introduction	11
2	Description	12
2.1	Compatibility with STM32F4 series	14
3	Functional overview	16
3.1	Arm® Cortex®-M4 with FPU core with embedded Flash and SRAM	16
3.2	Adaptive real-time memory accelerator (ART Accelerator™)	16
3.3	Batch Acquisition mode (BAM)	16
3.4	Memory protection unit	17
3.5	Embedded Flash memory	17
3.6	CRC (cyclic redundancy check) calculation unit	17
3.7	Embedded SRAM	17
3.8	Multi-AHB bus matrix	18
3.9	DMA controller (DMA)	18
3.10	Nested vectored interrupt controller (NVIC)	19
3.11	External interrupt/event controller (EXTI)	19
3.12	Clocks and startup	19
3.13	Boot modes	20
3.14	Power supply schemes	20
3.15	Power supply supervisor	21
3.15.1	Internal reset ON	21
3.15.2	Internal reset OFF	21
3.16	Voltage regulator	22
3.16.1	Internal power supply supervisor availability	22
3.17	Real-time clock (RTC) and backup registers	23
3.18	Low-power modes	23
3.19	V _{BAT} operation	24
3.20	Timers and watchdogs	24
3.20.1	Advanced-control timers (TIM1)	26
3.20.2	General-purpose timers (TIM5, TIM9 and TIM11)	26
3.20.3	Basic timer (TIM6)	26

3.20.4	Low-power timer (LPTIM1)	27
3.20.5	Independent watchdog	27
3.20.6	Window watchdog	27
3.20.7	SysTick timer	27
3.21	Inter-integrated circuit interface (I2C)	28
3.22	Universal synchronous/asynchronous receiver transmitters (USART)	28
3.23	Serial peripheral interface (SPI)	29
3.24	Inter-integrated sound (I ² S)	29
3.25	Random number generator (RNG)	29
3.26	General-purpose input/outputs (GPIOs)	30
3.27	Analog-to-digital converter (ADC)	30
3.28	Temperature sensor	30
3.29	Digital-to-analog converter (DAC)	30
3.30	Serial wire JTAG debug port (SWJ-DP)	31
3.31	Embedded Trace Macrocell™	31
4	Pinouts and pin description	32
5	Memory mapping	44
6	Electrical characteristics	48
6.1	Parameter conditions	48
6.1.1	Minimum and maximum values	48
6.1.2	Typical values	48
6.1.3	Typical curves	48
6.1.4	Loading capacitor	48
6.1.5	Pin input voltage	49
6.1.6	Power supply scheme	50
6.1.7	Current consumption measurement	51
6.2	Absolute maximum ratings	51
6.3	Operating conditions	53
6.3.1	General operating conditions	53
6.3.2	VCAP_1 external capacitor	56
6.3.3	Operating conditions at power-up/power-down (regulator ON)	56
6.3.4	Operating conditions at power-up / power-down (regulator OFF)	56
6.3.5	Embedded reset and power control block characteristics	57

6.3.6	Supply current characteristics	58
6.3.7	Wakeup time from low-power modes	77
6.3.8	External clock source characteristics	78
6.3.9	Internal clock source characteristics	83
6.3.10	PLL characteristics	84
6.3.11	PLL spread spectrum clock generation (SSCG) characteristics	86
6.3.12	Memory characteristics	87
6.3.13	EMC characteristics	89
6.3.14	Absolute maximum ratings (electrical sensitivity)	91
6.3.15	I/O current injection characteristics	91
6.3.16	I/O port characteristics	92
6.3.17	NRST pin characteristics	97
6.3.18	TIM timer characteristics	98
6.3.19	Communications interfaces	99
6.3.20	12-bit ADC characteristics	109
6.3.21	Temperature sensor characteristics	114
6.3.22	V _{BAT} monitoring characteristics	115
6.3.23	Embedded reference voltage	115
6.3.24	DAC electrical characteristics	116
6.3.25	RTC characteristics	118
7	Package information	119
7.1	WLCSP36 package information	119
7.2	UFQFPN48 package information	122
7.3	LQFP48 package information	125
7.4	LQFP64 package information	129
7.5	UFBGA64 package information	132
7.6	Thermal characteristics	135
7.6.1	Reference document	135
8	Part numbering	136
Appendix A	Recommendations when using the internal reset OFF	137
A.1	Operating conditions	137
Appendix B	Application block diagrams	138
B.1	Sensor Hub application example	138

B.2 Batch Acquisition Mode (BAM) example 139

Revision history 140

List of tables

Table 1.	Device summary	1
Table 2.	STM32F410x8/B features and peripheral counts	13
Table 3.	Embedded bootloader interfaces	20
Table 4.	Regulator ON/OFF and internal power supply supervisor availability.	22
Table 5.	Timer feature comparison.	25
Table 6.	Comparison of I2C analog and digital filters.	28
Table 7.	USART feature comparison	29
Table 8.	Legend/abbreviations used in the pinout table	34
Table 9.	STM32F410x8/B pin definitions	35
Table 10.	Alternate function mapping.	41
Table 11.	STM32F410x8/B register boundary addresses	45
Table 12.	Voltage characteristics	51
Table 13.	Current characteristics	52
Table 14.	Thermal characteristics.	52
Table 15.	General operating conditions	53
Table 16.	Features depending on the operating power supply range	55
Table 17.	VCAP_1 operating conditions.	56
Table 18.	Operating conditions at power-up / power-down (regulator ON)	56
Table 19.	Operating conditions at power-up / power-down (regulator OFF).	56
Table 20.	Embedded reset and power control block characteristics.	57
Table 21.	Typical and maximum current consumption, code with data processing (ART accelerator disabled) running from SRAM - $V_{DD} = 1.7\text{ V}$	59
Table 22.	Typical and maximum current consumption, code with data processing (ART accelerator disabled) running from SRAM - $V_{DD} = 3.6\text{ V}$	60
Table 23.	Typical and maximum current consumption in run mode, code with data processing (ART accelerator enabled except prefetch) running from Flash memory- $V_{DD} = 1.7\text{ V}$	61
Table 24.	Typical and maximum current consumption in run mode, code with data processing (ART accelerator enabled except prefetch) running from Flash memory - $V_{DD} = 3.6\text{ V}$	62
Table 25.	Typical and maximum current consumption in run mode, code with data processing (ART accelerator disabled) running from Flash memory - $V_{DD} = 3.6\text{ V}$	63
Table 26.	Typical and maximum current consumption in run mode, code with data processing (ART accelerator disabled) running from Flash memory - $V_{DD} = 1.7\text{ V}$	64
Table 27.	Typical and maximum current consumption in run mode, code with data processing (ART accelerator enabled with prefetch) running from Flash memory - $V_{DD} = 3.6\text{ V}$	65
Table 28.	Typical and maximum current consumption in Sleep mode - $V_{DD} = 3.6\text{ V}$	66
Table 29.	Typical and maximum current consumption in Sleep mode - $V_{DD} = 1.7\text{ V}$	68
Table 30.	Typical and maximum current consumptions in Stop mode - $V_{DD} = 1.7\text{ V}$	70
Table 31.	Typical and maximum current consumption in Stop mode - $V_{DD} = 3.6\text{ V}$	70
Table 32.	Typical and maximum current consumption in Standby mode - $V_{DD} = 1.7\text{ V}$	70
Table 33.	Typical and maximum current consumption in Standby mode - $V_{DD} = 3.6\text{ V}$	71
Table 34.	Typical and maximum current consumptions in V_{BAT} mode (LSE and RTC ON, LSE low- drive mode)	71
Table 35.	Switching output I/O current consumption	74
Table 36.	Peripheral current consumption	75
Table 37.	Low-power mode wakeup timings	78
Table 38.	High-speed external user clock characteristics.	79
Table 39.	Low-speed external user clock characteristics	79
Table 40.	HSE 4-26 MHz oscillator characteristics.	81

Table 41.	LSE oscillator characteristics ($f_{LSE} = 32.768$ kHz)	82
Table 42.	HSI oscillator characteristics	83
Table 43.	LSI oscillator characteristics	84
Table 44.	Main PLL characteristics	84
Table 45.	SSCG parameter constraints	86
Table 46.	Flash memory characteristics	87
Table 47.	Flash memory programming	88
Table 48.	Flash memory programming with V_{PP} voltage	88
Table 49.	Flash memory endurance and data retention	89
Table 50.	EMS characteristics	89
Table 51.	EMI characteristics for LQFP64	90
Table 52.	ESD absolute maximum ratings	91
Table 53.	Electrical sensitivities	91
Table 54.	I/O current injection susceptibility	92
Table 55.	I/O static characteristics	92
Table 56.	Output voltage characteristics	95
Table 57.	I/O AC characteristics	95
Table 58.	NRST pin characteristics	97
Table 59.	TIMx characteristics	98
Table 60.	I ² C characteristics	99
Table 61.	SCL frequency ($f_{PCLK1} = 50$ MHz, $V_{DD} = V_{DD_I2C} = 3.3$ V)	100
Table 62.	SCL frequency ($f_{PCLK1} = 42$ MHz, $V_{DD} = V_{DD_I2C} = 3.3$ V)	101
Table 63.	FMPI ² C characteristics	102
Table 64.	SPI dynamic characteristics	104
Table 65.	I ² S dynamic characteristics	107
Table 66.	ADC characteristics	109
Table 67.	ADC accuracy at $f_{ADC} = 18$ MHz	110
Table 68.	ADC accuracy at $f_{ADC} = 30$ MHz	111
Table 69.	ADC accuracy at $f_{ADC} = 36$ MHz	111
Table 70.	ADC dynamic accuracy at $f_{ADC} = 18$ MHz - limited test conditions	111
Table 71.	ADC dynamic accuracy at $f_{ADC} = 36$ MHz - limited test conditions	111
Table 72.	Temperature sensor characteristics	114
Table 73.	Temperature sensor calibration values	114
Table 74.	V_{BAT} monitoring characteristics	115
Table 75.	Embedded internal reference voltage	115
Table 76.	Internal reference voltage calibration values	115
Table 77.	DAC characteristics	116
Table 78.	RTC characteristics	118
Table 79.	WLCSP36 - 36-pin, 2.553 x 2.579 mm, 0.4 mm pitch wafer level chip scale package mechanical data	120
Table 80.	WLCSP36 recommended PCB design rules (0.4 mm pitch)	121
Table 81.	UFQFPN48 - 48-lead, 7x7 mm, 0.5 mm pitch, ultra thin fine pitch quad flat package mechanical data	123
Table 82.	LQFP48 - 48-pin, 7 x 7 mm low-profile quad flat package mechanical data	126
Table 83.	LQFP64 - 64-pin, 10 x 10 mm low-profile quad flat package mechanical data	130
Table 84.	UFBGA64 – 64-ball, 5 x 5 mm, 0.5 mm pitch ultra profile fine pitch ball grid array package mechanical data	132
Table 85.	UFBGA64 recommended PCB design rules (0.5 mm pitch BGA)	133
Table 86.	Package thermal characteristics	135
Table 87.	Ordering information scheme	136
Table 88.	Limitations depending on the operating power supply range	137

Table 89. Document revision history 140

List of figures

Figure 1.	Compatible board design for LQFP64 package	14
Figure 2.	STM32F410x8/B block diagram	15
Figure 3.	Multi-AHB matrix	18
Figure 4.	Power supply supervisor interconnection with internal reset OFF	21
Figure 5.	LQFP48 pinout	32
Figure 6.	LQFP64 pinout	32
Figure 7.	UFQFPN48 pinout	33
Figure 8.	UFBGA64 pinout	33
Figure 9.	WLCSP36 pinout	34
Figure 10.	Memory map	44
Figure 11.	Pin loading conditions	48
Figure 12.	Input voltage measurement	49
Figure 13.	Power supply scheme	50
Figure 14.	Current consumption measurement scheme	51
Figure 15.	External capacitor C_{EXT}	56
Figure 16.	Typical V_{BAT} current consumption (LSE and RTC ON/LSE oscillator in “low power” mode selection)	72
Figure 17.	Typical V_{BAT} current consumption (LSE and RTC ON/LSE oscillator in “high-drive” mode selection)	72
Figure 18.	Low-power mode wakeup	77
Figure 19.	High-speed external clock source AC timing diagram	80
Figure 20.	Low-speed external clock source AC timing diagram	80
Figure 21.	Typical application with an 8 MHz crystal	81
Figure 22.	Typical application with a 32.768 kHz crystal	82
Figure 23.	ACC_{HSI} versus temperature	83
Figure 24.	ACC_{LSI} versus temperature	84
Figure 25.	PLL output clock waveforms in center spread mode	87
Figure 26.	PLL output clock waveforms in down spread mode	87
Figure 27.	FT/TC I/O input characteristics	94
Figure 28.	I/O AC characteristics definition	97
Figure 29.	Recommended NRST pin protection	98
Figure 30.	I ² C bus AC waveforms and measurement circuit	100
Figure 31.	FMPI ² C timing diagram and measurement circuit	103
Figure 32.	SPI timing diagram - slave mode and CPHA = 0	105
Figure 33.	SPI timing diagram - slave mode and CPHA = 1 ⁽¹⁾	106
Figure 34.	SPI timing diagram - master mode ⁽¹⁾	106
Figure 35.	I ² S slave timing diagram (Philips protocol) ⁽¹⁾	108
Figure 36.	I ² S master timing diagram (Philips protocol) ⁽¹⁾	108
Figure 37.	ADC accuracy characteristics	112
Figure 38.	Typical connection diagram using the ADC	113
Figure 39.	Power supply and reference decoupling	114
Figure 40.	12-bit buffered/non-buffered DAC	118
Figure 41.	WLCSP36 - 36-pin, 2.553 x 2.579 mm, 0.4 mm pitch wafer level chip scale package outline	119
Figure 42.	WLCSP36 - 36-pin, 2.553 x 2.579 mm, 0.4 mm pitch wafer level chip scale package recommended footprint	120
Figure 43.	WLCSP36 marking example (package top view)	121
Figure 44.	UFQFPN48 - 48-lead, 7x7 mm, 0.5 mm pitch, ultra thin fine pitch quad flat	

	package outline	122
Figure 45.	UFQFPN48 recommended footprint	123
Figure 46.	UFQFPN48 marking example (package top view)	124
Figure 47.	LQFP48 - 48-pin, 7 x 7 mm low-profile quad flat package outline	125
Figure 48.	LQFP48 - 48-pin, 7 x 7 mm low-profile quad flat package recommended footprint	127
Figure 49.	LQFP48 marking example (package top view)	128
Figure 50.	LQFP64 - 64-pin, 10 x 10 mm low-profile quad flat package outline	129
Figure 51.	LQFP64 recommended footprint	130
Figure 52.	LQFP64 marking example (package top view)	131
Figure 53.	UFBGA64 – 64-ball, 5 x 5 mm, 0.5 mm pitch ultra profile fine pitch ball grid array package outline	132
Figure 54.	UFBGA64 – 64-ball, 5 x 5 mm, 0.5 mm pitch ultra profile fine pitch ball grid array package recommended footprint	133
Figure 55.	UFBGA64 marking example (package top view)	134
Figure 56.	Sensor hub application example 1	138
Figure 57.	Sensor hub application example 2	138
Figure 58.	Batch Acquisition Mode (BAM) example	139

1 Introduction

This datasheet provides the description of the STM32F410x8/B microcontrollers.

For information on the Cortex[®]-M4 core, please refer to the Cortex[®]-M4 programming manual (PM0214) available from www.st.com.

The ARM logo, consisting of the lowercase letters 'arm' in a bold, sans-serif font.

2 Description

The STM32F410x8/B devices are based on the high-performance Arm® Cortex®-M4 32-bit RISC core operating at a frequency of up to 100 MHz. Their Cortex®-M4 core features a Floating point unit (FPU) single precision which supports all Arm single-precision data-processing instructions and data types. It also implements a full set of DSP instructions and a memory protection unit (MPU) which enhances application security.

The STM32F410x8/B belong to the STM32 Dynamic Efficiency™ product line (with products combining power efficiency, performance and integration) while adding a new innovative feature called Batch Acquisition Mode (BAM) allowing to save even more power consumption during data batching.

The STM32F410x8/B incorporate high-speed embedded memories (up to 128 Kbytes of Flash memory, 32 Kbytes of SRAM), and an extensive range of enhanced I/Os and peripherals connected to two APB buses, one AHB bus and a 32-bit multi-AHB bus matrix.

All devices offer one 12-bit ADC, one 12-bit DAC, a low-power RTC, three general-purpose 16-bit timers, one PWM timer for motor control, one general-purpose 32-bit timers and one 16-bit low-power timer. They also feature standard and advanced communication interfaces.

- Up to three I²Cs
- Three SPIs
- Three I²Ss

To achieve audio class accuracy, the I²S peripherals can be clocked via the internal PLL or via an external clock to allow synchronization.

- Three USARTs.

The STM32F410x8/B are offered in 5 packages ranging from 36 to 64 pins. The set of available peripherals depends on the selected package.

The STM32F410x8/B operate in the – 40 to +125 °C temperature range from a 1.7 (PDR OFF) to 3.6 V power supply. A comprehensive set of power-saving mode allows the design of low-power applications.

These features make the STM32F410x8/B microcontrollers suitable for a wide range of applications:

- Motor drive and application control
- Medical equipment
- Industrial applications: PLC, inverters, circuit breakers
- Printers, and scanners
- Alarm systems, video intercom, and HVAC
- Home audio appliances
- Mobile phone sensor hub

Table 2. STM32F410x8/B features and peripheral counts

Peripherals		STM32 F410 T8Y	STM32 F410 TBY	STM32 F410 C8U	STM32 F410 CBU	STM32 F410 C8T	STM32 F410 CBT	STM32 F410 R8T	STM32 F410 RBT	STM32 F410 R8I	STM32 F410 RBI	
Flash memory in Kbytes		64	128	64	128	64	128	64	128	64	128	
SRAM in Kbytes	System	32										
Timers	General-purpose	4										
	Low-power timer	1										
	Advanced-control	1										
Random number generator		1										
Communication interfaces	SPI/ I ² S	1	3									
	I ² C	2	3									
	USART	2	3									
GPIOs		23	36					50				
12-bit ADC	1											
Number of channels		4	10					16				
12-bit DAC	1											
Number of channels		1										
Maximum CPU frequency		100 MHz										
Operating voltage		1.7 to 3.6 V	1.8 to 3.6 V	1.7 to 3.6 V	1.8 to 3.6 V	1.7 to 3.6 V						
Operating temperatures		Ambient temperatures: – 40 to +85 °C / – 40 to + 105 °C / – 40 to + 125 °C										
		Junction temperature: –40 to + 130 °C										
Package		WLCSP36	UFQFPN48	LQFP48			LQFP64		UFBGA64			

2.1 Compatibility with STM32F4 series

The STM32F410x8/B are fully software and feature compatible with the STM32F4 series (STM32F42x, STM32F401, STM32F43x, STM32F41x, STM32F405 and STM32F407)

The STM32F410x8/B can be used as drop-in replacement of the other STM32F4 products but some slight changes have to be done on the PCB board.

Figure 1. Compatible board design for LQFP64 package

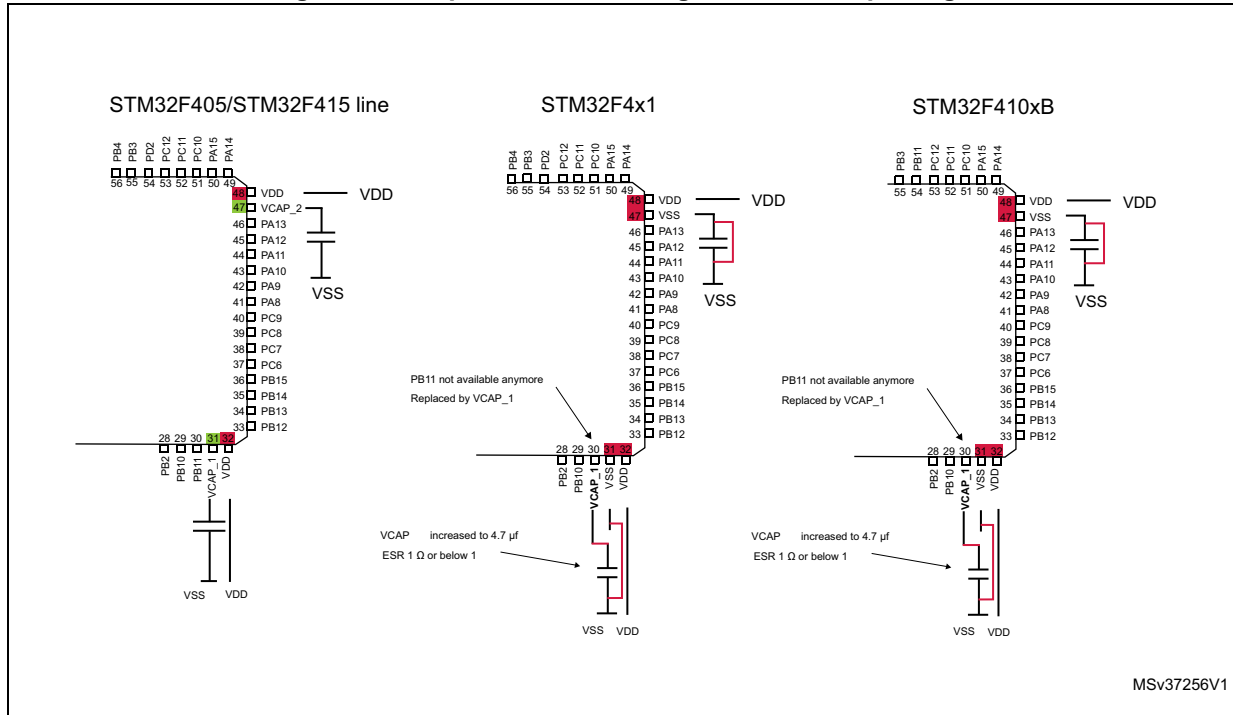

1. For STM32F410xB devices, pin 54 is bonded to PB11 instead of PD2.

Figure 2. STM32F410x8/B block diagram

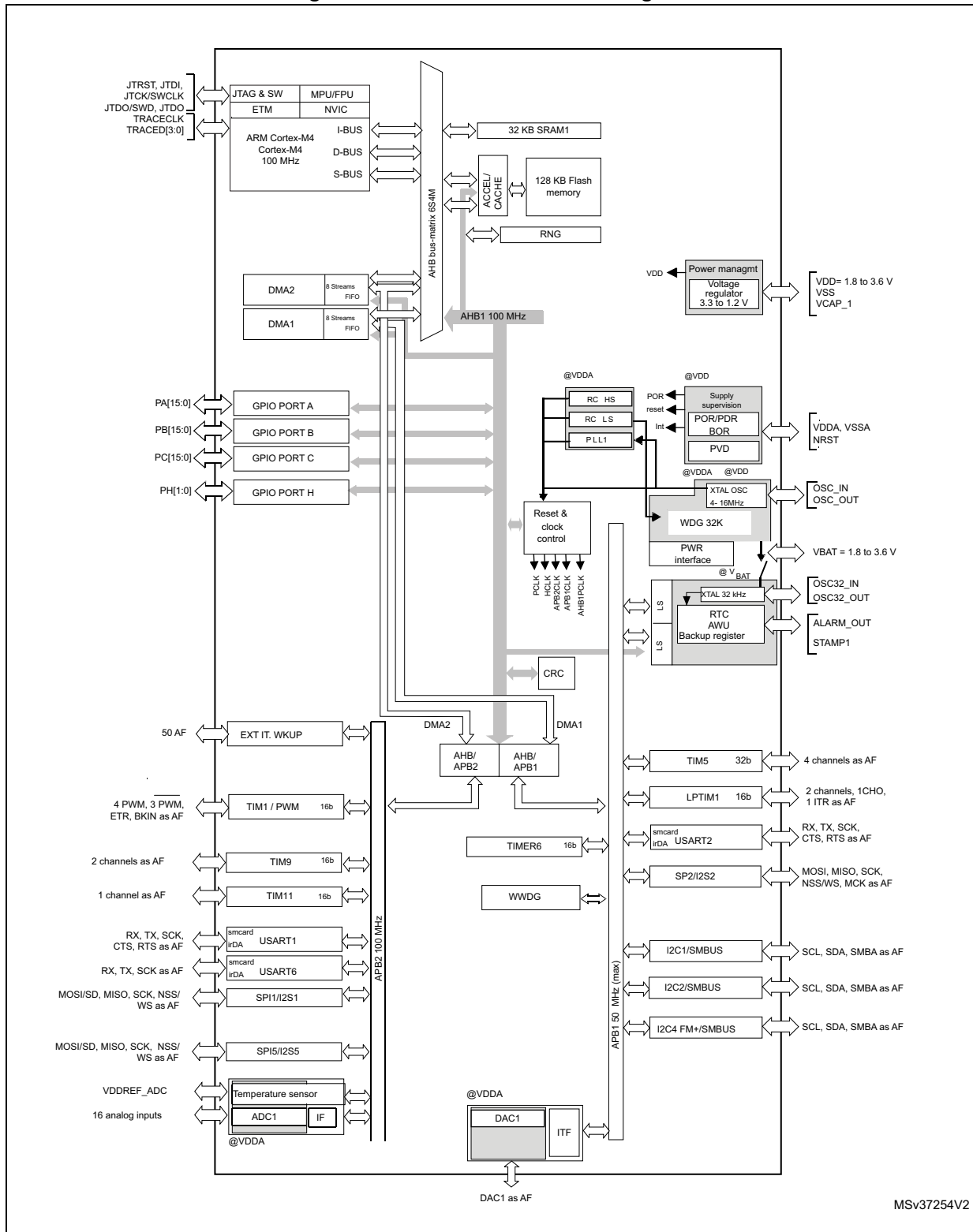

1. The timers connected to APB2 are clocked from TIMxCLK up to 100 MHz, while the timers connected to APB1 are clocked from TIMxCLK up to 100 MHz.



3 Functional overview

3.1 Arm[®] Cortex[®]-M4 with FPU core with embedded Flash and SRAM

The Arm[®] Cortex[®]-M4 with FPU processor is the latest generation of Arm processors for embedded systems. It was developed to provide a low-cost platform that meets the needs of MCU implementation, with a reduced pin count and low-power consumption, while delivering outstanding computational performance and an advanced response to interrupts.

The Arm[®] Cortex[®]-M4 with FPU 32-bit RISC processor features exceptional code-efficiency, delivering the high-performance expected from an Arm core in the memory size usually associated with 8- and 16-bit devices. The processor supports a set of DSP instructions which allow efficient signal processing and complex algorithm execution. Its single precision FPU (floating point unit) speeds up software development by using metalanguage development tools, while avoiding saturation.

The STM32F410x8/B devices are compatible with all Arm tools and software.

[Figure 2](#) shows the general block diagram of the STM32F410x8/B.

Note: Cortex[®]-M4 with FPU is binary compatible with Cortex[®]-M3.

3.2 Adaptive real-time memory accelerator (ART Accelerator[™])

The ART Accelerator[™] is a memory accelerator which is optimized for STM32 industry-standard Arm[®] Cortex[®]-M4 with FPU processors. It balances the inherent performance advantage of the Arm[®] Cortex[®]-M4 with FPU over Flash memory technologies, which normally requires the processor to wait for the Flash memory at higher frequencies.

To release the processor full 125 DMIPS performance at this frequency, the accelerator implements an instruction prefetch queue and branch cache, which increases program execution speed from the 128-bit Flash memory. Based on CoreMark benchmark, the performance achieved thanks to the ART Accelerator is equivalent to 0 wait state program execution from Flash memory at a CPU frequency up to 100 MHz.

3.3 Batch Acquisition mode (BAM)

The Batch acquisition mode allows enhanced power efficiency during data batching. It enables data acquisition through any communication peripherals directly to memory using the DMA in reduced power consumption as well as data processing while the rest of the system is in low-power mode (including the flash and ART). For example in an audio system, a smart combination of PDM audio sample acquisition and processing from the I2S directly to RAM (flash and ART[™] stopped) with the DMA using BAM followed by some very short processing from flash allows to drastically reduce the power consumption of the application. A dedicated application note (AN4515) describes how to implement the STM32F410x8/B BAM to allow the best power efficiency.

3.4 Memory protection unit

The memory protection unit (MPU) is used to manage the CPU accesses to memory to prevent one task to accidentally corrupt the memory or resources used by any other active task. This memory area is organized into up to 8 protected areas that can in turn be divided up into 8 subareas. The protection area sizes are between 32 bytes and the whole 4 gigabytes of addressable memory.

The MPU is especially helpful for applications where some critical or certified code has to be protected against the misbehavior of other tasks. It is usually managed by an RTOS (real-time operating system). If a program accesses a memory location that is prohibited by the MPU, the RTOS can detect it and take action. In an RTOS environment, the kernel can dynamically update the MPU area setting, based on the process to be executed.

The MPU is optional and can be bypassed for applications that do not need it.

3.5 Embedded Flash memory

The devices embed up to 128 Kbytes of Flash memory available for storing programs and data, plus 512 bytes of OTP memory organized in 16 blocks which can be independently locked.

To optimize the power consumption the Flash memory can also be switched off in Run or in Sleep mode (see [Section 3.18: Low-power modes](#)).

Two modes are available: Flash in Stop mode or in DeepSleep mode (trade off between power saving and startup time).

Before disabling the Flash, the code must be executed from the internal RAM.

3.6 CRC (cyclic redundancy check) calculation unit

The CRC (cyclic redundancy check) calculation unit is used to get a CRC code from a 32-bit data word and a fixed generator polynomial.

Among other applications, CRC-based techniques are used to verify data transmission or storage integrity. In the scope of the EN/IEC 60335-1 standard, they offer a means of verifying the Flash memory integrity. The CRC calculation unit helps compute a software signature during runtime, to be compared with a reference signature generated at link-time and stored at a given memory location.

3.7 Embedded SRAM

All devices embed 32 Kbytes of system SRAM which can be accessed (read/write) at CPU clock speed with 0 wait states

3.8 Multi-AHB bus matrix

The 32-bit multi-AHB bus matrix interconnects all the masters (CPU, DMAs) and the slaves (Flash memory, RAM, AHB and APB peripherals) and ensures a seamless and efficient operation even when several high-speed peripherals work simultaneously.

Figure 3. Multi-AHB matrix

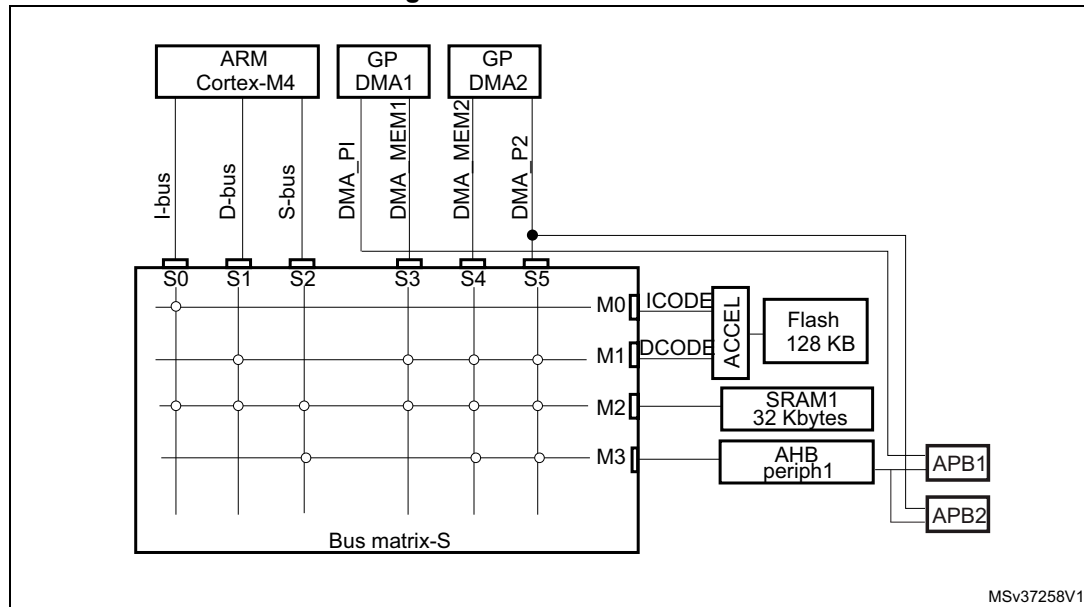

3.9 DMA controller (DMA)

The devices feature two general-purpose dual-port DMAs (DMA1 and DMA2) with 8 streams each. They are able to manage memory-to-memory, peripheral-to-memory and memory-to-peripheral transfers. They feature dedicated FIFOs for APB/AHB peripherals, support burst transfer and are designed to provide the maximum peripheral bandwidth (AHB/APB).

The two DMA controllers support circular buffer management, so that no specific code is needed when the controller reaches the end of the buffer. The two DMA controllers also have a double buffering feature, which automates the use and switching of two memory buffers without requiring any special code.

Each stream is connected to dedicated hardware DMA requests, with support for software trigger on each stream. Configuration is made by software and transfer sizes between source and destination are independent.

The DMA can be used with the main peripherals:

- SPI and I²S
- I²C
- USART
- General-purpose, basic and advanced-control timers TIMx
- ADC
- DAC.

3.10 Nested vectored interrupt controller (NVIC)

The devices embed a nested vectored interrupt controller able to manage 16 priority levels, and handle up to 62 maskable interrupt channels plus the 16 interrupt lines of the Cortex[®]-M4 with FPU.

- Closely coupled NVIC gives low-latency interrupt processing
- Interrupt entry vector table address passed directly to the core
- Allows early processing of interrupts
- Processing of late arriving, higher-priority interrupts
- Support tail chaining
- Processor state automatically saved
- Interrupt entry restored on interrupt exit with no instruction overhead

This hardware block provides flexible interrupt management features with minimum interrupt latency.

3.11 External interrupt/event controller (EXTI)

The external interrupt/event controller consists of 21 edge-detector lines used to generate interrupt/event requests. Each line can be independently configured to select the trigger event (rising edge, falling edge, both) and can be masked independently. A pending register maintains the status of the interrupt requests. The EXTI can detect an external line with a pulse width shorter than the Internal APB2 clock period. Up to 50 GPIOs can be connected to the 16 external interrupt lines.

3.12 Clocks and startup

On reset the 16 MHz internal RC oscillator is selected as the default CPU clock. The 16 MHz internal RC oscillator is factory-trimmed to offer 1% accuracy at 25 °C. The application can then select as system clock either the RC oscillator or an external 4-26 MHz clock source. This clock can be monitored for failure. If a failure is detected, the system automatically switches back to the internal RC oscillator and a software interrupt is generated (if enabled). This clock source is input to a PLL thus allowing to increase the frequency up to 100 MHz. Similarly, full interrupt management of the PLL clock entry is available when necessary (for example if an indirectly used external oscillator fails).

Several prescalers allow the configuration of the AHB bus, the high-speed APB (APB2) and the low-speed APB (APB1) domains. The maximum frequency of the AHB bus and high-speed APB domains is 100 MHz. The maximum allowed frequency of the low-speed APB domain is 50 MHz.

3.13 Boot modes

At startup, boot pins are used to select one out of three boot options:

- Boot from user Flash
- Boot from system memory
- Boot from embedded SRAM

The bootloader is located in system memory. It is used to reprogram the Flash memory by using the interfaces described in [Table 3](#).

Refer to [Table 9: STM32F410x8/B pin definitions](#)) for the GPIOs available on the selected package.

For more detailed information on the bootloader, refer to Application Note: AN2606, *STM32™ microcontroller system memory boot mode*.

Table 3. Embedded bootloader interfaces

Package	USART1	USART2	I2C1	I2C2	I2C4 FM+	SPI1	SPI3
WLCSP36	X			X	PB10/PB3	PA15/PA5 /PB4/PB5	X
UFQFPN48	PA9/PA10	PA2/PA3	PB6/PB7	X	PB14/PB15	PA4/PA5/ PA6/PA7	X
LQFP64				PB10/PB11			PB12/PB13 /PC2/PC3

3.14 Power supply schemes

- $V_{DD} = 1.7$ to 3.6 V: external power supply for I/Os with the internal supervisor (POR/PDR) disabled, provided externally through V_{DD} pins. Requires the use of an external power supply supervisor connected to the V_{DD} and PDR_ON pins.
- $V_{SSA}, V_{DDA} = 1.7$ to 3.6 V: external analog power supplies for ADC, Reset blocks, RCs and PLL. V_{DDA} and V_{SSA} must be connected to V_{DD} and V_{SS} , respectively, with decoupling technique.
- $V_{BAT} = 1.65$ to 3.6 V: power supply for RTC, external clock 32 kHz oscillator and backup registers (through power switch) when V_{DD} is not present.

3.15 Power supply supervisor

3.15.1 Internal reset ON

This feature is available for V_{DD} operating voltage range 1.8 V to 3.6 V.

The internal power supply supervisor is enabled by holding PDR_ON high.

The device has an integrated power-on reset (POR) / power-down reset (PDR) circuitry coupled with a Brownout reset (BOR) circuitry. At power-on, POR is always active, and ensures proper operation starting from 1.8 V. After the 1.8 V POR threshold level is reached, the option byte loading process starts, either to confirm or modify default thresholds, or to disable BOR permanently. Three BOR thresholds are available through option bytes.

The device remains in reset mode when V_{DD} is below a specified threshold, $V_{POR/PDR}$ or V_{BOR} , without the need for an external reset circuit.

The device also features an embedded programmable voltage detector (PVD) that monitors the V_{DD}/V_{DDA} power supply and compares it to the V_{PVD} threshold. An interrupt can be generated when V_{DD}/V_{DDA} drops below the V_{PVD} threshold and/or when V_{DD}/V_{DDA} is higher than the V_{PVD} threshold. The interrupt service routine can then generate a warning message and/or put the MCU into a safe state. The PVD is enabled by software.

3.15.2 Internal reset OFF

This feature is available on WLCSP36 package only. The internal power-on reset (POR) / power-down reset (PDR) circuitry is disabled by setting the PDR_ON pin to low.

An external power supply supervisor should monitor V_{DD} and should set the device in reset mode when V_{DD} is below 1.7 V. NRST should be connected to this external power supply supervisor. Refer to [Figure 4: Power supply supervisor interconnection with internal reset OFF](#).

Figure 4. Power supply supervisor interconnection with internal reset OFF⁽¹⁾

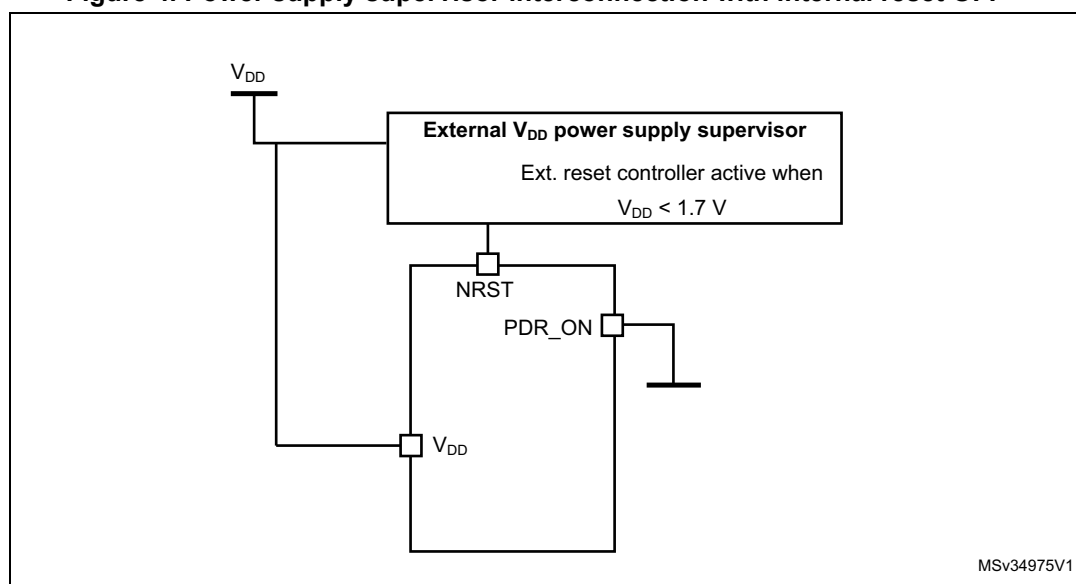

1. The PRD_ON pin is available on WLCSP36 package only.

A comprehensive set of power-saving mode allows to design low-power applications.

When the internal reset is OFF, the following integrated features are no longer supported:

- The integrated power-on reset (POR) / power-down reset (PDR) circuitry is disabled.
- The brownout reset (BOR) circuitry must be disabled.
- The embedded programmable voltage detector (PVD) is disabled.
- V_{BAT} functionality is no more available and VBAT pin should be connected to V_{DD} .

3.16 Voltage regulator

The regulator has three operating modes:

- Main regulator mode (MR)
- Low power regulator (LPR)
- Power-down

The three power modes configured by software:

- MR is used in the nominal regulation mode (With different voltage scaling in Run)
In Main regulator mode (MR mode), different voltage scaling are provided to reach the best compromise between maximum frequency and dynamic power consumption.
- LPR is used in the Stop modes
The LP regulator mode is configured by software when entering Stop mode.
- Power-down is used in Standby mode.
The Power-down mode is activated only when entering in Standby mode. The regulator output is in high impedance and the kernel circuitry is powered down, inducing zero consumption. The contents of the registers and SRAM are lost.

An external ceramic capacitor should be connected to the V_{CAP_1} pin.

3.16.1 Internal power supply supervisor availability

Table 4. Regulator ON/OFF and internal power supply supervisor availability

Package	Power supply supervisor ON	Power supply supervisor OFF
UFQFPN48	Yes	No
WLCSP36	Yes PDR_ON set to VDD	Yes PDR_ON set to $V_{SS}^{(1)}$
LQFP64	Yes	No

1. An external power supervisor must be used (refer to [Section 3.15.2: Internal reset OFF](#)).

3.17 Real-time clock (RTC) and backup registers

The backup domain includes:

- The real-time clock (RTC)
- 20 backup registers

The real-time clock (RTC) is an independent BCD timer/counter. Dedicated registers contain the second, minute, hour (in 12/24 hour), week day, date, month, year, in BCD (binary-coded decimal) format. Correction for 28, 29 (leap year), 30, and 31 day of the month are performed automatically. The RTC features a reference clock detection, a more precise second source clock (50 or 60 Hz) can be used to enhance the calendar precision. The RTC provides a programmable alarm and programmable periodic interrupts with wakeup from Stop and Standby modes. The sub-seconds value is also available in binary format.

It is clocked by a 32.768 kHz external crystal, resonator or oscillator, the internal low-power RC oscillator or the high-speed external clock divided by 128. The internal low-speed RC has a typical frequency of 32 kHz. The RTC can be calibrated using an external 512 Hz output to compensate for any natural quartz deviation.

Two alarm registers are used to generate an alarm at a specific time and calendar fields can be independently masked for alarm comparison. To generate a periodic interrupt, a 16-bit programmable binary auto-reload downcounter with programmable resolution is available and allows automatic wakeup and periodic alarms from every 120 μ s to every 36 hours.

A 20-bit prescaler is used for the time base clock. It is by default configured to generate a time base of 1 second from a clock at 32.768 kHz.

The backup registers are 32-bit registers used to store 80 bytes of user application data when V_{DD} power is not present. Backup registers are not reset by a system, a power reset, or when the device wakes up from the Standby mode (see [Section 3.18: Low-power modes](#)).

Additional 32-bit registers contain the programmable alarm subseconds, seconds, minutes, hours, day, and date.

The RTC and backup registers are supplied through a switch that is powered either from the V_{DD} supply when present or from the V_{BAT} pin.

3.18 Low-power modes

The devices support three low-power modes to achieve the best compromise between low power consumption, short startup time and available wakeup sources:

- **Sleep mode**

In Sleep mode, only the CPU is stopped. All peripherals continue to operate and can wake up the CPU when an interrupt/event occurs.

To further reduce the power consumption, the Flash memory can be switched off before entering in Sleep mode. Note that this requires a code execution from the RAM.

- **Stop mode**

The Stop mode achieves the lowest power consumption while retaining the contents of SRAM and registers. All clocks in the 1.2 V domain are stopped, the PLL, the HSI RC

and the HSE crystal oscillators are disabled. The voltage regulator can also be put either in normal or in low-power mode.

The RTC and the low-power timer (LPTIM1) can remain active in Stop mode. They can consequently be used to wake up the device from this mode.

The device can be woken up from the Stop mode by any of the EXTI line (the EXTI line source can be one of the 16 external lines, the PVD output, LPTIM1, the RTC alarm/ wakeup/ tamper/ time stamp events).

- **Standby mode**

The Standby mode is used to achieve the lowest power consumption. The internal voltage regulator is switched off so that the entire 1.2 V domain is powered off. The PLL, the HSI RC and the HSE crystal oscillators are also switched off. After entering Standby mode, the SRAM and register contents are lost except for registers in the backup domain when selected.

The device exits the Standby mode when an external reset (NRST pin), an IWDG reset, a rising edge on the WKUP pin, or an RTC alarm/ wakeup/ tamper/time stamp event occurs.

Standby mode is not supported when the embedded voltage regulator is bypassed and the 1.2 V domain is controlled by an external power.

3.19 V_{BAT} operation

The VBAT pin allows to power the device V_{BAT} domain from an external battery, an external super-capacitor, or from V_{DD} when no external battery and an external super-capacitor are present.

V_{BAT} operation is activated when V_{DD} is not present.

The VBAT pin supplies the RTC and the backup registers.

Note: When the microcontroller is supplied from VBAT, external interrupts and RTC alarm/events do not exit it from V_{BAT} operation. When PDR_ON pin is not connected to V_{DD} (internal Reset OFF), the V_{BAT} functionality is no more available and VBAT pin should be connected to V_{DD} .

3.20 Timers and watchdogs

The devices embed one advanced-control timer, four general purpose timers, one low power timer, two watchdog timers and one SysTick timer.

All timer counters can be frozen in debug mode.

[Table 5](#) compares the features of the advanced-control and general-purpose timers.

Table 5. Timer feature comparison

Timer type	Timer	Counter resolution	Counter type	Prescaler factor	DMA request generation	Capture/compare channels	Complementary output	Max. interface clock (MHz)	Max. timer clock (MHz)
Advanced-control	TIM1	16-bit	Up, Down, Up/down	Any integer between 1 and 65536	Yes	4	Yes	100	100
General purpose	TIM5	32-bit	Up, Down, Up/down	Any integer between 1 and 65536	Yes	4	No	50	100
	TIM9	16-bit	Up	Any integer between 1 and 65536	No	2	No	100	100
	TIM11	16-bit	Up	Any integer between 1 and 65536	No	1	No	100	100
Basic	TIM6	16-bit	Up	Any integer between 1 and 65536	Yes	0	No	50	100
Low-power	LPTIM1	16-bit	Up	Between 1 and 128	No	2	No	50	100

3.20.1 Advanced-control timers (TIM1)

The advanced-control timer (TIM1) can be seen as three-phase PWM generator multiplexed on 4 independent channels. It has complementary PWM outputs with programmable inserted dead times. It can also be considered as a complete general-purpose timer. Its 4 independent channels can be used for:

- Input capture
- Output compare
- PWM generation (edge- or center-aligned modes)
- One-pulse mode output

If configured as standard 16-bit timers, it has the same features as the general-purpose TIMx timers. If configured as a 16-bit PWM generator, it has full modulation capability (0-100%).

The advanced-control timer can work together with the TIMx timers via the Timer Link feature for synchronization or event chaining.

TIM1 supports independent DMA request generation.

3.20.2 General-purpose timers (TIM5, TIM9 and TIM11)

There are three synchronizable general-purpose timers embedded in the STM32F410x8/B (see [Table 5](#) for differences).

- **TIM5**

The STM32F410x8/B devices includes a full-featured general-purpose timer, TIM5. TIM5 timer is based on a 32-bit auto-reload up/downcounter and a 16-bit prescaler. It features four independent channels for input capture/output compare, PWM or one-pulse mode output.

TIM5 can operate in conjunction with the other general-purpose timers and TIM1 advanced-control timer via the Timer Link feature for synchronization or event chaining. TIM5 general-purpose timer can be used to generate PWM output.

All TIM5 channels have independent DMA request generation. They are capable of handling quadrature (incremental) encoder signals and the digital outputs from 1 to 4 hall-effect sensors.

- **TIM9 and TIM11**

These timers are based on a 16-bit auto-reload upcounter and a 16-bit prescaler. TIM11 features one independent channel, whereas TIM9 has two independent channels for input capture/output compare, PWM or one-pulse mode output. They can be synchronized with TIM5 full-featured general-purpose timer or used as simple time bases.

3.20.3 Basic timer (TIM6)

This timer is mainly used for DAC triggering and waveform generation. It can also operate as generic 16-bit timers.

TIM6 supports independent DMA request generation.

3.20.4 Low-power timer (LPTIM1)

The devices embed one low-power timer. This timer features an independent clock and runs in Stop mode if it is clocked by LSE, LSI or by an external clock. It is able to wake up the system from Stop mode.

The low-power timer main features are the following:

- 16-bit up counter with 16-bit autoreload register
- 16-bit compare register
- Configurable output: pulse, PWM
- Continuous/ one shot mode
- Selectable software/hardware input trigger
- Selectable clock source
 - Internal clock sources: LSE, LSI, HSI or APB1 clock
 - External clock source over LPTIM input (working even when no internal clock source is running and used by pulse-counter applications).
- Programmable digital glitch filter
- Encoder mode
- Active in Stop mode.

3.20.5 Independent watchdog

The independent watchdog is based on a 12-bit downcounter and 8-bit prescaler. It is clocked from an independent 32 kHz internal RC and as it operates independently from the main clock, it can operate in Stop and Standby modes. It can be used either as a watchdog to reset the device when a problem occurs, or as a free-running timer for application timeout management. It is hardware- or software-configurable through the option bytes.

3.20.6 Window watchdog

The window watchdog is based on a 7-bit downcounter that can be set as free-running. It can be used as a watchdog to reset the device when a problem occurs. It is clocked from the main clock. It has an early warning interrupt capability and the counter can be frozen in debug mode.

3.20.7 SysTick timer

This timer is dedicated to real-time operating systems, but could also be used as a standard downcounter. It features:

- A 24-bit downcounter
- Autoreload capability
- Maskable system interrupt generation when the counter reaches 0
- Programmable clock source.

3.21 Inter-integrated circuit interface (I²C)

The devices feature up to three I²C bus interfaces which can operate in multimaster and slave modes:

- One I²C interface supports the Standard mode (up to 100 kHz), Fast-mode (up to 400 kHz) modes and Fast-mode plus (up to 1 MHz).
- Two I²C interfaces support the Standard mode (up to 100 KHz) and the Fast mode (up to 400 KHz). Their frequency can be increased up to 1 MHz. For more details on the complete solution, refer to the nearest STMicroelectronics sales office.

All I²C interfaces features 7/10-bit addressing mode and 7-bit addressing mode (as slave) and embed a hardware CRC generation/verification.

They can be served by DMA and they support SMBus 2.0/PMBus.

The devices also include programmable analog and digital noise filters (see [Table 6](#)).

Table 6. Comparison of I2C analog and digital filters

	Analog filter	Digital filter
Pulse width of suppressed spikes	≥ 50 ns	Programmable length from 1 to 15 I2C peripheral clocks

3.22 Universal synchronous/asynchronous receiver transmitters (USART)

The devices embed three universal synchronous/asynchronous receiver transmitters (USART1, USART2 and USART6).

These three interfaces provide asynchronous communication, IrDA SIR ENDEC support, multiprocessor communication mode, single-wire half-duplex communication mode and have LIN Master/Slave capability. The USART1 and USART6 interfaces are able to communicate at speeds of up to 12.5 Mbit/s. The USART2 interface communicates at up to 6.25 bit/s.

USART1 and USART2 also provide hardware management of the CTS and RTS signals, Smart Card mode (ISO 7816 compliant) and SPI-like communication capability. All interfaces can be served by the DMA controller.

Table 7. USART feature comparison

USART name	Standard features	Modem (RTS/CTS)	LIN	SPI master	irDA	Smartcard (ISO 7816)	Max. baud rate in Mbit/s (oversampling by 16)	Max. baud rate in Mbit/s (oversampling by 8)	APB mapping
USART1	X	X ⁽¹⁾	X	X	X	X	6.25	12.5	APB2 (max. 100 MHz)
USART2	X	X ⁽¹⁾	X	X ⁽¹⁾	X	X ⁽¹⁾	3.12	6.25	APB1 (max. 50 MHz)
USART6 ⁽¹⁾	X	N.A	X	X ⁽¹⁾⁽²⁾	X	X ⁽¹⁾⁽²⁾	6.25	12.5	APB2 (max. 50 MHz)

1. Not available on WLCSP36 package.
2. Not available on UFQFPN48 package.

3.23 Serial peripheral interface (SPI)

The devices feature three SPIs in slave and master modes in full-duplex and simplex communication modes. SPI1 and SPI5 can communicate at up to 50 Mbit/s, SPI2 can communicate at up to 25 Mbit/s. The 3-bit prescaler gives 8 master mode frequencies and the frame is configurable to 8 bits or 16 bits. The hardware CRC generation/verification supports basic SD Card/MMC modes. All SPIs can be served by the DMA controller.

The SPI interface can be configured to operate in TI mode for communications in master mode and slave mode.

3.24 Inter-integrated sound (I²S)

Three standard I²S interfaces (multiplexed with SPI1 to SPI5) are available. They can be operated in master or slave mode, in simplex communication modes and can be configured to operate with a 16-/32-bit resolution as an input or output channel. All the I²Sx audio sampling frequencies from 8 kHz up to 192 kHz are supported. When either or both of the I²S interfaces is/are configured in master mode, the master clock can be output to the external DAC/CODEC at 256 times the sampling frequency.

All I²Sx can be served by the DMA controller.

3.25 Random number generator (RNG)

All devices embed an RNG that delivers 32-bit random numbers generated by an integrated analog circuit.

3.26 General-purpose input/outputs (GPIOs)

Each of the GPIO pins can be configured by software as output (push-pull or open-drain, with or without pull-up or pull-down), as input (floating, with or without pull-up or pull-down) or as peripheral alternate function. Most of the GPIO pins are shared with digital or analog alternate functions. All GPIOs are high-current-capable and have speed selection to better manage internal noise, power consumption and electromagnetic emission.

The I/O configuration can be locked if needed by following a specific sequence in order to avoid spurious writing to the I/Os registers.

Fast I/O handling allowing maximum I/O toggling up to 100 MHz.

3.27 Analog-to-digital converter (ADC)

One 12-bit analog-to-digital converter is embedded and shares up to 16 external channels, performing conversions in the single-shot or scan mode. In scan mode, automatic conversion is performed on a selected group of analog inputs.

The ADC can be served by the DMA controller. An analog watchdog feature allows very precise monitoring of the converted voltage of one, some or all selected channels. An interrupt is generated when the converted voltage is outside the programmed thresholds.

To synchronize A/D conversion and timers, the ADCs could be triggered by any of TIM1 or TIM5 timer.

3.28 Temperature sensor

The temperature sensor has to generate a voltage that varies linearly with temperature. The conversion range is between 1.7 V and 3.6 V. The temperature sensor is internally connected to the ADC_IN18 input channel which is used to convert the sensor output voltage into a digital value. Refer to the reference manual for additional information.

As the offset of the temperature sensor varies from chip to chip due to process variation, the internal temperature sensor is mainly suitable for applications that detect temperature changes instead of absolute temperatures. If an accurate temperature reading is needed, then an external temperature sensor part should be used.

3.29 Digital-to-analog converter (DAC)

One 12-bit buffered DAC channel can be used to convert a digital signal into an analog voltage signal output. The chosen design structure is composed of integrated resistor strings and an amplifier in inverting configuration.

This digital interface supports the following features:

- 8-bit or 12-bit monotonic output
- Buffer offset calibration (factory and user trimming)
- Left or right data alignment in 12-bit mode
- Synchronized update capability
- Noise-wave generation

- Triangular-wave generation
- DMA capability for each channel
- External triggers for conversion
- Sample and hold low-power mode, with internal or external capacitor

The DAC channel is triggered through TIM6 update output that is also connected to different DMA channels.

3.30 Serial wire JTAG debug port (SWJ-DP)

The Arm SWJ-DP interface is embedded, and is a combined JTAG and serial wire debug port that enables either a serial wire debug or a JTAG probe to be connected to the target.

Debug is performed using 2 pins only instead of 5 required by the JTAG (JTAG pins could be re-use as GPIO with alternate function): the JTAG TMS and TCK pins are shared with SWDIO and SWCLK, respectively, and a specific sequence on the TMS pin is used to switch between JTAG-DP and SW-DP.

3.31 Embedded Trace Macrocell™

The Arm Embedded Trace Macrocell provides a greater visibility of the instruction and data flow inside the CPU core by streaming compressed data at a very high rate from the STM32F410x8/B through a small number of ETM pins to an external hardware trace port analyzer (TPA) device. The TPA is connected to a host computer using any high-speed channel available. Real-time instruction and data flow activity can be recorded and then formatted for display on the host computer that runs the debugger software. TPA hardware is commercially available from common development tool vendors.

The Embedded Trace Macrocell operates with third party debugger software tools.

Figure 7. UFQFPN48 pinout

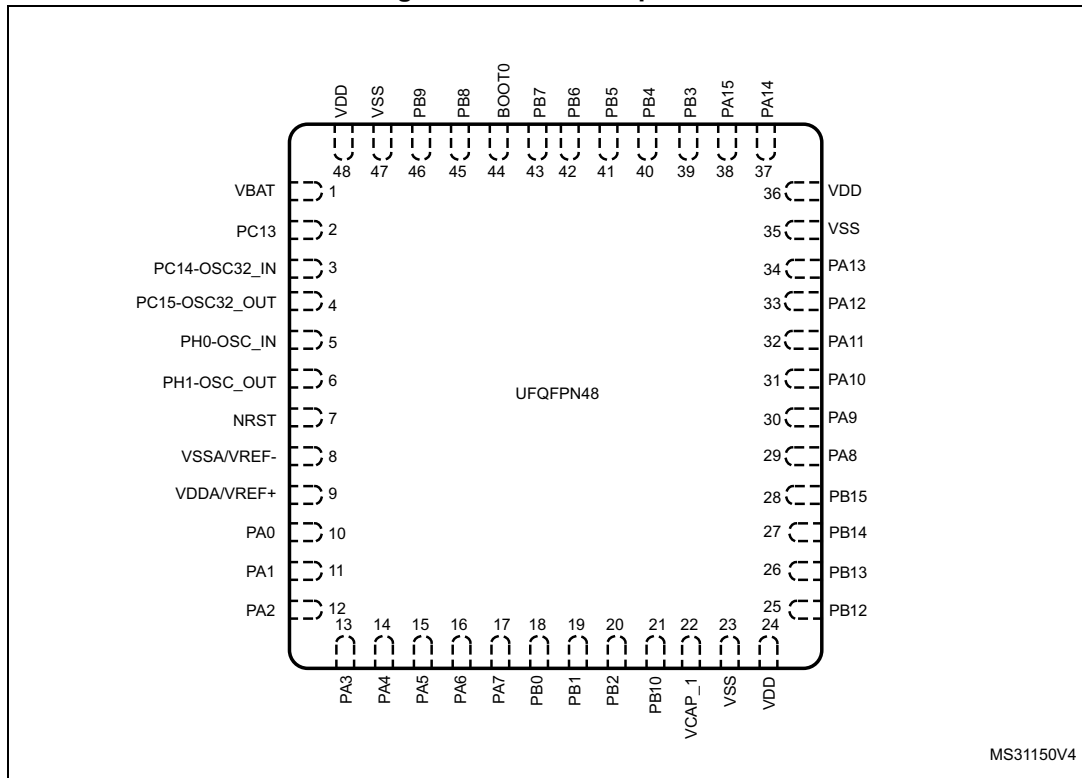

1. The above figure shows the package top view.

Figure 8. UFBGA64 pinout

	1	2	3	4	5	6	7	8
A	PC14-OSC32_IN	VBAT	PB9	BOOT0	PB3	PC12	PA15	PA12
B	PC15-OSC32_OUT	PC13-ANTI_TAMP	PB8	PB7	PB11	PC11	PA14	PA9
C	PH0 - OSC_IN	VSS	PDR_ON	PB6	PB4	PC10	PA13	PA8
D	PH1 - OSC_OUT	VDD	PC0	PB5	PC3	VSS	PA11	PC9
E	NRST	PC1	PC2	VDD	VDD	PA10	PC7	PC8
F	VSSA	PC3	PA2	PA5	PB0	PC6	PB15	PB14
G	VREF+	PA0-WKUP	PA3	PA6	PC4	PB1	PB10	PB13
H	VDDA	PA1	PA4	PA7	PC5	PB2	VCAP_1	PB12

MSv43092V1

1. The above figure shows the package top view.

Figure 9. WLCSP36 pinout

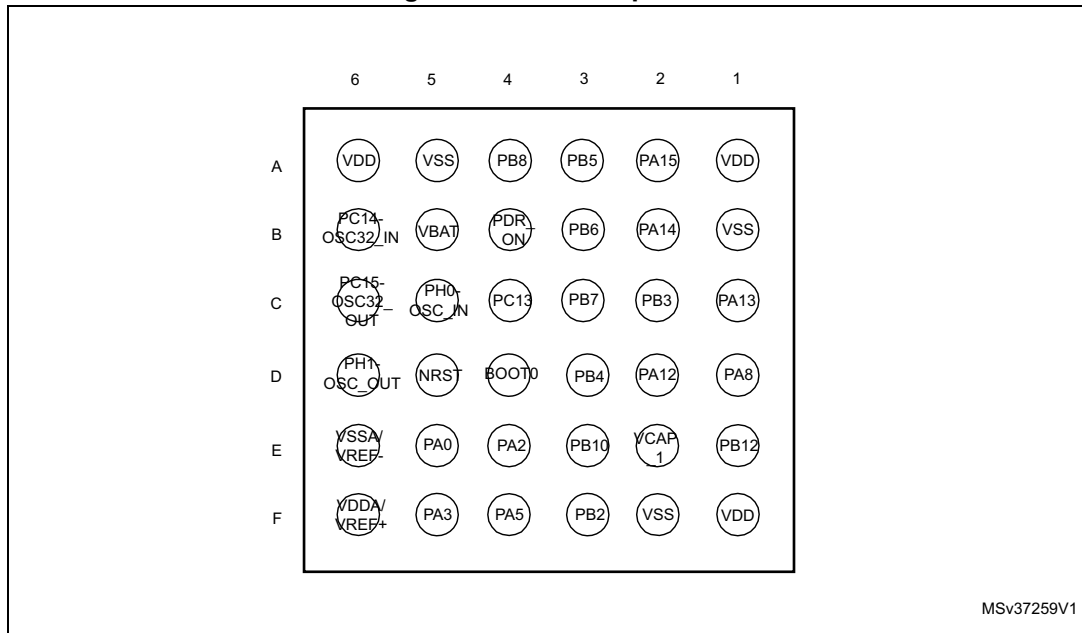

1. The above figure shows the package bump side.

Table 8. Legend/abbreviations used in the pinout table

Name	Abbreviation	Definition
Pin name	Unless otherwise specified in brackets below the pin name, the pin function during and after reset is the same as the actual pin name	
Pin type	S	Supply pin
	I	Input only pin
	I/O	Input/ output pin
I/O structure	FT	5 V tolerant I/O
	TC	Standard 3.3 V I/O
	B	Dedicated BOOT0 pin
	NRST	Bidirectional reset pin with embedded weak pull-up resistor
Notes	Unless otherwise specified by a note, all I/Os are set as floating inputs during and after reset	
Alternate functions	Functions selected through GPIOx_AFR registers	
Additional functions	Functions directly selected/enabled through peripheral registers	

Table 9. STM32F410x8/B pin definitions

Pin Number					Pin name (function after reset) ⁽¹⁾	Pin type	I/O structure	Notes	Alternate functions	Additional functions
WLCSP36	LQFP48	UFQFPN48	LQFP64	UFBGA64						
B5	1	1	1	A2	VBAT	S	-	-	-	VBAT
-	-	-	-	C2	VSS	S	-	-	-	-
C4	2	2	2	B2	PC13	I/O	FT	(2)(3)	EVENTOUT	RTC_TAMP1, RTC_OUT, RTC_TS
B6	3	3	3	A1	PC14- OSC32_IN	I/O	FT	(2)(3) (4)	EVENTOUT	OSC32_IN
C6	4	4	4	B1	PC15- OSC32_OUT	I/O	FT	(2)(4)	EVENTOUT	OSC32_OUT
-	-	-	-	D2	VDD	S	-	-	-	-
C5	5	5	5	C1	PH0 - OSC_IN	I/O	FT	(4)	EVENTOUT	OSC_IN
D6	6	6	6	D1	PH1 - OSC_OUT	I/O	FT	(4)	EVENTOUT	OSC_OUT
D5	7	7	7	E1	NRST	NR ST	-	-	-	-
-	-	-	8	D3	PC0	I/O	FT	-	LPTIM1_IN1, EVENTOUT	ADC1_10, WKUP2
-	-	-	9	E2	PC1	I/O	FT	-	LPTIM1_OUT, EVENTOUT	ADC1_11, WKUP3
-	-	-	10	E3	PC2	I/O	FT	-	LPTIM1_IN2, SPI2_MISO, EVENTOUT	ADC1_12
-	-	-	11	F2	PC3	I/O	FT	-	LPTIM1_ETR, SPI2_MOSI/I2S2_SD, EVENTOUT	ADC1_13
E6	8	8	12	F1	VSSA/VREF-	S	-	-	-	-
F6	9	9	13	-	VDDA/VREF+	S	-	-	-	-
-	-	-	-	G1	VREF+	S	-	-	-	-
-	-	-	-	H1	VDDA	S	-	-	-	-
E5	10	10	14	G2	PA0	I/O	FT	-	TIM5_CH1, USART2_CTS, EVENTOUT	ADC1_0, WKUP1
-	11	11	15	H2	PA1	I/O	FT	-	TIM5_CH2, USART2_RTS, EVENTOUT	ADC1_1

Table 9. STM32F410x8/B pin definitions (continued)

Pin Number					Pin name (function after reset) ⁽¹⁾	Pin type	I/O structure	Notes	Alternate functions	Additional functions
WLCSP36	LQFP48	UFQFPN48	LQFP64	UFPGA64						
E4	12	12	16	F3	PA2	I/O	FT	-	TIM5_CH3, TIM9_CH1, I2S2_CKIN, USART2_TX, EVENTOUT	ADC1_2
F5	13	13	17	G3	PA3	I/O	FT	-	TIM5_CH4, TIM9_CH2, I2S2_MCK, USART2_RX, EVENTOUT	ADC1_3
-	-	-	18	D5	VSS	S	-	-	-	-
-	-	-	19	E4	VDD	S	-	-	-	-
-	14	14	20	H3	PA4	I/O	FT	-	SPI1_NSS/I2S1_WS, USART2_CK, EVENTOUT	ADC1_4
F4	15	15	21	F4	PA5	I/O	TC	-	SPI1_SCK/I2S1_CK, EVENTOUT	ADC1_5, DAC_OUT1
-	16	16	22	G4	PA6	I/O	FT	-	TIM1_BKIN, SPI1_MISO, I2S2_MCK, EVENTOUT	ADC1_6
-	17	17	23	H4	PA7	I/O	FT	-	TIM1_CH1N, SPI1_MOSI/I2S1_SD, EVENTOUT	ADC1_7
-	-	-	24	G5	PC4	I/O	FT	-	TIM9_CH1, EVENTOUT	ADC1_14
-	-	-	25	H5	PC5	I/O	FT	-	TIM9_CH2, I2C4_SMBA, EVENTOUT	ADC1_15
-	18	18	26	F5	PB0	I/O	FT	-	TIM1_CH2N, SPI5_SCK/I2S5_CK, EVENTOUT	ADC1_8
-	19	19	27	G6	PB1	I/O	TC	-	TIM1_CH3N, SPI5_NSS/I2S5_WS, EVENTOUT	ADC1_9
F3	20	20	28	H6	PB2	I/O	FT	-	LPTIM1_OUT, EVENTOUT	BOOT1

Table 9. STM32F410x8/B pin definitions (continued)

Pin Number					Pin name (function after reset) ⁽¹⁾	Pin type	I/O structure	Notes	Alternate functions	Additional functions
WLCSP36	LQFP48	UFQFPN48	LQFP64	UFBGA64						
E3	21	21	29	G7	PB10	I/O	FT	-	I2C2_SCL, SPI2_SCK/I2S2_CK, I2S1_MCK, I2C4_SCL, EVENTOUT	-
E2	22	22	30	H7	VCAP_1	S	-	-	-	-
F2	23	23	31	D6	VSS	S	-	-	-	-
F1	24	24	32	E5	VDD	S	-	-	-	-
E1	25	25	33	H8	PB12	I/O	FT	-	TIM1_BKIN, TIM5_CH1, I2C2_SMBA, SPI2_NSS/I2S2_WS, EVENTOUT	-
-	26	26	34	G8	PB13	I/O	FT	-	TIM1_CH1N, I2C4_SMBA, SPI2_SCK/I2S2_CK, EVENTOUT	-
-	27	27	35	F8	PB14	I/O	FT	-	TIM1_CH2N, I2C4_SDA, SPI2_MISO, EVENTOUT	-
-	28	28	36	F7	PB15	I/O	FT	-	RTC_50Hz, TIM1_CH3N, I2C4_SCL, SPI2_MOSI/I2S2_SD, EVENTOUT	-
-	-	-	37	F6	PC6	I/O	FT	-	TRACECLK, I2C4_SCL, I2S2_MCK, USART6_TX, EVENTOUT	-
-	-	-	38	E7	PC7	I/O	FT	-	I2C4_SDA, SPI2_SCK/I2S2_CK, I2S1_MCK, USART6_RX, EVENTOUT	-
-	-	-	39	E8	PC8	I/O	FT	-	USART6_CK, EVENTOUT	-
-	-	-	40	D8	PC9	I/O	FT	-	MCO_2, I2C4_SDA, I2S2_CKIN, EVENTOUT	-

Table 9. STM32F410x8/B pin definitions (continued)

Pin Number					Pin name (function after reset) ⁽¹⁾	Pin type	I/O structure	Notes	Alternate functions	Additional functions
WLCSP36	LQFP48	UFQFPN48	LQFP64	UFPGA64						
D1	29	29	41	C8	PA8	I/O	FT	-	MCO_1, TIM1_CH1, I2C4_SCL, USART1_CK, EVENTOUT	-
-	30	30	42	B8	PA9	I/O	FT	-	TIM1_CH2, USART1_TX, EVENTOUT	-
-	31	31	43	E6	PA10	I/O	FT	-	TIM1_CH3, SPI5_MOSI/I2S5_SD, USART1_RX, EVENTOUT	-
-	32	32	44	D7	PA11	I/O	FT	-	TIM1_CH4, USART1_CTS, USART6_TX, EVENTOUT	-
D2	33	33	45	A8	PA12	I/O	FT	-	TIM1_ETR, SPI5_MISO, USART1_RTS, USART6_RX, EVENTOUT	-
C1	34	34	46	C7	PA13	I/O	FT	-	JTMS-SWDIO, EVENTOUT	-
B1	35	35	47	D5	VSS	S	-	-	-	-
-	36	36	48	-	VDD	S	-	-	-	-
A1	-	-	-	-	VDD	S	-	-	-	-
B2	37	37	49	B7	PA14	I/O	FT	-	JTCK-SWCLK, EVENTOUT	-
A2	38	38	50	A7	PA15	I/O	FT	-	JTDI, SPI1_NSS/I2S1_WS, USART1_TX, EVENTOUT	-
-	-	-	51	C6	PC10	I/O	FT	-	TRACED0, TIM5_CH2, EVENTOUT	-
-	-	-	52	B6	PC11	I/O	FT	-	TRACED1, TIM5_CH3, EVENTOUT	-
-	-	-	53	A6	PC12	I/O	FT	-	TRACED2, TIM11_CH1, EVENTOUT	-

Table 9. STM32F410x8/B pin definitions (continued)

Pin Number					Pin name (function after reset) ⁽¹⁾	Pin type	I/O structure	Notes	Alternate functions	Additional functions
WLCSP36	LQFP48	UFQFPN48	LQFP64	UFPGA64						
-	-	-	54	B5	PB11	I/O	FT	-	TRACED3, TIM5_CH4, I2C2_SDA, I2S2_CKIN, EVENTOUT	-
C2	39	39	55	A5	PB3	I/O	FT	-	JTDO-SWO, I2C4_SDA, SPI1_SCK/I2S1_CK, USART1_RX, I2C2_SDA, EVENTOUT	-
D3	40	40	56	C5	PB4	I/O	FT	-	JTRST, SPI1_MISO, EVENTOUT	-
A3	41	41	57	D4	PB5	I/O	FT	-	LPTIM1_IN1, I2C1_SMBA, SPI1_MOSI/I2S1_SD, EVENTOUT	-
B3	42	42	58	C4	PB6	I/O	FT	-	LPTIM1_ETR, I2C1_SCL, USART1_TX, EVENTOUT	-
C3	43	43	59	B4	PB7	I/O	FT	-	LPTIM1_IN2, I2C1_SDA, USART1_RX, EVENTOUT	-
D4	44	44	60	A4	BOOT0	I	B	-	-	BOOT0
A4	45	45	61	B3	PB8	I/O	FT	-	LPTIM1_OUT, I2C1_SCL, SPI5_MOSI/I2S5_SD, EVENTOUT	-
-	-	46	62	A3	PB9	I/O	FT	-	TIM11_CH1, I2C1_SDA, SPI2_NSS/I2S2_WS, I2C2_SDA, EVENTOUT	-
A5	46	47	63	-	VSS	S	-	-	-	-
B4	47	-	-	C3	PDR_ON	I	FT	-	-	-
A6	48	48	64	-	VDD	S	-	-	-	-

1. Function availability depends on the chosen device.

2. PC13, PC14 and PC15 are supplied through the power switch. Since the switch only sinks a limited amount of current (3 mA), the use of GPIOs PC13 to PC15 in output mode is limited:
 - The speed should not exceed 2 MHz with a maximum load of 30 pF.
 - These I/Os must not be used as a current source (e.g. to drive an LED).
3. Main function after the first backup domain power-up. Later on, it depends on the contents of the RTC registers even after reset (because these registers are not reset by the main reset). For details on how to manage these I/Os, refer to the RTC register description sections in the STM32F410x8/Reference manual.
4. FT = 5 V tolerant except when in analog mode or oscillator mode (for PC14, PC15, PH0 and PH1).



Table 10. Alternate function mapping

Port		AF0	AF1	AF2	AF3	AF4	AF5	AF6	AF7	AF8	AF9	AF10	AF11	AF12	AF13	AF14	AF15
		SYS_AF	TIM1/LPTIM1	TIM5	TIM9/ TIM11	I2C1/I2C2 /I2C4	SPI1/I2S1/S PI2/I2S2	SPI1/I2S1/ SPI2/I2S2/ SPI5/I2S5	USART1/ USART2	USART6	I2C2/ I2C4	-	-	-	-	-	-
Port A	PA0	-	-	TIM5_ CH1	-	-	-	-	USART2_ CTS	-	-	-	-	-	-	-	EVENTOUT
	PA1	-	-	TIM5_ CH2	-	-	-	-	USART2_ RTS	-	-	-	-	-	-	-	EVENTOUT
	PA2	-	-	TIM5_ CH3	TIM9_ CH1	-	I2S2_ CKIN	-	USART2_ TX	-	-	-	-	-	-	-	EVENTOUT
	PA3	-	-	TIM5_ CH4	TIM9_ CH2	-	I2S2_MCK	-	USART2_ RX	-	-	-	-	-	-	-	EVENTOUT
	PA4	-	-	-	-	-	SPI1_NSS/ I2S1_WS	-	USART2_ CK	-	-	-	-	-	-	-	EVENTOUT
	PA5	-	-	-	-	-	SPI1_SCK/ I2S1_CK	-	-	-	-	-	-	-	-	-	EVENTOUT
	PA6	-	TIM1_BKIN	-	-	-	SPI1_MISO	I2S2_MCK	-	-	-	-	-	-	-	-	EVENTOUT
	PA7	-	TIM1_CH1N	-	-	-	SPI1_MOSI /I2S1_SD	-	-	-	-	-	-	-	-	-	EVENTOUT
	PA8	MCO_1	TIM1_CH1	-	-	I2C4_ SCL	-	-	USART1_ CK	-	-	-	-	-	-	-	EVENTOUT
	PA9	-	TIM1_CH2	-	-	-	-	-	USART1_ TX	-	-	-	-	-	-	-	EVENTOUT
	PA10	-	TIM1_CH3	-	-	-	-	SPI5_MOSI /I2S5_SD	USART1_ RX	-	-	-	-	-	-	-	EVENTOUT
	PA11	-	TIM1_CH4	-	-	-	-	-	USART1_ CTS	USART6_ TX	-	-	-	-	-	-	EVENTOUT
	PA12	-	TIM1_ETR	-	-	-	-	SPI5_MISO	USART1_ RTS	USART6_ RX	-	-	-	-	-	-	EVENTOUT
	PA13	JTMS- SWDIO	-	-	-	-	-	-	-	-	-	-	-	-	-	-	EVENTOUT
	PA14	JTCK- SWCLK	-	-	-	-	-	-	-	-	-	-	-	-	-	-	EVENTOUT
PA15	JTDI	-	-	-	-	-	SPI1_NSS/ I2S1_WS	USART1_ TX	-	-	-	-	-	-	-	EVENTOUT	



Table 10. Alternate function mapping (continued)

Port	AF0	AF1	AF2	AF3	AF4	AF5	AF6	AF7	AF8	AF9	AF10	AF11	AF12	AF13	AF14	AF15	
	SYS_AF	TIM1/LPTIM1	TIM5	TIM9/ TIM11	I2C1/I2C2 /I2C4	SPI1/I2S1/S PI2/I2S2	SPI1/I2S1/ SPI2/I2S2/ SPI5/I2S5	USART1/ USART2	USART6	I2C2/ I2C4	-	-	-	-	-	SYS_AF	
Port B	PB0	-	TIM1_CH2N	-	-	-	-	SPI5_SCK/ I2S5_CK	-	-	-	-	-	-	-	EVENTOUT	
	PB1	-	TIM1_CH3N	-	-	-	-	SPI5_NSS/ I2S5_WS	-	-	-	-	-	-	-	EVENTOUT	
	PB2	-	LPTIM1_OUT	-	-	-	-	-	-	-	-	-	-	-	-	EVENTOUT	
	PB3	JTDO- SWO	-	-	-	I2C4_ SDA	SPI1_SCK/ I2S1_CK	-	USART1_ RX	-	I2C2_ SDA	-	-	-	-	-	EVENTOUT
	PB4	JTRST	-	-	-	-	SPI1_MISO	-	-	-	-	-	-	-	-	EVENTOUT	
	PB5	-	LPTIM1_IN1	-	-	I2C1_ SMBA	SPI1_MOSI /I2S1_SD	-	-	-	-	-	-	-	-	-	EVENTOUT
	PB6	-	LPTIM1_ETR	-	-	I2C1_ SCL	-	-	USART1_ TX	-	-	-	-	-	-	-	EVENTOUT
	PB7	-	LPTIM1_IN2	-	-	I2C1_ SDA	-	-	USART1_ RX	-	-	-	-	-	-	-	EVENTOUT
	PB8	-	LPTIM1_OUT	-	-	I2C1_ SCL	-	SPI5_MOSI /I2S5_SD	-	-	-	-	-	-	-	-	EVENTOUT
	PB9	-	-	-	TIM11_ CH1	I2C1_ SDA	SPI2_NSS/ I2S2_WS	-	-	-	I2C2_ SDA	-	-	-	-	-	EVENTOUT
	PB10	-	-	-	-	I2C2_ SCL	SPI2_SCK/ I2S2_CK	I2S1_MCK	-	-	I2C4_ SCL	-	-	-	-	-	EVENTOUT
	PB11	TRACED3	-	TIM5_ CH4	-	I2C2_ SDA	I2S2_CKIN	-	-	-	-	-	-	-	-	-	EVENTOUT
	PB12	-	TIM1_BKIN	TIM5_ CH1	-	I2C2_ SMBA	SPI2_NSS/ I2S2_WS	-	-	-	-	-	-	-	-	-	EVENTOUT
	PB13	-	TIM1_CH1N	-	-	I2C4_ SMBA	SPI2_SCK /I2S2_CK	-	-	-	-	-	-	-	-	-	EVENTOUT
	PB14	-	TIM1_CH2N	-	-	I2C4_ SDA	SPI2_MISO	-	-	-	-	-	-	-	-	-	EVENTOUT
PB15	RTC_ 50Hz	TIM1_CH3N	-	-	I2C4_ SCL	SPI2_MOSI /I2S2_SD	-	-	-	-	-	-	-	-	-	EVENTOUT	



Table 10. Alternate function mapping (continued)

Port	AF0	AF1	AF2	AF3	AF4	AF5	AF6	AF7	AF8	AF9	AF10	AF11	AF12	AF13	AF14	AF15
	SYS_AF	TIM1/LPTIM1	TIM5	TIM9/ TIM11	I2C1/I2C2 /I2C4	SPI1/I2S1/S PI2/I2S2	SPI1/I2S1/ SPI2/I2S2/ SPI5/I2S5	USART1/ USART2	USART6	I2C2/ I2C4	-	-	-	-	-	SYS_AF
Port C	PC0	-	LPTIM1_IN1	-	-	-	-	-	-	-	-	-	-	-	-	EVENTOUT
	PC1	-	LPTIM1_OUT	-	-	-	-	-	-	-	-	-	-	-	-	EVENTOUT
	PC2	-	LPTIM1_IN2	-	-	-	SPI2_MISO	-	-	-	-	-	-	-	-	EVENTOUT
	PC3	-	LPTIM1_ETR	-	-	-	SPI2_MOSI /I2S2_SD	-	-	-	-	-	-	-	-	EVENTOUT
	PC4	-	-	-	TIM9_ CH1	-	-	-	-	-	-	-	-	-	-	EVENTOUT
	PC5	-	-	-	TIM9_ CH2	I2C4_ SMBA	-	-	-	-	-	-	-	-	-	EVENTOUT
	PC6	TRACE CLK	-	-	-	I2C4_ SCL	I2S2_MCK	-	-	USART6_ TX	-	-	-	-	-	EVENTOUT
	PC7	-	-	-	-	I2C4_ SDA	SPI2_SCK/ I2S2_CK	I2S1_MCK	-	USART6_ RX	-	-	-	-	-	EVENTOUT
	PC8	-	-	-	-	-	-	-	-	USART6_ CK	-	-	-	-	-	EVENTOUT
	PC9	MCO_2	-	-	-	I2C4_ SDA	I2S2_CKIN	-	-	-	-	-	-	-	-	EVENTOUT
	PC10	TRACED0	-	TIM5_ CH2	-	-	-	-	-	-	-	-	-	-	-	EVENTOUT
	PC11	TRACED1	-	TIM5_ CH3	-	-	-	-	-	-	-	-	-	-	-	EVENTOUT
	PC12	TRACED2	-	-	TIM11_ CH1	-	-	-	-	-	-	-	-	-	-	EVENTOUT
	PC13	-	-	-	-	-	-	-	-	-	-	-	-	-	-	EVENTOUT
	PC14	-	-	-	-	-	-	-	-	-	-	-	-	-	-	EVENTOUT
PC15	-	-	-	-	-	-	-	-	-	-	-	-	-	-	EVENTOUT	
Port H	PH0	-	-	-	-	-	-	-	-	-	-	-	-	-	-	EVENTOUT
	PH1	-	-	-	-	-	-	-	-	-	-	-	-	-	-	EVENTOUT

5 Memory mapping

The memory map is shown in [Figure 10](#).

Figure 10. Memory map

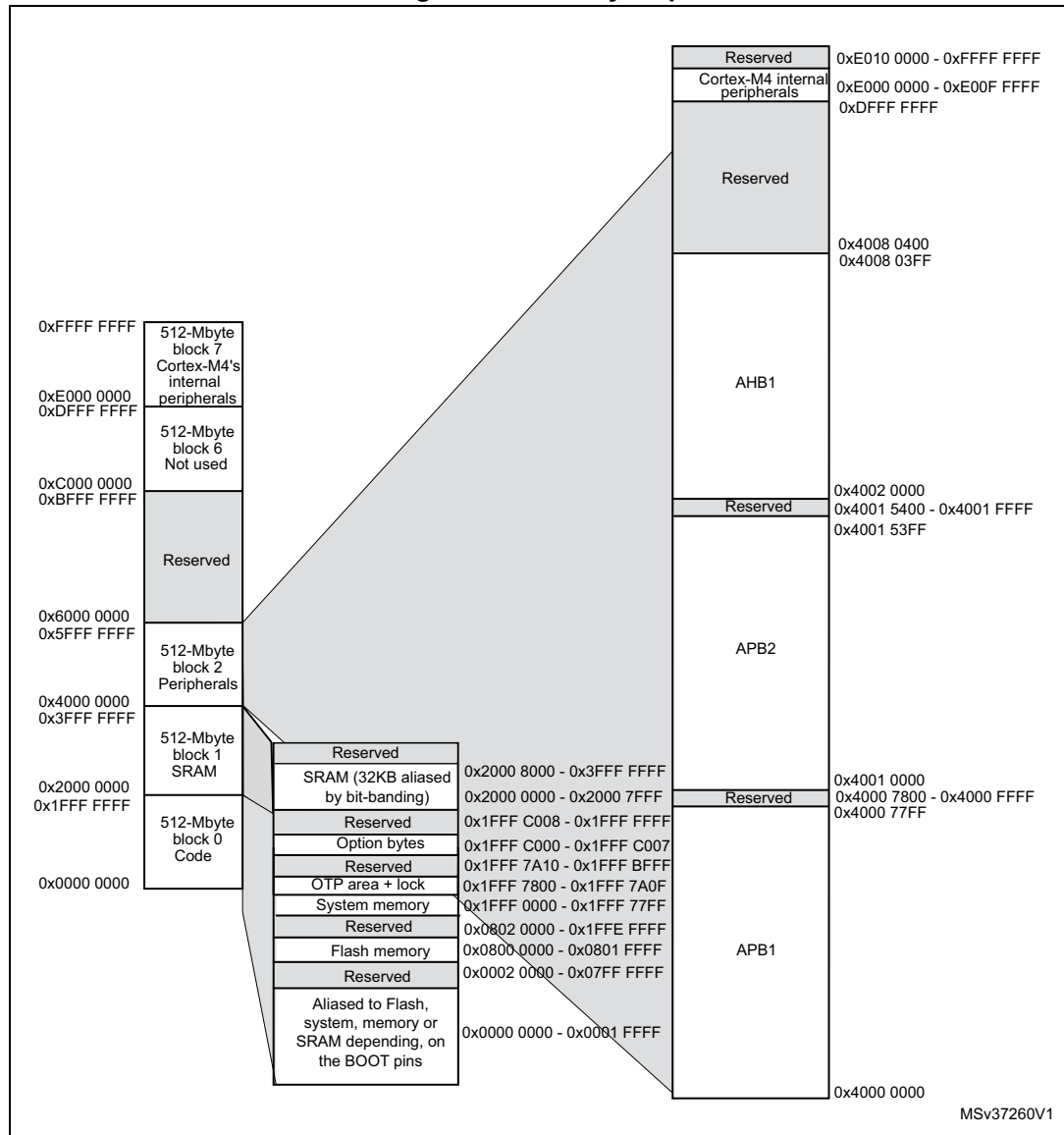

Table 11. STM32F410x8/B register boundary addresses⁽¹⁾

Bus	Boundary address	Peripheral
-	0xE010 0000 - 0xFFFF FFFF	Reserved
Cortex [®] -M4	0xE000 0000 - 0xE00F FFFF	Cortex-M4 internal peripherals
-	0x5000 0000 - 0xDFFF FFFF	Reserved
AHB1	0x4008 0400 - 0x4FFF FFFF	Reserved
	0x4008 0000 - 0x4008 03FF	RNG
	0x4002 6800 - 0x4007 FFFF	Reserved
	0x4002 6400 - 0x4002 67FF	DMA2
	0x4002 6000 - 0x4002 63FF	DMA1
	0x4002 5000 - 0x4002 4FFF	Reserved
	0x4002 3C00 - 0x4002 3FFF	Flash interface register
	0x4002 3800 - 0x4002 3BFF	RCC
	0x4002 3400 - 0x4002 37FF	Reserved
	0x4002 3000 - 0x4002 33FF	CRC
	0x4002 2800 - 0x4002 2FFF	Reserved
	0x4002 2400 - 0x4002 27FF	LPTIM1
	0x4002 2000 - 0x4002 23FF	Reserved
	0x4002 1C00 - 0x4002 1FFF	GPIOH
	0x4002 0C00 - 0x4002 1BFF	Reserved
	0x4002 0800 - 0x4002 0BFF	GPIOC
	0x4002 0400 - 0x4002 07FF	GPIOB
0x4002 0000 - 0x4002 03FF	GPIOA	

Table 11. STM32F410x8/B register boundary addresses⁽¹⁾

Bus	Boundary address	Peripheral
APB2	0x4001 5400- 0x4001 FFFF	Reserved
	0x4001 5000 - 0x4001 53FF	SPI5/I2S5
	0x4001 4C00- 0x4001 4FFF	Reserved
	0x4001 4800 - 0x4001 4BFF	TIM11
	0x4001 4400 - 0x4001 47FF	Reserved
	0x4001 4000 - 0x4001 43FF	TIM9
	0x4001 3C00 - 0x4001 3FFF	EXTI
	0x4001 3800 - 0x4001 3BFF	SYSCFG
	0x4001 3400 - 0x4001 37FF	Reserved
	0x4001 3000 - 0x4001 33FF	SPI1/I2S1
	0x4001 2400 - 0x4001 27FF	Reserved
	0x4001 2000 - 0x4001 23FF	ADC1
	0x4001 1800 - 0x4001 1FFF	Reserved
	0x4001 1400 - 0x4001 17FF	USART6
	0x4001 1000 - 0x4001 13FF	USART1
	0x4001 0400 - 0x4001 0FFF	Reserved
	0x4001 0000 - 0x4001 03FF	TIM1

Table 11. STM32F410x8/B register boundary addresses⁽¹⁾

Bus	Boundary address	Peripheral
APB1	0x4000 7800 - 0x4000 FFFF	Reserved
	0x4000 7400 - 0x4000 77FF	DAC
	0x4000 7000 - 0x4000 73FF	PWR
	0x4000 6400 - 0x4000 6FFF	Reserved
	0x4000 6000 - 0x4000 63FF	I2C4 FM+
	0x4000 5C00 - 0x4000 5FFF	Reserved
	0x4000 5800 - 0x4000 5BFF	I2C2
	0x4000 5400 - 0x4000 57FF	I2C1
	0x4000 4800 - 0x4000 53FF	Reserved
	0x4000 4400 - 0x4000 47FF	USART2
	0x4000 4000 - 0x4000 43FF	Reserved
	0x4000 3C00 - 0x4000 3FFF	SPI3 / I2S3
	0x4000 3800 - 0x4000 3BFF	SPI2 / I2S2
	0x4000 3400 - 0x4000 37FF	Reserved
	0x4000 3000 - 0x4000 33FF	IWDG
	0x4000 2C00 - 0x4000 2FFF	WWDG
	0x4000 2800 - 0x4000 2BFF	RTC & BKP Registers
	0x4000 1400 - 0x4000 27FF	Reserved
	0x4000 1000 - 0x4000 13FF	TIM6
	0x4000 0C00 - 0x4000 0FFF	TIM5
0x4000 0000 - 0x4000 0BFF	Reserved	

1. The gray color is used for reserved boundary address.

6 Electrical characteristics

6.1 Parameter conditions

Unless otherwise specified, all voltages are referenced to V_{SS} .

6.1.1 Minimum and maximum values

Unless otherwise specified the minimum and maximum values are guaranteed in the worst conditions of ambient temperature, supply voltage and frequencies by tests in production on 100% of the devices with an ambient temperature at $T_A = 25\text{ °C}$ and $T_A = T_{Amax}$ (given by the selected temperature range).

Data based on characterization results, design simulation and/or technology characteristics are indicated in the table footnotes and are not tested in production. Based on characterization, the minimum and maximum values refer to sample tests and represent the mean value plus or minus three times the standard deviation (mean $\pm 3\sigma$).

6.1.2 Typical values

Unless otherwise specified, typical data are based on $T_A = 25\text{ °C}$, $V_{DD} = 3.3\text{ V}$ (for the $1.7\text{ V} \leq V_{DD} \leq 3.6\text{ V}$ voltage range). They are given only as design guidelines and are not tested.

Typical ADC accuracy values are determined by characterization of a batch of samples from a standard diffusion lot over the full temperature range, where 95% of the devices have an error less than or equal to the value indicated (mean $\pm 2\sigma$).

6.1.3 Typical curves

Unless otherwise specified, all typical curves are given only as design guidelines and are not tested.

6.1.4 Loading capacitor

The loading conditions used for pin parameter measurement are shown in [Figure 11](#).

Figure 11. Pin loading conditions

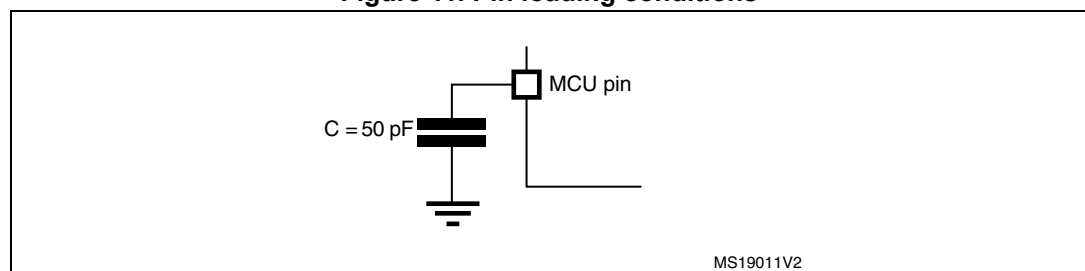

6.1.5 Pin input voltage

The input voltage measurement on a pin of the device is described in [Figure 12](#).

Figure 12. Input voltage measurement

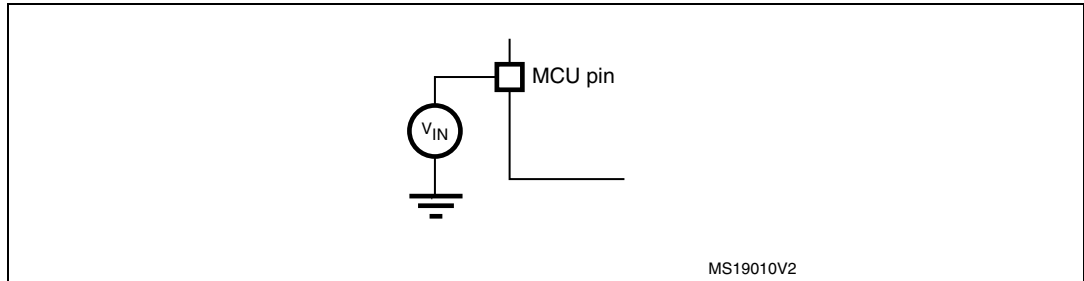

6.1.6 Power supply scheme

Figure 13. Power supply scheme

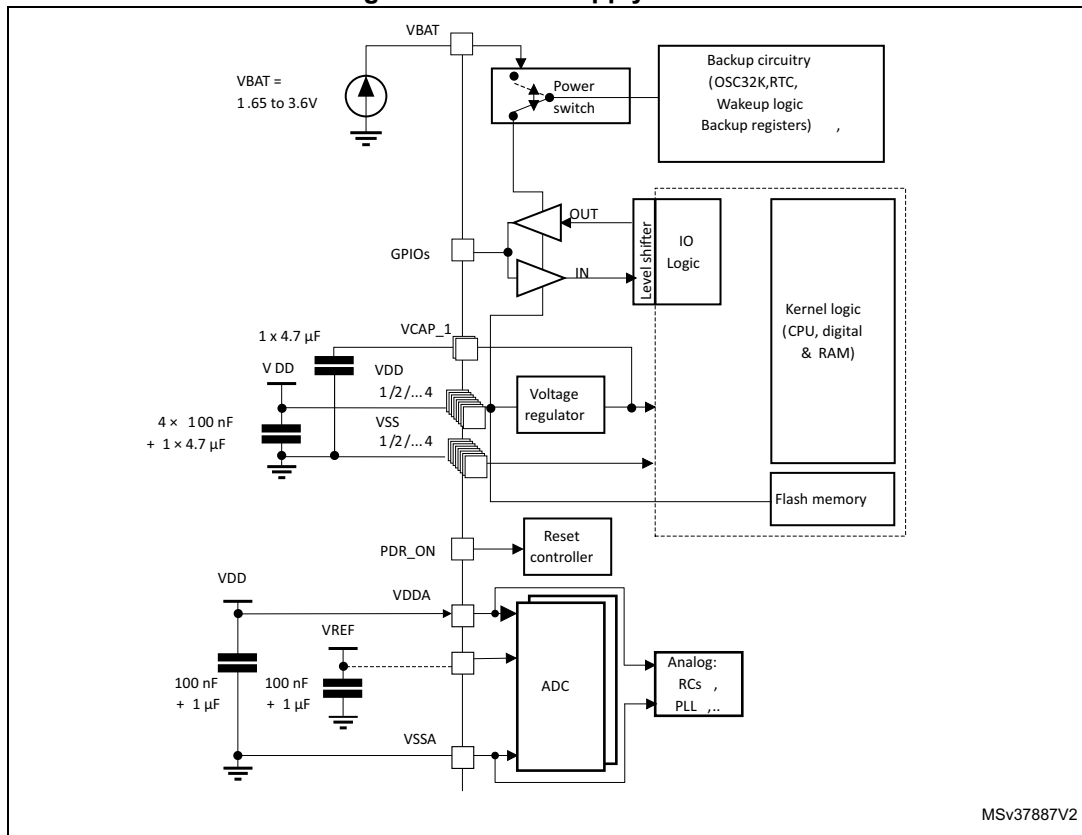

1. To connect PDR_ON pin, refer to [Section 3.14: Power supply supervisor](#).

Caution: Each power supply pair (for example V_{DD}/V_{SS} , V_{DDA}/V_{SSA}) must be decoupled with filtering ceramic capacitors as shown above. These capacitors must be placed as close as possible to, or below, the appropriate pins on the underside of the PCB to ensure good operation of the device. It is not recommended to remove filtering capacitors to reduce PCB size or cost. This might cause incorrect operation of the device.

6.1.7 Current consumption measurement

Figure 14. Current consumption measurement scheme

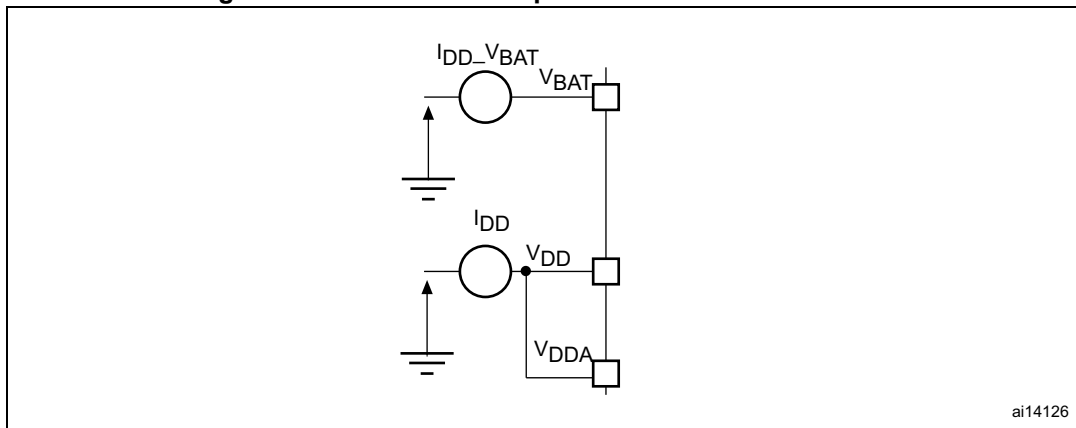

6.2 Absolute maximum ratings

Stresses above the absolute maximum ratings listed in [Table 12: Voltage characteristics](#), [Table 13: Current characteristics](#), and [Table 14: Thermal characteristics](#) may cause permanent damage to the device. These are stress ratings only and functional operation of the device at these conditions is not implied. Exposure to maximum rating conditions for extended periods may affect device reliability.

Table 12. Voltage characteristics

Symbol	Ratings	Min	Max	Unit
$V_{DD}-V_{SS}$	External main supply voltage (including V_{DDA} , V_{DD} and V_{BAT}) ⁽¹⁾	-0.3	4.0	V
V_{IN}	Input voltage on FT and TC pins ⁽²⁾	$V_{SS}-0.3$	$V_{DD}+4.0$	
	Input voltage on any other pin	$V_{SS}-0.3$	4.0	
	Input voltage for BOOT0	V_{SS}	9.0	
$ \Delta V_{DDx} $	Variations between different V_{DD} power pins	-	50	mV
$ V_{SSx}-V_{SS} $	Variations between all the different ground pins including V_{REF-}	-	50	
$V_{ESD(HBM)}$	Electrostatic discharge voltage (human body model)	see Section 6.3.14: Absolute maximum ratings (electrical sensitivity)		V

1. All main power (V_{DD} , V_{DDA}) and ground (V_{SS} , V_{SSA}) pins must always be connected to the external power supply, in the permitted range.
2. V_{IN} maximum value must always be respected. Refer to [Table 13](#) for the values of the maximum allowed injected current.

Table 13. Current characteristics

Symbol	Ratings	Max.	Unit
ΣI_{VDD}	Total current into sum of all V_{DD_x} power lines (source) ⁽¹⁾	160	mA
ΣI_{VSS}	Total current out of sum of all V_{SS_x} ground lines (sink) ⁽¹⁾	-160	
I_{VDD}	Maximum current into each V_{DD_x} power line (source) ⁽¹⁾	100	
I_{VSS}	Maximum current out of each V_{SS_x} ground line (sink) ⁽¹⁾	-100	
I_{IO}	Output current sunk by any I/O and control pin	25	
	Output current sourced by any I/O and control pin	-25	
ΣI_{IO}	Total output current sunk by sum of all I/O and control pins ⁽²⁾	120	
	Total output current sourced by sum of all I/Os and control pins ⁽²⁾	-120	
$I_{INJ(PIN)}$ ⁽³⁾	Injected current on FT and TC pins ⁽⁴⁾	-5/+0	
	Injected current on NRST and B pins ⁽⁴⁾		
$\Sigma I_{INJ(PIN)}$	Total injected current (sum of all I/O and control pins) ⁽⁵⁾	±25	

1. All main power (V_{DD} , V_{DDA}) and ground (V_{SS} , V_{SSA}) pins must always be connected to the external power supply, in the permitted range.
2. This current consumption must be correctly distributed over all I/Os and control pins.
3. Negative injection disturbs the analog performance of the device. See note in [Section 6.3.20: 12-bit ADC characteristics](#).
4. Positive injection is not possible on these I/Os and does not occur for input voltages lower than the specified maximum value.
5. When several inputs are submitted to a current injection, the maximum $\Sigma I_{INJ(PIN)}$ is the absolute sum of the positive and negative injected currents (instantaneous values).

Table 14. Thermal characteristics

Symbol	Ratings	Value	Unit
T_{STG}	Storage temperature range	-65 to +150	°C
T_J	Maximum junction temperature	130	
T_{LEAD}	Maximum lead temperature during soldering (WLCSP36, LQFP48, LQFP64, UFQFPN48, UFBGA64)	see note ⁽¹⁾	

1. Compliant with JEDEC Std J-STD-020D (for small body, Sn-Pb or Pb assembly), the ST ECOPACK® 7191395 specification, and the European directive on Restrictions on Hazardous Substances (ROHS directive 2011/65/EU, July 2011).

6.3 Operating conditions

6.3.1 General operating conditions

Table 15. General operating conditions

Symbol	Parameter	Conditions	Min	Typ	Max	Unit
f _{HCLK}	Internal AHB clock frequency	Power Scale3: Regulator ON, VOS[1:0] bits in PWR_CR register = 0x01	0	-	64	MHz
		Power Scale2: Regulator ON, VOS[1:0] bits in PWR_CR register = 0x10	0	-	84	
		Power Scale1: Regulator ON, VOS[1:0] bits in PWR_CR register = 0x11	0	-	100	
f _{PCLK1}	Internal APB1 clock frequency	-	0	-	50	MHz
f _{PCLK2}	Internal APB2 clock frequency	-	0	-	100	MHz
V _{DD}	Standard operating voltage	-	1.7 ⁽¹⁾	-	3.6	V
V _{DDA} ⁽²⁾⁽³⁾	Analog operating voltage (ADC limited to 1.2 M samples)	Must be the same potential as V _{DD} ⁽⁴⁾	1.7 ⁽¹⁾	-	2.4	V
	Analog operating voltage (ADC limited to 2.4 M samples)		2.4	-	3.6	
V _{BAT}	Backup operating voltage	-	1.65	-	3.6	V
V ₁₂	Regulator ON: 1.2 V internal voltage on VCAP_1 pins	VOS[1:0] bits in PWR_CR register = 0x01 Max frequency 64 MHz	1.08 ⁽⁵⁾	1.14	1.20 ⁽⁵⁾	V
		VOS[1:0] bits in PWR_CR register = 0x10 Max frequency 84 MHz	1.20 ⁽⁵⁾	1.26	1.32 ⁽⁵⁾	
		VOS[1:0] bits in PWR_CR register = 0x11 Max frequency 100 MHz	1.26	1.32	1.38	
V ₁₂	Regulator OFF: 1.2 V external voltage must be supplied on VCAP_1 pins	Max frequency 64 MHz	1.10	1.14	1.20	V
		Max frequency 84 MHz	1.20	1.26	1.32	
		Max frequency 100 MHz	1.26	1.32	1.38	
V _{IN}	Input voltage on RST, FT and TC pins ⁽⁶⁾	2 V ≤ V _{DD} ≤ 3.6 V	-0.3	-	5.5	V
		V _{DD} ≤ 2 V	-0.3	-	5.2	
	Input voltage on BOOT0 pin	-	0	-	9	

Table 15. General operating conditions (continued)

Symbol	Parameter	Conditions	Min	Typ	Max	Unit
P _D	Maximum allowed package power dissipation at T _A = 85 °C (range 6) or 105 °C (range 7) ⁽⁷⁾	LQFP48	-	-	364	mW
		LQFP64	-	-	435	
		UFQFPN48	-	-	606	
		WLCSP36	-	-	328	
		UFBGA64	-	-	253	
	Power dissipation at T _A = 125 °C for range 3 ⁽⁷⁾	LQFP48	-	-	91	
		LQFP64	-	-	108	
		UFQFPN48	-	-	151	
		WLCSP36	-	-	81	
		UFBGA64	-	-	63	
T _A	Ambient temperature for range 6	Maximum power dissipation	-40	-	85	°C
		Low power dissipation ⁽⁸⁾	-40	-	105	
	Ambient temperature for range 7	Maximum power dissipation	-40	-	105	
		Low power dissipation ⁽⁸⁾	-40	-	125	
	Ambient temperature for range 3	Maximum power dissipation	-40	-	110	
		Low power dissipation ⁽⁸⁾	-40	-	130	
T _J	Junction temperature range	Range 6	-40	-	105	
		Range 7	-40	-	125	
		Range 3	-40	-	130	

1. V_{DD}/V_{DDA} minimum value of 1.7 V with the use of an external power supply supervisor (refer to [Section 3.14.2: Internal reset OFF](#)).
2. When the ADC is used, refer to [Table 66: ADC characteristics](#).
3. If VREF+ pin is present, it must respect the following condition: VDDA-VREF+ < 1.2 V.
4. It is recommended to power V_{DD} and V_{DDA} from the same source. A maximum difference of 300 mV between V_{DD} and V_{DDA} can be tolerated during power-up and power-down operation.
5. Guaranteed by test in production.
6. To sustain a voltage higher than VDD+0.3, the internal Pull-up and Pull-Down resistors must be disabled
7. If T_A is lower, higher P_D values are allowed as long as T_J does not exceed T_{Jmax}.
8. In low power dissipation state, T_A can be extended to this range as long as T_J does not exceed T_{Jmax}.

Table 16. Features depending on the operating power supply range

Operating power supply range	ADC operation	Maximum Flash memory access frequency with no wait states ($f_{Flashmax}$)	Maximum Flash memory access frequency with wait states ⁽¹⁾⁽²⁾	I/O operation	Clock output frequency on I/O pins ⁽³⁾	Possible Flash memory operations
$V_{DD} = 1.7$ to 2.1 V ⁽⁴⁾	Conversion time up to 1.2 Msps	16 MHz ⁽⁵⁾	100 MHz with 6 wait states	– No I/O compensation	up to 30 MHz	8-bit erase and program operations only
$V_{DD} = 2.1$ to 2.4 V	Conversion time up to 1.2 Msps	18 MHz	100 MHz with 5 wait states	– No I/O compensation	up to 30 MHz	16-bit erase and program operations
$V_{DD} = 2.4$ to 2.7 V	Conversion time up to 2.4 Msps	24 MHz	100 MHz with 4 wait states	– I/O compensation works	up to 50 MHz	16-bit erase and program operations
$V_{DD} = 2.7$ to 3.6 V	Conversion time up to 2.4 Msps	30 MHz	100 MHz with 3 wait states	– I/O compensation works	– up to 100 MHz when $V_{DD} = 3.0$ to 3.6 V – up to 50 MHz when $V_{DD} = 2.7$ to 3.0 V	32-bit erase and program operations

1. Applicable only when the code is executed from Flash memory. When the code is executed from RAM, no wait state is required.
2. Thanks to the ART accelerator and the 128-bit Flash memory, the number of wait states given here does not impact the execution speed from Flash memory since the ART accelerator allows to achieve a performance equivalent to 0 wait state program execution.
3. Refer to [Table 57: I/O AC characteristics](#) for frequencies vs. external load.
4. V_{DD}/V_{DDA} minimum value of 1.7 V, with the use of an external power supply supervisor (refer to [Section 3.14.2: Internal reset OFF](#)).
5. Prefetch is not available. Refer to AN3430 application note for details on how to adjust performance and power.

6.3.2 VCAP_1 external capacitor

Stabilization for the main regulator is achieved by connecting the external capacitor C_{EXT} to the VCAP_1 pin.

C_{EXT} is specified in [Table 17](#).

Figure 15. External capacitor C_{EXT}

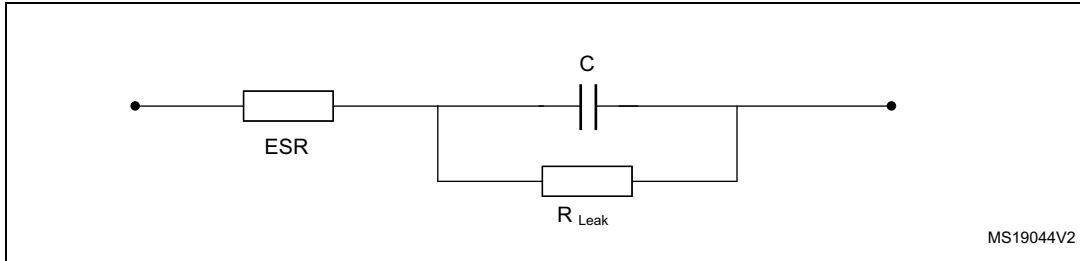

1. Legend: ESR is the equivalent series resistance.

Table 17. VCAP_1 operating conditions

Symbol	Parameter	Conditions
C _{EXT}	Capacitance of external capacitor	4.7 μ F
ESR	ESR of external capacitor	< 1 Ω

6.3.3 Operating conditions at power-up/power-down (regulator ON)

Subject to general operating conditions for T_A .

Table 18. Operating conditions at power-up / power-down (regulator ON)

Symbol	Parameter	Min	Max	Unit
t_{VDD}	V_{DD} rise time rate	20	∞	μ s/V
	V_{DD} fall time rate	20	∞	

6.3.4 Operating conditions at power-up / power-down (regulator OFF)

Subject to general operating conditions for T_A .

Table 19. Operating conditions at power-up / power-down (regulator OFF)⁽¹⁾

Symbol	Parameter	Conditions	Min	Max	Unit
t_{VDD}	V_{DD} rise time rate	Power-up	20	∞	μ s/V
	V_{DD} fall time rate	Power-down	20	∞	
t_{VCAP}	V_{CAP_1} rise time rate	Power-up	20	∞	
	V_{CAP_1} fall time rate	Power-down	20	∞	

1. To reset the internal logic at power-down, a reset must be applied on pin PA0 when V_{DD} reach below 1.08 V.

6.3.5 Embedded reset and power control block characteristics

The parameters given in [Table 20](#) are derived from tests performed under ambient temperature and V_{DD} supply voltage @ 3.3V.

Table 20. Embedded reset and power control block characteristics

Symbol	Parameter	Conditions	Min	Typ	Max	Unit
V_{PVD}	Programmable voltage detector level selection	PLS[2:0]=000 (rising edge)	2.09	2.14	2.19	V
		PLS[2:0]=000 (falling edge)	1.98	2.04	2.08	
		PLS[2:0]=001 (rising edge)	2.23	2.30	2.37	
		PLS[2:0]=001 (falling edge)	2.13	2.19	2.25	
		PLS[2:0]=010 (rising edge)	2.39	2.45	2.51	
		PLS[2:0]=010 (falling edge)	2.29	2.35	2.39	
		PLS[2:0]=011 (rising edge)	2.54	2.60	2.65	
		PLS[2:0]=011 (falling edge)	2.44	2.51	2.56	
		PLS[2:0]=100 (rising edge)	2.70	2.76	2.82	
		PLS[2:0]=100 (falling edge)	2.59	2.66	2.71	
		PLS[2:0]=101 (rising edge)	2.86	2.93	2.99	
		PLS[2:0]=101 (falling edge)	2.65	2.84	3.02	
		PLS[2:0]=110 (rising edge)	2.96	3.03	3.10	
		PLS[2:0]=110 (falling edge)	2.85	2.93	2.99	
		PLS[2:0]=111 (rising edge)	3.07	3.14	3.21	
PLS[2:0]=111 (falling edge)	2.95	3.03	3.09			
$V_{PVDhyst}^{(2)}$	PVD hysteresis	-	-	100	-	mV
$V_{POR/PDR}$	Power-on/power-down reset threshold	Falling edge	1.60 ⁽¹⁾	1.68	1.76	V
		Rising edge	1.64	1.72	1.80	
$V_{PDRhyst}^{(2)}$	PDR hysteresis	-	-	40	-	mV
V_{BOR1}	Brownout level 1 threshold	Falling edge	2.13	2.19	2.24	V
		Rising edge	2.23	2.29	2.33	
V_{BOR2}	Brownout level 2 threshold	Falling edge	2.44	2.50	2.56	
		Rising edge	2.53	2.59	2.63	
V_{BOR3}	Brownout level 3 threshold	Falling edge	2.75	2.83	2.88	
		Rising edge	2.85	2.92	2.97	
$V_{BORhyst}^{(2)}$	BOR hysteresis	-	-	100	-	mV
$T_{RSTTEMPO}^{(2)(3)}$	POR reset timing	-	0.5	1.5	3.0	ms

Table 20. Embedded reset and power control block characteristics (continued)

Symbol	Parameter	Conditions	Min	Typ	Max	Unit
$I_{RUSH}^{(2)}$	In-Rush current on voltage regulator power-on (POR or wakeup from Standby)	-	-	160	200	mA
$E_{RUSH}^{(2)}$	In-Rush energy on voltage regulator power-on (POR or wakeup from Standby)	$V_{DD} = 1.7\text{ V}$, $T_A = 125\text{ °C}$, $I_{RUSH} = 171\text{ mA}$ for $31\text{ }\mu\text{s}$	-	-	5.4	μC

1. The product behavior is guaranteed by design down to the minimum $V_{POR/PDR}$ value.
2. Guaranteed by design.
3. The reset timing is measured from the power-on (POR reset or wakeup from V_{BAT}) to the instant when first instruction is fetched by the user application code.

6.3.6 Supply current characteristics

The current consumption is a function of several parameters and factors such as the operating voltage, ambient temperature, I/O pin loading, device software configuration, operating frequencies, I/O pin switching rate, program location in memory and executed binary code.

The current consumption is measured as described in [Figure 14: Current consumption measurement scheme](#).

All the run-mode current consumption measurements given in this section are performed with a reduced code that gives a consumption equivalent to CoreMark code.

Typical and maximum current consumption

The MCU is placed under the following conditions:

- All I/O pins are in input mode with a static value at VDD or VSS (no load).
- All peripherals are disabled except if it is explicitly mentioned.
- The Flash memory access time is adjusted to both f_{HCLK} frequency and VDD ranges (refer to [Table 16: Features depending on the operating power supply range](#)).
- The voltage scaling is adjusted to f_{HCLK} frequency as follows:
 - Scale 3 for $f_{HCLK} \leq 64\text{ MHz}$
 - Scale 2 for $64\text{ MHz} < f_{HCLK} \leq 84\text{ MHz}$
 - Scale 1 for $84\text{ MHz} < f_{HCLK} \leq 100\text{ MHz}$
- The system clock is HCLK, $f_{PCLK1} = f_{HCLK}/2$, and $f_{PCLK2} = f_{HCLK}$.
- External clock is 4 MHz and PLL is ON except if it is explicitly mentioned.
- The maximum values are obtained for $V_{DD} = 3.6\text{ V}$ and a maximum ambient temperature (T_A), and the typical values for $T_A = 25\text{ °C}$ and $V_{DD} = 3.3\text{ V}$ unless otherwise specified.

Table 21. Typical and maximum current consumption, code with data processing (ART accelerator disabled) running from SRAM - V_{DD} = 1.7 V

Symbol	Parameter	Conditions	f _{HCLK} (MHz)	Voltage scale	PLL VCO (MHz) (1)	Typ	Max ⁽²⁾					Unit
						T _A = 25 °C	T _A = 25 °C	T _A = 85 °C	T _A = 105 °C	T _A = 125 °C		
I _{DD}	Supply current in Run mode	External clock, all peripherals enabled ⁽³⁾⁽⁴⁾	100	S1	200	17.4	18.3 ⁽⁵⁾	19.1	19.4	20.2 ⁽⁵⁾	mA	
			84	S2	168	14.1	14.8 ⁽⁵⁾	15.4	15.8	16.6 ⁽⁵⁾		
			64	S3	128	9.8	10.3 ⁽⁵⁾	10.7	11.0	11.7 ⁽⁵⁾		
			50	S3	100	7.7	8.1	8.5	8.8	9.5		
			25	S3	100	4.1	4.4	4.7	5.0	5.7		
			20	S3	160	3.5	3.8	4.1	4.4	5.1		
		HSI, PLL off, all peripherals enabled ⁽³⁾⁽⁴⁾	16	S3	off	2.5	2.6	2.9	3.2	4.0		
			1	S3	off	0.4	0.5	0.8	1.2	2.0		
		External clock, all peripherals disabled ⁽³⁾	100	S1	200	11.8	12.5	12.9	13.3	14.1		
			84	S2	168	9.6	10.1	10.4	10.8	11.6		
			64	S3	128	6.7	7.2	7.4	7.7	8.4		
			50	S3	100	5.3	5.6	5.9	6.2	6.9		
			25	S3	100	2.9	3.1	3.3	3.7	4.4		
			20	S3	160	2.5	2.7	2.9	3.2	3.9		
		HSI, PLL off, all peripherals disabled ⁽³⁾	16	S3	off	1.7	1.9	2.1	2.4	3.2		
			1	S3	off	0.3	0.4	0.7	1.1	1.9		

1. Refer to [Table 44](#) and RM0401 for the possible PLL VCO setting
2. Guaranteed by characterization, unless otherwise specified
3. When the ADC is ON (ADON bit set in ADC_CR2), an additional power consumption of 1.6 mA must be added.
4. Add an additional power consumption of 1.6 mA per ADC for the analog part. In applications, this consumption occurs only while the ADC is ON (ADON bit is set in the ADC_CR2 register)
5. Guaranteed by tests in production.

Table 22. Typical and maximum current consumption, code with data processing (ART accelerator disabled) running from SRAM - V_{DD} = 3.6 V

Symbol	Parameter	Conditions	f _{HCLK} (MHz)	Voltage scale	PLL VCO (MHz) (1)	Typ	Max ⁽²⁾					Unit
							T _A = 25 °C	T _A = 25 °C	T _A = 85 °C	T _A = 105 °C	T _A = 125 °C	
I _{DD}	Supply current in Run mode	External clock, all peripherals enabled ⁽³⁾⁽⁴⁾	100	S1	200	17.7	19.1 ⁽⁵⁾	19.3	19.7	20.5 ⁽⁵⁾	mA	
			84	S2	168	14.4	15.3 ⁽⁵⁾	15.7	16.0	16.8 ⁽⁵⁾		
			64	S3	128	10.1	10.6 ⁽⁵⁾	11.0	11.3	12.0 ⁽⁵⁾		
			50	S3	100	8.0	8.4	8.8	9.1	9.8		
			25	S3	100	4.4	4.7	4.9	5.2	5.9		
			20	S3	160	3.8	4.1	4.3	4.6	5.3		
		HSI, PLL off, all peripherals enabled ⁽³⁾⁽⁴⁾	16	S3	off	2.5	2.6	2.9	3.2	4.0		
			1	S3	off	0.4	0.5	0.8	1.2	2.0		
		External clock, all peripherals disabled ⁽³⁾	100	S1	200	12.1	13.1 ⁽⁵⁾	13.1	13.5	14.3 ⁽⁵⁾		
			84	S2	168	9.8	10.6 ⁽⁵⁾	10.7	11.0	11.8 ⁽⁵⁾		
			64	S3	128	7.0	7.4 ⁽⁵⁾	7.6	7.9	8.6 ⁽⁵⁾		
			50	S3	100	5.6	5.9	6.1	6.4	7.2		
			25	S3	100	3.1	3.3	3.5	3.9	4.8		
			20	S3	160	2.8	3.0	3.2	3.5	4.4		
		HSI, PLL off, all peripherals disabled ⁽³⁾	16	S3	off	1.7	1.8	2.1	2.4	3.3		
			1	S3	off	0.4	0.4	0.7	1.1	1.8		

1. Refer to [Table 44](#) and RM0401 for the possible PLL VCO setting
2. Guaranteed by characterization.
3. When the ADC is ON (ADON bit set in ADC_CR2), an additional power consumption of 1.6 mA must be added.
4. Add an additional power consumption of 1.6 mA per ADC for the analog part. In applications, this consumption occurs only while the ADC is ON (ADON bit is set in the ADC_CR2 register)
5. Guaranteed by tests in production.

Table 23. Typical and maximum current consumption in run mode, code with data processing (ART accelerator enabled except prefetch) running from Flash memory- $V_{DD} = 1.7\text{ V}$

Symbol	Parameter	Conditions	f_{HCLK} (MHz)	Voltage scale	PLL VCO (MHz) (1)	Typ	Max ⁽²⁾					Unit
						$T_A = 25\text{ °C}$	$T_A = 25\text{ °C}$	$T_A = 85\text{ °C}$	$T_A = 105\text{ °C}$	$T_A = 125\text{ °C}$		
I_{DD}	Supply current in Run mode	External clock, all peripherals enabled ⁽³⁾⁽⁴⁾	100	S1	200	15.7	16.5	16.5	16.9	17.8	mA	
			84	S2	168	12.7	13.3	13.4	13.8	14.6		
			64	S3	128	8.8	9.3	9.4	9.7	10.6		
			50	S3	100	7.0	7.4	7.5	7.8	8.6		
			25	S3	100	3.9	4.1	4.3	4.7	5.6		
			20	S3	160	3.4	3.6	3.8	4.2	5.1		
		HSI, PLL OFF, all peripherals enabled ⁽³⁾⁽⁴⁾	16	S3	off	2.4	2.5	2.8	3.2	4.1		
			1	S3	off	0.6	0.7	1.0	1.4	2.3		
		External clock, all peripherals disabled ⁽³⁾	100	S1	200	10.1	10.7	10.8	11.2	12.0		
			84	S2	168	8.2	8.6	8.7	9.1	10.0		
			64	S3	128	5.7	6.1	6.2	6.6	7.4		
			50	S3	100	4.6	4.9	5.0	5.4	6.3		
			25	S3	100	2.6	2.8	3.0	3.4	4.3		
			20	S3	160	2.4	2.5	2.8	3.1	4.0		
		HSI, PLL OFF, all peripherals disabled ⁽³⁾	16	S3	off	1.7	1.8	2.1	2.4	3.3		
			1	S3	off	0.6	0.6	1.0	1.4	2.2		

1. Refer to [Table 44](#) and RM0401 for the possible PLL VCO setting
2. Guaranteed by characterization, unless otherwise specified.
3. When the ADC is ON (ADON bit set in ADC_CR2), an additional power consumption of 1.6 mA must be added.
4. Add an additional power consumption of 1.6 mA per ADC for the analog part. In applications, this consumption occurs only while the ADC is ON (ADON bit is set in the ADC_CR2 register)

Table 24. Typical and maximum current consumption in run mode, code with data processing (ART accelerator enabled except prefetch) running from Flash memory - V_{DD} = 3.6 V

Symbol	Parameter	Conditions	f _{HCLK} (MHz)	Voltage scale	PLL VCO (MHz) ⁽¹⁾	Typ	Max ⁽²⁾					Unit
						T _A = 25 °C	T _A = 25 °C	T _A = 85 °C	T _A = 105 °C	T _A = 125 °C		
I _{DD}	Supply current in Run mode	External clock, all peripherals enabled ⁽³⁾⁽⁴⁾	100	S1	200	16.3	17.3 ⁽⁵⁾	17.1	17.5	18.4 ⁽⁵⁾	mA	
			84	S2	168	13.2	14.1	14.0	14.3	15.2		
			64	S3	128	9.3	10.0	9.9	10.2	11.1		
			50	S3	100	7.4	8.0	8.0	8.3	9.2		
			25	S3	100	4.2	4.7	4.8	5.0	5.9		
			20	S3	160	3.7	4.2	4.3	4.6	5.5		
		HSI, PLL OFF, all peripherals enabled ⁽³⁾⁽⁴⁾	16	S3	off	2.4	2.8	3.0	3.4	4.3		
			1	S3	off	0.6	1.0	1.2	1.5	2.4		
		External clock, all peripherals disabled ⁽³⁾	100	S1	200	10.6	11.4 ⁽⁵⁾	11.4	11.7	12.6 ⁽⁵⁾		
			84	S2	168	8.7	9.4	9.3	9.7	10.6		
			64	S3	128	6.2	6.8	6.8	7.1	7.9		
			50	S3	100	5.0	5.5	5.5	5.8	6.8		
			25	S3	100	2.9	3.4	3.5	3.8	4.7		
			20	S3	160	2.7	3.1	3.2	3.5	4.4		
		HSI, PLL OFF, all peripherals disabled ⁽³⁾	16	S3	off	1.7	2.1	2.3	2.6	3.5		
			1	S3	off	0.6	0.9	1.1	1.5	2.4		

1. Refer to [Table 44](#) and RM0401 for the possible PLL VCO setting
2. Guaranteed by characterization, unless otherwise specified.
3. When the ADC is ON (ADON bit set in ADC_CR2), an additional power consumption of 1.6 mA must be added.
4. Add an additional power consumption of 1.6 mA per ADC for the analog part. In applications, this consumption occurs only while the ADC is ON (ADON bit is set in the ADC_CR2 register)
5. Guaranteed by tests in production.

Table 25. Typical and maximum current consumption in run mode, code with data processing (ART accelerator disabled) running from Flash memory - V_{DD} = 3.6 V

Symbol	Parameter	Conditions	f _{HCLK} (MHz)	Voltage scale	PLL VCO (MHz) ⁽¹⁾	Typ	Max ⁽²⁾					Unit
						T _A = 25 °C	T _A = 25 °C	T _A = 85 °C	T _A = 105 °C	T _A = 125 °C		
I _{DD}	Supply current in Run mode	External clock, all peripherals enabled ⁽³⁾⁽⁴⁾	100	S1	200	24.7	26.3	26.5	27.0	28.0	mA	
			84	S2	168	21.6	23.0	23.2	23.7	24.7		
			64	S3	128	15.9	17.0	17.1	17.6	18.6		
			50	S3	100	13.1	14.2	14.3	14.7	15.7		
			25	S3	100	7.5	8.2	8.3	8.7	9.7		
			20	S3	160	6.5	7.1	7.2	7.5	8.5		
		HSI, PLL OFF, all peripherals enabled ⁽³⁾⁽⁴⁾	16	S3	off	4.7	5.3	5.5	5.9	6.9		
			1	S3	off	0.8	1.2	1.6	1.9	2.9		
		External clock, all peripherals disabled ⁽³⁾	100	S1	200	19.1	20.5	20.7	21.3	22.3		
			84	S2	168	17.1	18.3	18.6	19.1	20.1		
			64	S3	128	12.8	13.8	14.0	14.5	15.5		
			50	S3	100	10.7	11.7	11.8	12.2	13.2		
			25	S3	100	6.3	7.0	7.1	7.4	8.3		
			20	S3	160	5.4	6.0	6.2	6.5	7.4		
		HSI, PLL OFF, all peripherals disabled ⁽³⁾	16	S3	off	4.0	4.5	5.0	5.1	6.0		
			1	S3	off	0.8	1.1	1.5	1.8	2.7		

1. Refer to [Table 44](#) and RM0401 for the possible PLL VCO setting
2. Guaranteed by characterization, unless otherwise specified.
3. When the ADC is ON (ADON bit set in ADC_CR2), an additional power consumption of 1.6 mA must be added.
4. Add an additional power consumption of 1.6 mA per ADC for the analog part. In applications, this consumption occurs only while the ADC is ON (ADON bit is set in the ADC_CR2 register)

Table 26. Typical and maximum current consumption in run mode, code with data processing (ART accelerator disabled) running from Flash memory - V_{DD} = 1.7 V

Symbol	Parameter	Conditions	f _{HCLK} (MHz)	Voltage scale	PLL VCO (MHz) (1)	Typ	Max ⁽²⁾					Unit
							T _A = 25 °C	T _A = 25 °C	T _A = 85 °C	T _A = 105 °C	T _A = 125 °C	
I _{DD}	Supply current in Run mode	External clock, all peripherals enabled ⁽³⁾⁽⁴⁾	100	S1	200	24.2	26.2	25.7	26.5	27.6	mA	
			84	S2	168	20.0	21.8	21.4	22.1	23.1		
			64	S3	128	15.8	17.2	17.0	17.7	18.7		
			50	S3	100	13.3	16.5	14.4	15.0	16.0		
			25	S3	100	7.5	9.5	8.3	8.8	9.8		
			20	S3	160	6.7	8.2	7.3	7.7	8.6		
		HSI, PLL OFF, all peripherals enabled ⁽³⁾⁽⁴⁾	16	S3	off	5.1	6.4	5.7	6.2	7.1		
			1	S3	off	0.8	1.0	1.3	1.7	2.6		
		External clock, all peripherals disabled ⁽³⁾	100	S1	200	18.6	23.0	23.4	23.9	24.9		
			84	S2	168	15.5	19.3	19.9	20.4	21.4		
			64	S3	128	12.7	16.1	16.7	17.0	18.0		
			50	S3	100	10.9	13.9	14.3	14.7	15.7		
			25	S3	100	6.3	8.1	8.4	8.7	9.7		
			20	S3	160	5.6	7.2	7.3	7.6	8.4		
		HSI, PLL OFF, all peripherals disabled ⁽³⁾	16	S3	off	4.3	5.5	5.8	6.2	7.1		
			1	S3	off	0.8	1.0	1.3	1.6	2.5		

1. Refer to [Table 44](#) and RM0401 for the possible PLL VCO setting
2. Guaranteed by characterization, unless otherwise specified.
3. When the ADC is ON (ADON bit set in ADC_CR2), an additional power consumption of 1.6 mA must be added.
4. Add an additional power consumption of 1.6 mA per ADC for the analog part. In applications, this consumption occurs only while the ADC is ON (ADON bit is set in the ADC_CR2 register)

Table 27. Typical and maximum current consumption in run mode, code with data processing (ART accelerator enabled with prefetch) running from Flash memory - V_{DD} = 3.6 V

Symbol	Parameter	Conditions	f _{HCLK} (MHz)	Voltage scale	PLL VCO (MHz) ⁽¹⁾	Typ	Max ⁽²⁾					Unit
						T _A = 25 °C	T _A = 25 °C	T _A = 85 °C	T _A = 105 °C	T _A = 125 °C		
I _{DD}	Supply current in Run mode	External clock, all peripherals enabled ⁽³⁾⁽⁴⁾	100	S1	200	27.1	28.9	28.9	29.5	30.5	mA	
			84	S2	168	23.2	24.8	24.9	25.5	26.5		
			64	S3	128	17.0	18.3	18.4	18.8	19.8		
			50	S3	100	13.6	14.7	14.7	15.2	16.2		
			25	S3	100	7.5	8.2	8.3	8.7	9.7		
			20	S3	160	6.5	7.1	7.2	7.5	8.5		
		HSI, PLL OFF, all peripherals enabled ⁽³⁾⁽⁴⁾	16	S3	off	4.7	5.3	5.5	5.9	6.9		
			1	S3	off	0.8	1.2	1.4	1.8	2.8		
		External clock, all peripherals disabled ⁽³⁾	100	S1	200	21.5	23.0	23.2	23.8	24.8		
			84	S2	168	18.7	20.0	20.3	20.8	21.8		
			64	S3	128	14.0	15.1	15.2	15.7	16.7		
			50	S3	100	11.2	12.2	12.3	12.7	13.7		
			25	S3	100	6.3	7.0	7.1	7.4	8.4		
			20	S3	160	5.4	6.0	6.2	6.5	7.5		
		HSI, PLL OFF, all peripherals disabled ⁽³⁾	16	S3	off	4.0	4.5	4.8	5.1	6.1		
			1	S3	off	0.8	1.1	1.4	1.7	2.7		

1. Refer to [Table 44](#) and RM0401 for the possible PLL VCO setting
2. Guaranteed by characterization, unless otherwise specified.
3. When the ADC is ON (ADON bit set in ADC_CR2), an additional power consumption of 1.6 mA must be added.
4. Add an additional power consumption of 1.6 mA per ADC for the analog part. In applications, this consumption occurs only while the ADC is ON (ADON bit is set in the ADC_CR2 register)

Table 28. Typical and maximum current consumption in Sleep mode - V_{DD} = 3.6 V

Symbol	Parameter	Conditions	f _{HCLK} (MHz)	Voltage scale	PLL VCO (MHz) (1)	Typ	Max ⁽²⁾					Unit
						T _A = 25 °C	T _A = 25 °C	T _A = 85 °C	T _A = 105 °C	T _A = 125 °C		
I _{DD}	Supply current in Sleep mode	All peripherals enabled ⁽³⁾⁽⁴⁾ , External clock, PLL ON, Flash memory in Deep power down mode	100	S1	200	8.0	8.2 ⁽⁵⁾	9.0	9.4	10.2 ⁽⁵⁾	mA	
			84	S2	168	6.5	6.7	7.4	7.7	8.5		
			64	S3	128	4.6	4.7	5.2	5.5	6.3		
			50	S3	100	3.7	3.9	4.3	4.6	5.4		
			25	S3	100	2.2	2.3	2.6	2.9	3.8		
			20	S3	160	2.1	2.2	2.5	2.8	3.6		
		All peripherals enabled ⁽³⁾⁽⁴⁾ , HSI, PLL OFF, Flash memory in Deep power down mode	16	S3	off	1.1	1.2	1.5	1.9	2.7		
			1	S3	off	0.3	0.4	0.7	1.1	1.9		
		All peripherals enabled ⁽³⁾⁽⁴⁾ , External clock, PLL ON, Flash memory ON	100	S1	200	8.4	8.7	9.5	9.9	10.7		
			84	S2	168	6.9	7.1	7.7	8.1	8.9		
			64	S3	128	4.9	5.1	5.5	5.9	6.7		
			50	S3	100	4.0	4.2	4.6	4.9	5.7		
			25	S3	100	2.5	2.6	2.9	3.2	4.0		
			20	S3	160	2.4	2.5	2.7	3.1	3.9		
		All peripherals enabled ⁽³⁾ , HSI, PLL OFF, Flash memory ON	16	S3	off	1.4	1.4	1.8	2.2	3.0		
			1	S3	off	0.6	0.6	1.0	1.3	2.0		

Table 28. Typical and maximum current consumption in Sleep mode - V_{DD} = 3.6 V (continued)

Symbol	Parameter	Conditions	f _{HCLK} (MHz)	Voltage scale	PLL VCO (MHz) (1)	Typ	Max ⁽²⁾					Unit
							T _A = 25 °C	T _A = 25 °C	T _A = 85 °C	T _A = 105 °C	T _A = 125 °C	
I _{DD} (continued)	Supply current in Sleep mode (continued)	All peripherals disabled, External clock, PLL ON, Flash memory in Deep power down mode	100	S1	200	2.2	2.3 ⁽⁵⁾	2.6	3.0	3.8 ⁽⁵⁾	mA	
			84	S2	168	1.8	1.9	2.2	2.6	3.4		
			64	S3	128	1.4	1.5	1.8	2.1	2.9		
			50	S3	100	1.2	1.3	1.6	1.9	2.7		
			25	S3	100	0.9	1.0	1.3	1.7	2.5		
			20	S3	160	1.0	1.2	1.4	1.7	2.5		
		All peripherals disabled, HSI, PLL OFF, Flash memory in Deep power down mode	16	S3	off	0.3	0.4	0.7	1.1	1.9		
			1	S3	off	0.3	0.3	0.7	1.0	1.8		
		All peripherals disabled, External clock, PLL ON, Flash memory ON	100	S1	200	2.6	2.7	3.0	3.4	4.2		
			84	S2	168	2.2	2.3	2.6	3.0	3.8		
			64	S3	128	1.8	1.9	2.1	2.5	3.3		
			50	S3	100	1.5	1.6	1.9	2.2	3.1		
			25	S3	100	1.2	1.4	1.6	2.0	2.8		
			20	S3	160	1.3	1.4	1.7	2.0	2.8		
		All peripherals disabled, HSI, PLL OFF, Flash memory in Deep power down mode	16	S3	off	0.6	0.6	1.0	1.3	2.0		
			1	S3	off	0.5	0.6	0.9	1.3	2.0		

1. Refer to [Table 44](#) and RM0401 for the possible PLL VCO setting
2. Guaranteed by characterization, unless otherwise specified.
3. When the ADC is ON (ADON bit set in ADC_CR2), an additional power consumption of 1.6 mA must be added.
4. Add an additional power consumption of 1.6 mA per ADC for the analog part. In applications, this consumption occurs only while the ADC is ON (ADON bit is set in the ADC_CR2 register)
5. Guaranteed by tests in production.

Table 29. Typical and maximum current consumption in Sleep mode - V_{DD} = 1.7 V

Symbol	Parameter	Conditions	f _{HCLK} (MHz)	Voltage scale	PLL VCO (MHz) ⁽¹⁾	Typ	Max ⁽²⁾					Unit
						T _A = 25 °C	T _A = 25 °C	T _A = 85 °C	T _A = 105 °C	T _A = 125 °C		
I _{DD}	Supply current in Sleep mode	All peripherals enabled ⁽³⁾ ⁽⁴⁾ , External clock, PLL ON, Flash memory in Deep power down mode	100	S1	200	7.7	7,9	8,8	9,2	10.0	mA	
			84	S2	168	6.2	6,4	7,1	7,5	8.3		
			64	S3	128	4.3	4,5	5,0	5,3	6.1		
			50	S3	100	3.4	3,6	4,0	4,4	5.2		
			25	S3	100	2.0	2,1	2,4	2,7	3.5		
			20	S3	160	1.8	1,9	2,3	2,6	3.4		
		All peripherals enabled ⁽³⁾⁽⁴⁾ , HSI, PLL OFF, Flash memory in Deep power down mode	16	S3	off	1.1	1,2	1,5	1,9	2.7		
			1	S3	off	0.3	0,4	0,7	1,0	1.8		
		All peripherals enabled ⁽³⁾⁽⁴⁾ , External clock, PLL ON, Flash memory ON	100	S1	200	8.1	8,4	9,3	9,7	10.5		
			84	S2	168	6.6	6,8	7,5	7,9	8.7		
			64	S3	128	4.7	4,8	5,4	5,7	6.5		
			50	S3	100	3.8	3,9	4,4	4,7	5.5		
			25	S3	100	2.3	2,4	2,7	3,1	3.9		
			20	S3	160	2.1	2,2	2,6	2,9	3.7		
		All peripherals enabled ⁽³⁾⁽⁴⁾ , HSI, PLL OFF, Flash memory ON	16	S3	off	1.4	1,5	1,8	2,2	3.0		
			1	S3	off	0.5	0,6	1,0	1,3	2.0		

Table 29. Typical and maximum current consumption in Sleep mode - V_{DD} = 1.7 V (continued)

Symbol	Parameter	Conditions	f _{HCLK} (MHz)	Voltage scale	PLL VCO (MHz) ⁽¹⁾	Typ	Max ⁽²⁾					Unit
						T _A = 25 °C	T _A = 25 °C	T _A = 85 °C	T _A = 105 °C	T _A = 125 °C		
I _{DD} (continued)	Supply current in Sleep mode (continued)	All peripherals disabled, External clock, PLL ON, Flash memory in Deep power down mode	100	S1	200	1.9	2,0	2,4	2,7	3,5	mA	
			84	S2	168	1.6	1,7	2,0	2,4	3,2		
			64	S3	128	1.1	1,2	1,5	1,9	2,7		
			50	S3	100	0.9	1,0	1,3	1,7	2,5		
			25	S3	100	0.7	0,8	1,1	1,4	2,2		
			20	S3	160	0.8	0,8	1,2	1,5	2,3		
		All peripherals disabled, HSI, PLL OFF, Flash memory in Deep power down mode	16	S3	off	0.3	0,4	0,7	1,0	1,8		
			1	S3	off	0.2	0,3	0,6	1,0	1,8		
		All peripherals disabled, External clock, PLL ON, Flash memory ON	100	S1	200	2.3	2,4	2,9	3,3	4,0		
			84	S2	168	2.0	2,1	2,4	2,8	3,6		
			64	S3	128	1.5	1,6	1,9	2,3	3,1		
			50	S3	100	1.3	1,4	1,7	2,0	2,8		
			25	S3	100	1.0	1,1	1,4	1,7	2,5		
			20	S3	160	1.0	1,2	1,5	1,8	2,6		
		All peripherals disabled, HSI, PLL OFF, Flash memory in Deep power down mode	16	S3	off	0.6	0,6	1,0	1,4	2,1		
			1	S3	off	0.5	0,6	0,9	1,3	2,0		

1. Refer to [Table 44](#) and RM0401 for the possible PLL VCO setting
2. Guaranteed by characterization, unless otherwise specified.
3. When the ADC is ON (ADON bit set in ADC_CR2), an additional power consumption of 1.6 mA must be added.
4. Add an additional power consumption of 1.6 mA per ADC for the analog part. In applications, this consumption occurs only while the ADC is ON (ADON bit is set in the ADC_CR2 register)

Table 30. Typical and maximum current consumptions in Stop mode - V_{DD} = 1.7 V

Symbol	Conditions		Typ	Max					Unit
			T _A = 25 °C	T _A = 25 °C ⁽¹⁾	T _A = 85 °C	T _A = 105 °C ⁽¹⁾	T _A = 125 °C ⁽¹⁾		
I _{DD_STOP}	Flash in Stop mode, all oscillators OFF, no independent watchdog	Main regulator usage	105.6	117.1	385.1	665.7	1270.0	µA	
		Low power regulator usage	39.5	48.7	287.5	548.4	1070.0		
	Flash in Deep power down mode, all oscillators OFF, no independent watchdog	Main regulator usage	77.8	87.5	351.3	630.1	1222.0		
		Low power regulator usage	11.0	20.0	254.2	512.0	1006.0		
		Low power low voltage regulator usage	6.1	13.6	217.0	442.5	941.0		

1. Guaranteed by characterization.

Table 31. Typical and maximum current consumption in Stop mode - V_{DD}=3.6 V

Symbol	Conditions		Typ	Max					Unit
			T _A = 25 °C	T _A = 25 °C ⁽¹⁾	T _A = 85 °C	T _A = 105 °C ⁽¹⁾	T _A = 125 °C ⁽¹⁾		
I _{DD_STOP}	Flash in Stop mode, all oscillators OFF, no independent watchdog	Main regulator usage	108.6	126 ⁽²⁾	392.8	675.4	1280.0 ⁽²⁾	µA	
		Low power regulator usage	41.03	50.31 ⁽²⁾	290.9	554.2	1077.0 ⁽²⁾		
	Flash in Deep power down mode, all oscillators OFF, no independent watchdog	Main regulator usage	80.32	94.0 ⁽²⁾	357.0	639.5	1232.0 ⁽²⁾		
		Low power regulator usage	12.41	21.5 ⁽²⁾	258.1	518.1	1010.0 ⁽²⁾		
		Low power low voltage regulator usage	7.53	15.2 ⁽²⁾	221.6	449.2	947.0 ⁽²⁾		

1. Guaranteed by characterization.

2. Guaranteed by tests in production.

Table 32. Typical and maximum current consumption in Standby mode - V_{DD}= 1.7 V

Symbol	Parameter	Conditions	Typ	Max					Unit
			T _A = 25 °C	T _A = 25 °C ⁽¹⁾	T _A = 85 °C	T _A = 105 °C ⁽¹⁾	T _A = 125 °C ⁽¹⁾		
I _{DD_STBY}	Supply current in Standby mode	Low-speed oscillator (LSE) and RTC ON	2.1	2.9	6.5	18.2	60.0	µA	
		RTC and LSE OFF	1.2	1.9	5.5	17.1	59.0		

1. Guaranteed by characterization, unless otherwise specified.

Table 33. Typical and maximum current consumption in Standby mode - V_{DD}= 3.6 V

Symbol	Parameter	Conditions	Typ	Max					Unit
			T _A = 25 °C	T _A = 25 °C ⁽¹⁾	T _A = 85 °C	T _A = 105 °C ⁽¹⁾	T _A = 125 °C ⁽¹⁾		
I _{DD_STBY}	Supply current in Standby mode	Low-speed oscillator (LSE) and RTC ON	3.4	4.3	8.9	22.8	65.0	µA	
		RTC and LSE OFF	2.5	3.3 ⁽²⁾	7.8	21.6	64.0 ⁽²⁾		

1. Guaranteed by characterization, unless otherwise specified.
2. Guaranteed by tests in production.

Table 34. Typical and maximum current consumptions in V_{BAT} mode (LSE and RTC ON, LSE low- drive mode)

Symbol	Parameter	Conditions ⁽¹⁾	Typ			Max ⁽²⁾			Unit
			T _A = 25 °C			T _A = 85 °C	T _A = 105 °C	T _A = 125 °C	
			V _{BAT} = 1.7 V	V _{BAT} = 2.4 V	V _{BAT} = 3.3 V	V _{BAT} = 3.6 V			
I _{DD_VBAT}	Backup domain supply current	Low-speed oscillator (LSE in low-drive mode) and RTC ON	0.7	0.8	1.1	2.8	4.2	5.6	µA
		Low-speed oscillator (LSE in high-drive mode) and RTC ON	1.4	1.6	1.9	4.2	7.0	8.6	
		RTC and LSE OFF	0.1	0.1	0.1	2.0	4.0	5.8	

1. Crystal used: Abracon ABS07-120-32.768 kHz-T with a C_L of 6 pF for typical values.
2. Guaranteed by characterization.

Figure 16. Typical V_{BAT} current consumption (LSE and RTC ON/LSE oscillator in “low power” mode selection)

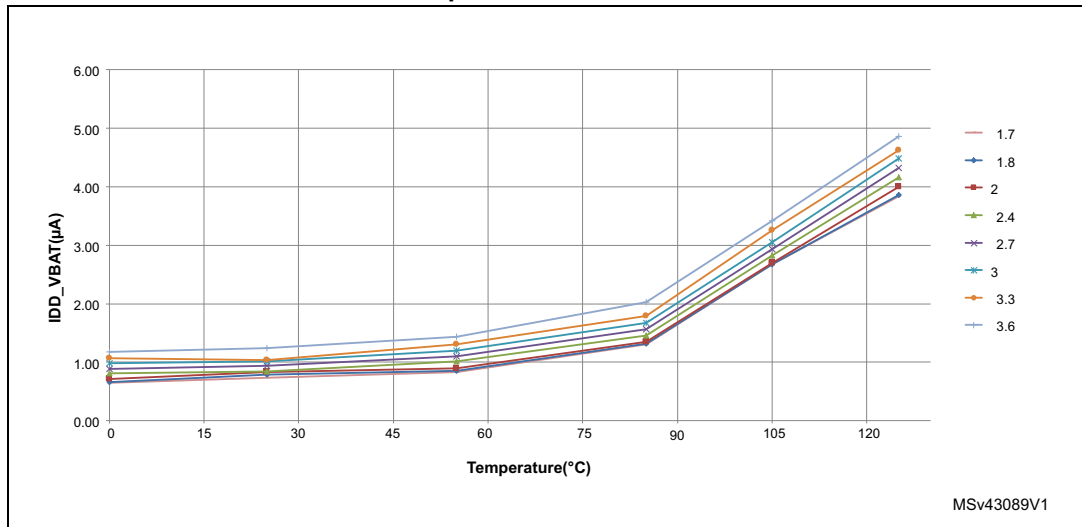
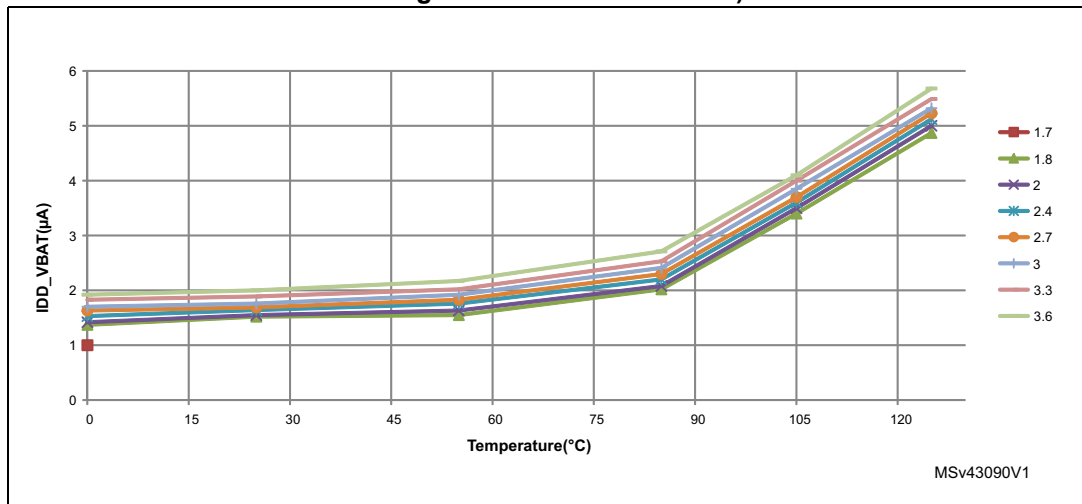

Figure 17. Typical V_{BAT} current consumption (LSE and RTC ON/LSE oscillator in “high-drive” mode selection)



I/O system current consumption

The current consumption of the I/O system has two components: static and dynamic.

I/O static current consumption

All the I/Os used as inputs with pull-up generate current consumption when the pin is externally held low. The value of this current consumption can be simply computed by using the pull-up/pull-down resistors values given in [Table 55: I/O static characteristics](#).

For the output pins, any external pull-down or external load must also be considered to estimate the current consumption.

Additional I/O current consumption is due to I/Os configured as inputs if an intermediate voltage level is externally applied. This current consumption is caused by the input Schmitt

trigger circuits used to discriminate the input value. Unless this specific configuration is required by the application, this supply current consumption can be avoided by configuring these I/Os in analog mode. This is notably the case of ADC input pins which should be configured as analog inputs.

Caution: Any floating input pin can also settle to an intermediate voltage level or switch inadvertently, as a result of external electromagnetic noise. To avoid current consumption related to floating pins, they must either be configured in analog mode, or forced internally to a definite digital value. This can be done either by using pull-up/down resistors or by configuring the pins in output mode.

I/O dynamic current consumption

In addition to the internal peripheral current consumption (see [Table 36: Peripheral current consumption](#)), the I/Os used by an application also contribute to the current consumption. When an I/O pin switches, it uses the current from the MCU supply voltage to supply the I/O pin circuitry and to charge/discharge the capacitive load (internal or external) connected to the pin:

$$I_{SW} = V_{DD} \times f_{SW} \times C$$

where

I_{SW} is the current sunk by a switching I/O to charge/discharge the capacitive load

V_{DD} is the MCU supply voltage

f_{SW} is the I/O switching frequency

C is the total capacitance seen by the I/O pin: $C = C_{INT} + C_{EXT}$

The test pin is configured in push-pull output mode and is toggled by software at a fixed frequency.

Table 35. Switching output I/O current consumption

Symbol	Parameter	Conditions ⁽¹⁾	I/O toggling frequency (f _{sw})	Typ	Unit
IDDIO	I/O switching current	V _{DD} = 3.3 V C = C _{INT}	2 MHz	0.05	mA
			8 MHz	0.15	
			25 MHz	0.45	
			50 MHz	0.85	
			60 MHz	1.00	
			84 MHz	1.40	
			90 MHz	1.67	
		V _{DD} = 3.3 V C _{EXT} = 0 pF C = C _{INT} + C _{EXT} + C _S	2 MHz	0.10	
			8 MHz	0.35	
			25 MHz	1.05	
			50 MHz	2.20	
			60 MHz	2.40	
			84 MHz	3.55	
			90 MHz	4.23	
		V _{DD} = 3.3 V C _{EXT} = 10 pF C = C _{INT} + C _{EXT} + C _S	2 MHz	0.20	
			8 MHz	0.65	
			25 MHz	1.85	
			50 MHz	2.45	
			60 MHz	4.70	
			84 MHz	8.80	
		V _{DD} = 3.3 V C _{EXT} = 22 pF C = C _{INT} + C _{EXT} + C _S	90 MHz	10.47	
			2 MHz	0.25	
			8 MHz	1.00	
			25 MHz	3.45	
		V _{DD} = 3.3 V C _{EXT} = 33 pF C = C _{INT} + C _{EXT} + C _S	50 MHz	7.15	
			60 MHz	11.55	
			2 MHz	0.32	
			8 MHz	1.27	
			25 MHz	3.88	
			50 MHz	12.34	

1. CS is the PCB board capacitance including the pad pin. CS = 7 pF (estimated value).



On-chip peripheral current consumption

The MCU is placed under the following conditions:

- At startup, all I/O pins are in analog input configuration.
- All peripherals are disabled unless otherwise mentioned.
- The ART accelerator is ON.
- Voltage Scale 2 mode selected, internal digital voltage V12 = 1.26 V.
- HCLK is the system clock at 100 MHz. $f_{PCLK1} = f_{HCLK}/2$, and $f_{PCLK2} = f_{HCLK}$.
The given value is calculated by measuring the difference of current consumption
 - with all peripherals clocked off
 - with only one peripheral clocked on
- Ambient operating temperature is 25 °C and $V_{DD}=3.3$ V.

Table 36. Peripheral current consumption

Peripheral		I _{DD} (Typ)			Unit
		Voltage scale1	Voltage scale2	Voltage scale3	
AHB1 (up to 100 MHz)	GPIOA	1.68	1.62	1.42	µA/MHz
	GPIOB	1.67	1.60	1.41	
	GPIOC	1.63	1.56	1.39	
	GPIOH	0.61	0.61	0.52	
	CRC	0.31	0.32	0.25	
	DMA1 ⁽¹⁾	1.67N + 3.12	1.60N + 2.96	1.43N + 2.64	
	DMA2 ⁽¹⁾	1.59N + 2.83	1.52N + 2.65	1.36N + 2.41	
	RNG	0.90	0.88	0.75	
APB1 (up to 50 MHz)	APB1 to AHB	0,78	0,74	0,63	µA/MHz
	TIM5	13,38	12,76	11,41	
	TIM6	2,14	1,98	1,75	
	LPTIM	8,22	7,88	7,06	
	WWDG	0,64	0,64	0,56	
	SPI2/I2S2	2,42	2,33	2,06	
	USART2	3,38	3,29	2,91	
	I2C1	3,46	3,33	2,97	
	I2C2	3,50	3,31	2,97	
	I2C4	4,82	4,64	4,09	
	PWR	0,66	0,64	0,62	
	DAC	0,84	0,81	0,78	

Table 36. Peripheral current consumption (continued)

Peripheral		I _{DD} (Typ)			Unit
		Voltage scale1	Voltage scale2	Voltage scale3	
APB2 (up to 100 MHz)	APB2 to AHB	0,22	0,19	0,17	μA/MHz
	TIM1	6,62	6,36	5,66	
	USART1	3,19	3,10	2,77	
	USART6	3,10	2,99	2,66	
	ADC1	3,35	3,25	2,88	
	SPI1/I2S1	1,82	1,77	1,58	
	SYSCFG	0,83	0,81	0,72	
	EXTI	0,92	0,88	0,80	
	TIM9	2,90	2,81	2,48	
	TIM11	2,13	2,06	1,81	
	SPI5/I2S5	1,88	1,83	1,59	
Bus matrix		1.91	1.82	1.64	

1. Valid if all the DMA streams are activated (please refer to the reference manual RM0401).

6.3.7 Wakeup time from low-power modes

The wakeup times given in [Table 37](#) are measured starting from the wakeup event trigger up to the first instruction executed by the CPU:

- For Stop or Sleep modes: the wakeup event is WFE.
- WKUP (PA0) pin is used to wakeup from Standby, Stop and Sleep modes.

Figure 18. Low-power mode wakeup

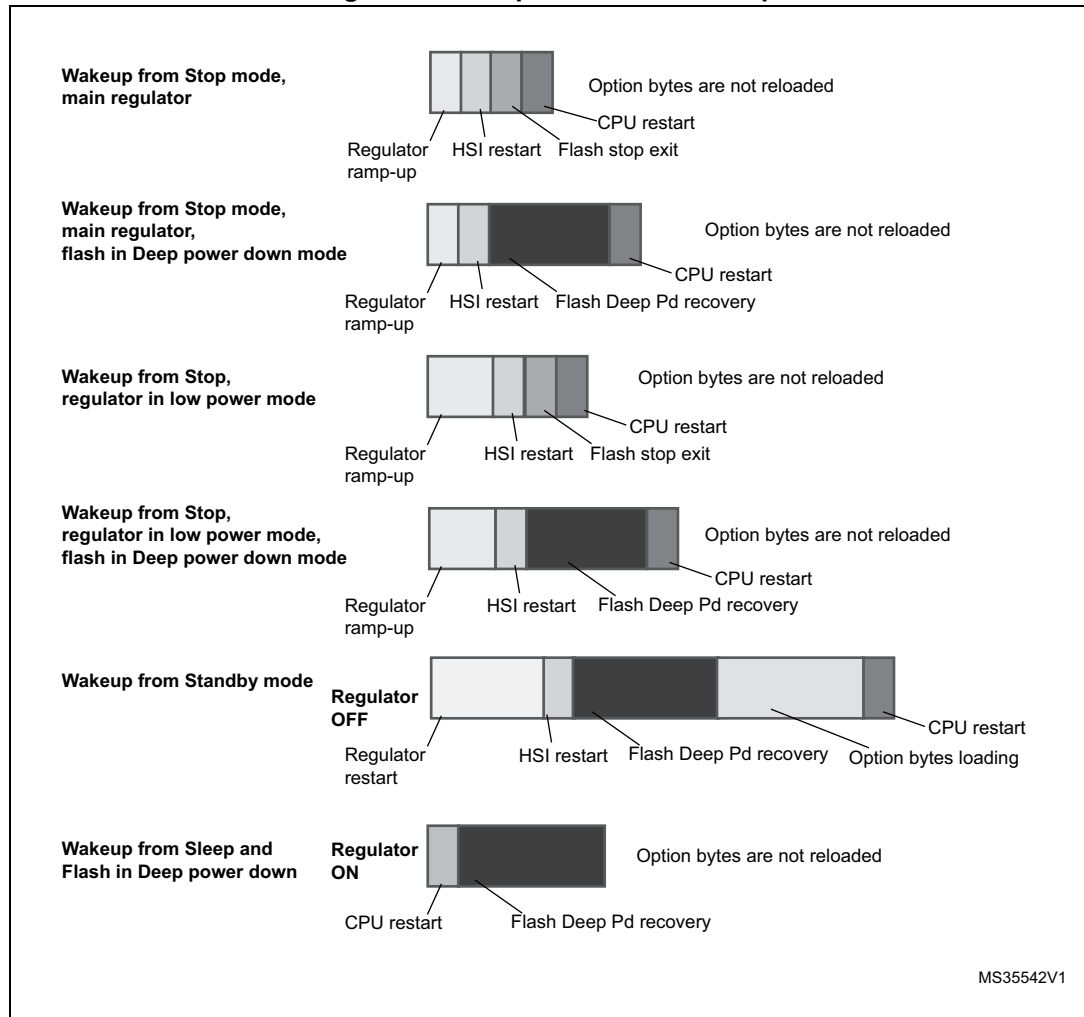

All timings are derived from tests performed under ambient temperature and $V_{DD}=3.3$ V.

Table 37. Low-power mode wakeup timings⁽¹⁾

Symbol	Parameter	Conditions	Min	Typ	Max	Unit
$t_{WUSLEEP}^{(2)}$	Wakeup from Sleep mode	-	-	4	6	CPU clock cycles
$t_{WUSLEEPFDSM}^{(2)}$		Flash memory in Deep power down mode	-	-	40,0	
$t_{WUSTOP}^{(2)}$	Wakeup from Stop mode, code execution from Flash memory	Main regulator	-	12.9	15.0	μs
		Main regulator, Flash memory in Deep power down mode	-	104.9	115.0	
		Regulator in low-power mode ⁽³⁾	-	20.8	25.0	
		Regulator in low-power mode, Flash memory in Deep power down mode	-	112.9	120.0	
	Wakeup from Stop mode, code execution from RAM	Main regulator, Flash memory in Stop or Deep power down mode	-	4.9	7.0	
		Regulator in low-power mode, Flash memory in Stop or Deep power down mode ⁽³⁾	-	12.8	20.0	
$t_{WUSTDBY}^{(2)(4)}$	Wakeup from Standby mode	-	-	316.8	350.0	
$t_{WUFLASH}$	Wakeup of Flash memory	From Flash_Stop mode	-	-	10.0	
	Wakeup of Flash memory	From Flash Deep power down mode	-	-	40.0	

1. Guaranteed by characterization.
2. The wakeup times are measured from the wakeup event to the point in which the application code reads the first instruction.
3. The specification is valid for wakeup from regulator in low power mode or in low power low voltage mode, since the timing difference is negligible.
4. $t_{WUSTDBY}$ maximum value is given at - 40 °C.

6.3.8 External clock source characteristics

High-speed external user clock generated from an external source

In bypass mode the HSE oscillator is switched off and the input pin is a standard I/O. The external clock signal has to respect the [Table 55](#). However, the recommended clock input waveform is shown in [Figure 19](#).

The characteristics given in [Table 38](#) result from tests performed using an high-speed external clock source, and under ambient temperature and supply voltage conditions summarized in [Table 15](#).

Table 38. High-speed external user clock characteristics

Symbol	Parameter	Conditions	Min	Typ	Max	Unit
f_{HSE_ext}	External user clock source frequency ⁽¹⁾		1	-	50	MHz
V_{HSEH}	OSC_IN input pin high level voltage	-	$0.7V_{DD}$	-	V_{DD}	V
V_{HSEL}	OSC_IN input pin low level voltage		V_{SS}	-	$0.3V_{DD}$	
$t_{w(HSE)}$ $t_{w(HSE)}$	OSC_IN high or low time ⁽¹⁾		5	-	-	ns
$t_{r(HSE)}$ $t_{f(HSE)}$	OSC_IN rise or fall time ⁽¹⁾		-	-	10	
$C_{in(HSE)}$	OSC_IN input capacitance ⁽¹⁾	-	-	5	-	pF
$DuCy_{(HSE)}$	Duty cycle	-	45	-	55	%
I_L	OSC_IN Input leakage current	$V_{SS} \leq V_{IN} \leq V_{DD}$	-	-	± 1	μA

1. Guaranteed by design.

Low-speed external user clock generated from an external source

In bypass mode the LSE oscillator is switched off and the input pin is a standard I/O. The external clock signal has to respect the [Table 55](#). However, the recommended clock input waveform is shown in [Figure 20](#).

The characteristics given in [Table 39](#) result from tests performed using an low-speed external clock source, and under ambient temperature and supply voltage conditions summarized in [Table 15](#).

Table 39. Low-speed external user clock characteristics

Symbol	Parameter	Conditions	Min	Typ	Max	Unit
f_{LSE_ext}	User External clock source frequency ⁽¹⁾		-	32.768	1000	kHz
V_{LSEH}	OSC32_IN input pin high level voltage	-	$0.7V_{DD}$	-	V_{DD}	V
V_{LSEL}	OSC32_IN input pin low level voltage		V_{SS}	-	$0.3V_{DD}$	
$t_{w(LSE)}$ $t_{f(LSE)}$	OSC32_IN high or low time ⁽¹⁾		450	-	-	ns
$t_{r(LSE)}$ $t_{f(LSE)}$	OSC32_IN rise or fall time ⁽¹⁾		-	-	50	
$C_{in(LSE)}$	OSC32_IN input capacitance ⁽¹⁾	-	-	5	-	pF
$DuCy_{(LSE)}$	Duty cycle	-	30	-	70	%
I_L	OSC32_IN Input leakage current	$V_{SS} \leq V_{IN} \leq V_{DD}$	-	-	± 1	μA

1. Guaranteed by design.

Figure 19. High-speed external clock source AC timing diagram

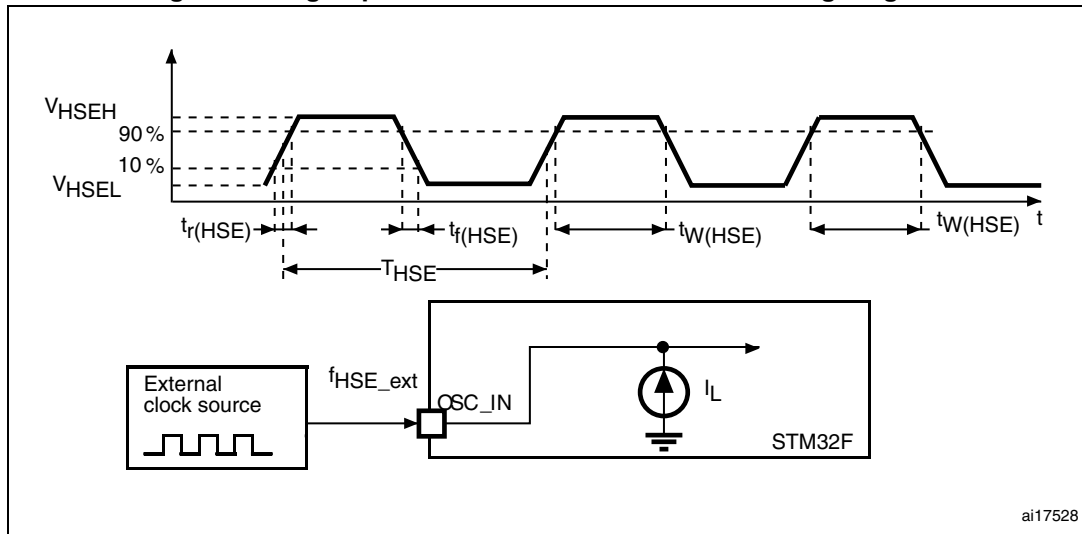
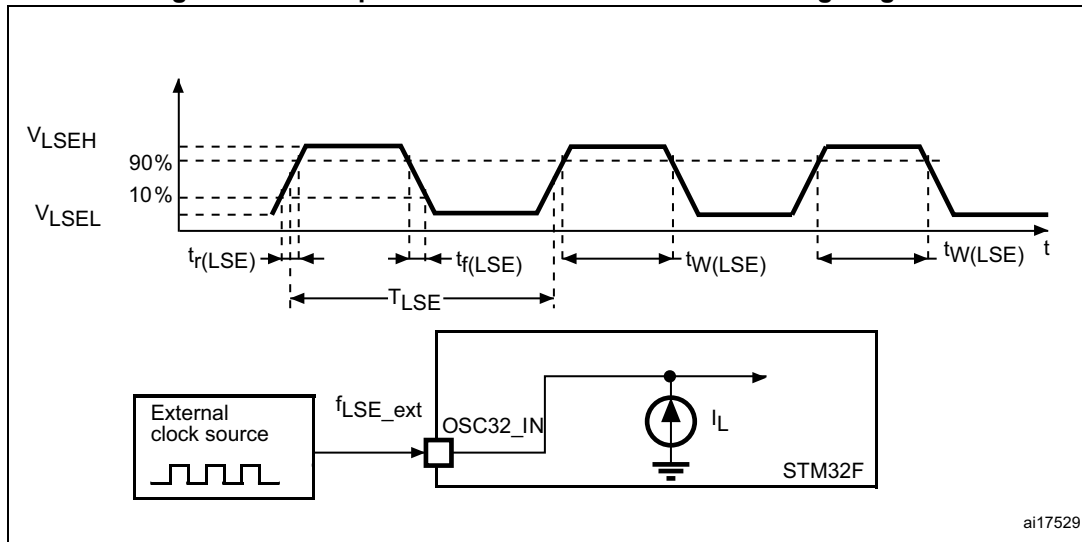

Figure 20. Low-speed external clock source AC timing diagram



High-speed external clock generated from a crystal/ceramic resonator

The high-speed external (HSE) clock can be supplied with a 4 to 26 MHz crystal/ceramic resonator oscillator. All the information given in this paragraph are based on characterization results obtained with typical external components specified in [Table 40](#). In the application, the resonator and the load capacitors have to be placed as close as possible to the oscillator pins in order to minimize output distortion and startup stabilization time. Refer to the crystal resonator manufacturer for more details on the resonator characteristics (frequency, package, accuracy).

Table 40. HSE 4-26 MHz oscillator characteristics⁽¹⁾

Symbol	Parameter	Conditions	Min	Typ	Max	Unit
f_{OSC_IN}	Oscillator frequency	-	4	-	26	MHz
R_F	Feedback resistor	-	-	200	-	k Ω
I_{DD}	HSE current consumption	$V_{DD}=3.3\text{ V}$, ESR= 30 Ω $C_L=5\text{ pF @}25\text{ MHz}$	-	450	-	μA
		$V_{DD}=3.3\text{ V}$, ESR= 30 Ω $C_L=10\text{ pF @}25\text{ MHz}$	-	530	-	
$G_{m_crit_max}$	Maximum critical crystal g_m	Startup	-	-	1	mA/V
$t_{SU(HSE)}^{(2)}$	Startup time	V_{DD} is stabilized	-	2	-	ms

1. Guaranteed by design.
2. $t_{SU(HSE)}$ is the startup time measured from the moment it is enabled (by software) to a stabilized 8 MHz oscillation is reached. This value is measured for a standard crystal resonator and it can vary significantly with the crystal manufacturer

For C_{L1} and C_{L2} , it is recommended to use high-quality external ceramic capacitors in the 5 pF to 25 pF range (Typ.), designed for high-frequency applications, and selected to match the requirements of the crystal or resonator (see [Figure 21](#)). C_{L1} and C_{L2} are usually the same size. The crystal manufacturer typically specifies a load capacitance which is the series combination of C_{L1} and C_{L2} . PCB and MCU pin capacitance must be included (10 pF can be used as a rough estimate of the combined pin and board capacitance) when sizing C_{L1} and C_{L2} .

Note: For information on selecting the crystal, refer to the application note AN2867 “Oscillator design guide for ST microcontrollers” available from the ST website www.st.com.

Figure 21. Typical application with an 8 MHz crystal

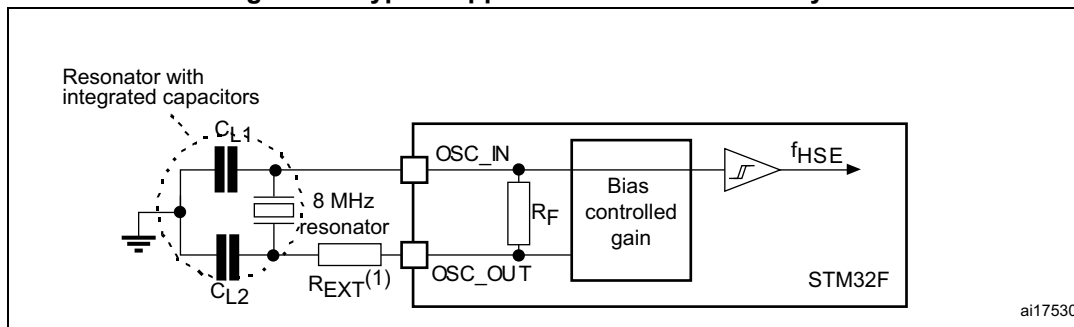

1. R_{EXT} value depends on the crystal characteristics.

Low-speed external clock generated from a crystal/ceramic resonator

The low-speed external (LSE) clock can be supplied with a 32.768 kHz crystal/ceramic resonator oscillator. All the information given in this paragraph are based on characterization results obtained with typical external components specified in [Table 41](#). In the application, the resonator and the load capacitors have to be placed as close as possible to the oscillator pins in order to minimize output distortion and startup stabilization time. Refer to the crystal resonator manufacturer for more details on the resonator characteristics (frequency, package, accuracy).

The LSE high-power mode allows to cover a wider range of possible crystals but with a cost of higher power consumption.

Table 41. LSE oscillator characteristics ($f_{LSE} = 32.768 \text{ kHz}$) ⁽¹⁾

Symbol	Parameter	Conditions	Min	Typ	Max	Unit
R_F	Feedback resistor	-	-	18.4	-	$M\Omega$
I_{DD}	LSE current consumption	Low-power mode (default)	-	-	1	μA
		High-drive mode	-	-	3	
$G_{m_crit_max}$	Maximum critical crystal g_m	Startup, low-power mode	-	-	0.56	$\mu A/V$
		Startup, high-drive mode	-	-	1.50	
$t_{SU(LSE)}^{(2)}$	startup time	V_{DD} is stabilized	-	2	-	s

1. Guaranteed by design.
2. $t_{SU(LSE)}$ is the startup time measured from the moment it is enabled (by software) to a stabilized 32.768 kHz oscillation is reached. This value is guaranteed by characterization. It is measured for a standard crystal resonator and it can vary significantly with the crystal manufacturer.

Note: For information on selecting the crystal, refer to the application note AN2867 “Oscillator design guide for ST microcontrollers” available from the ST website www.st.com.
 For information about the LSE high-power mode, refer to the reference manual RM0401.

Figure 22. Typical application with a 32.768 kHz crystal

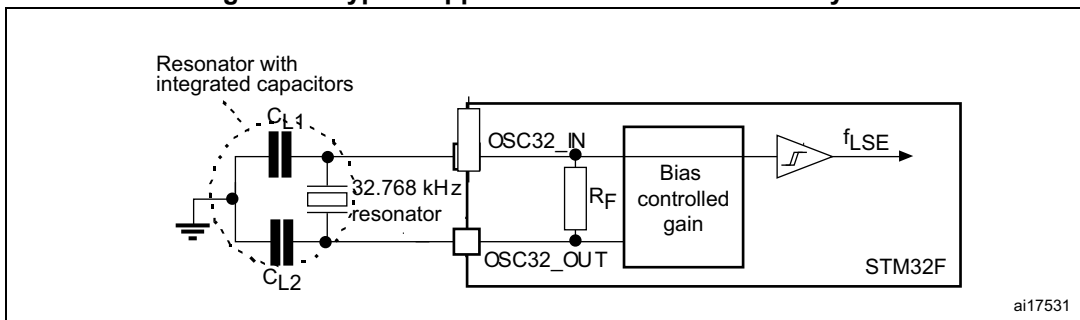

6.3.9 Internal clock source characteristics

The parameters given in [Table 42](#) and [Table 43](#) are derived from tests performed under ambient temperature and V_{DD} supply voltage conditions summarized in [Table 15](#).

High-speed internal (HSI) RC oscillator

Table 42. HSI oscillator characteristics (1)

Symbol	Parameter	Conditions	Min	Typ	Max	Unit	
f_{HSI}	Frequency	-	-	16	-	MHz	
ACC_{HSI}	Accuracy of the HSI oscillator	User-trimmed with the RCC_CR register ⁽²⁾	-	-	1	%	
		Factory-calibrated	$T_A = -40$ to 125 °C ⁽³⁾	-8	-	5.5	%
			$T_A = -10$ to 85 °C ⁽³⁾	-4	-	4	%
		$T_A = 25$ °C ⁽⁴⁾	-1	-	1	%	
$t_{su(HSI)}^{(2)}$	HSI oscillator startup time	-	-	2.2	4	µs	
$I_{DD(HSI)}^{(2)}$	HSI oscillator power consumption	-	-	60	80	µA	

- $V_{DD} = 3.3$ V, $T_A = -40$ to 125 °C unless otherwise specified.
- Guaranteed by design.
- Guaranteed by characterization.
- Factory calibrated non-soldered parts.

Figure 23. ACC_{HSI} versus temperature



- Guaranteed by characterization.

Low-speed internal (LSI) RC oscillator

Table 43. LSI oscillator characteristics ⁽¹⁾

Symbol	Parameter	Min	Typ	Max	Unit
$f_{LSI}^{(2)}$	Frequency	17	32	47	kHz
$t_{su(LSI)}^{(3)}$	LSI oscillator startup time	-	15	40	μs
$I_{DD(LSI)}^{(3)}$	LSI oscillator power consumption	-	0.4	0.6	μA

- $V_{DD} = 3 V, T_A = -40$ to $125\text{ }^\circ C$ unless otherwise specified.
- Guaranteed by characterization.
- Guaranteed by design.

Figure 24. ACC_{LSI} versus temperature

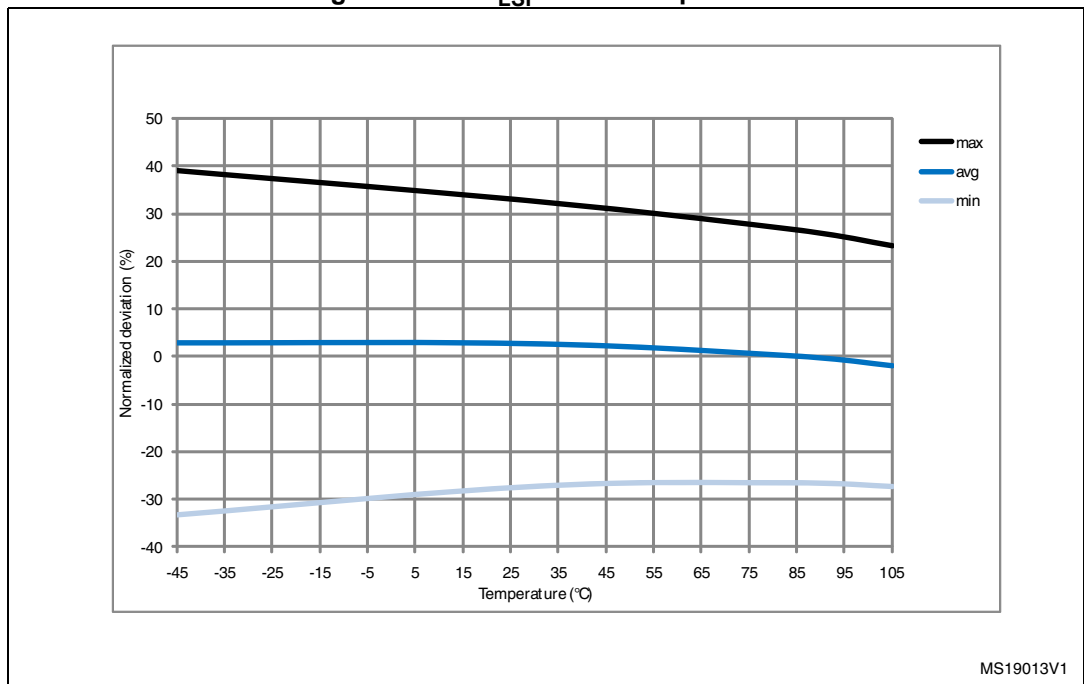

6.3.10 PLL characteristics

The parameters given in [Table 44](#) are derived from tests performed under temperature and V_{DD} supply voltage conditions summarized in [Table 15](#).

Table 44. Main PLL characteristics

Symbol	Parameter	Conditions	Min	Typ	Max	Unit
f_{PLL_IN}	PLL input clock ⁽¹⁾	-	0.95 ⁽²⁾	1	2.10	MHz
f_{PLL_OUT}	PLL multiplier output clock	-	24	-	100	MHz
f_{PLL48_OUT}	48 MHz PLL multiplier output clock	-	-	48	75	MHz
f_{VCO_OUT}	PLL VCO output	-	100	-	432	MHz

Table 44. Main PLL characteristics (continued)

Symbol	Parameter	Conditions	Min	Typ	Max	Unit	
t _{LOCK}	PLL lock time	VCO freq = 100 MHz	75	-	200	μs	
		VCO freq = 432 MHz	100	-	300		
Jitter ⁽³⁾	Cycle-to-cycle jitter	System clock 100 MHz	RMS	-	25	-	ps
			peak to peak	-	±150	-	
	Period Jitter		RMS	-	15	-	
			peak to peak	-	±200	-	
I _{DD(PLL)} ⁽⁴⁾	PLL power consumption on VDD	VCO freq = 100 MHz	0.15	-	0.40	mA	
		VCO freq = 432 MHz	0.45	-	0.75		
I _{DDA(PLL)} ⁽⁴⁾	PLL power consumption on VDDA	VCO freq = 100 MHz	0.30	-	0.40		
		VCO freq = 432 MHz	0.55	-	0.85		

1. Take care of using the appropriate division factor M to obtain the specified PLL input clock values. The M factor is shared between PLL and PLLI2S.
2. Guaranteed by design.
3. The use of two PLLs in parallel could degraded the Jitter up to +30%.
4. Guaranteed by characterization.

6.3.11 PLL spread spectrum clock generation (SSCG) characteristics

The spread spectrum clock generation (SSCG) feature allows to reduce electromagnetic interferences (see [Table 51: EMI characteristics for LQFP64](#)). It is available only on the main PLL.

Table 45. SSCG parameter constraints

Symbol	Parameter	Min	Typ	Max ⁽¹⁾	Unit
f_{Mod}	Modulation frequency	-	-	10	kHz
md	Peak modulation depth	0.25	-	2	%
MODEPER * INCSTEP	(Modulation period) * (Increment Step)	-	-	$2^{15}-1$	-

1. Guaranteed by design.

Equation 1

The frequency modulation period (MODEPER) is given by the equation below:

$$MODEPER = \text{round}[f_{PLL_IN} / (4 \times f_{Mod})]$$

f_{PLL_IN} and f_{Mod} must be expressed in Hz.

As an example:

If $f_{PLL_IN} = 1$ MHz, and $f_{MOD} = 1$ kHz, the modulation depth (MODEPER) is given by equation 1:

$$MODEPER = \text{round}[10^6 / (4 \times 10^3)] = 250$$

Equation 2

Equation 2 allows to calculate the increment step (INCSTEP):

$$INCSTEP = \text{round}[(2^{15} - 1) \times md \times PLLN] / (100 \times 5 \times MODEPER)$$

f_{VCO_OUT} must be expressed in MHz.

With a modulation depth (md) = ± 2 % (4 % peak to peak), and PLLN = 240 (in MHz):

$$INCSTEP = \text{round}[(2^{15} - 1) \times 2 \times 240] / (100 \times 5 \times 250) = 126md(\text{quantitized})\%$$

An amplitude quantization error may be generated because the linear modulation profile is obtained by taking the quantized values (rounded to the nearest integer) of MODPER and INCSTEP. As a result, the achieved modulation depth is quantized. The percentage quantized modulation depth is given by the following formula:

$$md_{\text{quantitized}}\% = (MODEPER \times INCSTEP \times 100 \times 5) / ((2^{15} - 1) \times PLLN)$$

As a result:

$$md_{\text{quantitized}}\% = (250 \times 126 \times 100 \times 5) / ((2^{15} - 1) \times 240) = 2.002\%(\text{peak})$$

Figure 25 and Figure 26 show the main PLL output clock waveforms in center spread and down spread modes, where:

- F0 is f_{PLL_OUT} nominal.
- T_{mode} is the modulation period.
- md is the modulation depth.

Figure 25. PLL output clock waveforms in center spread mode

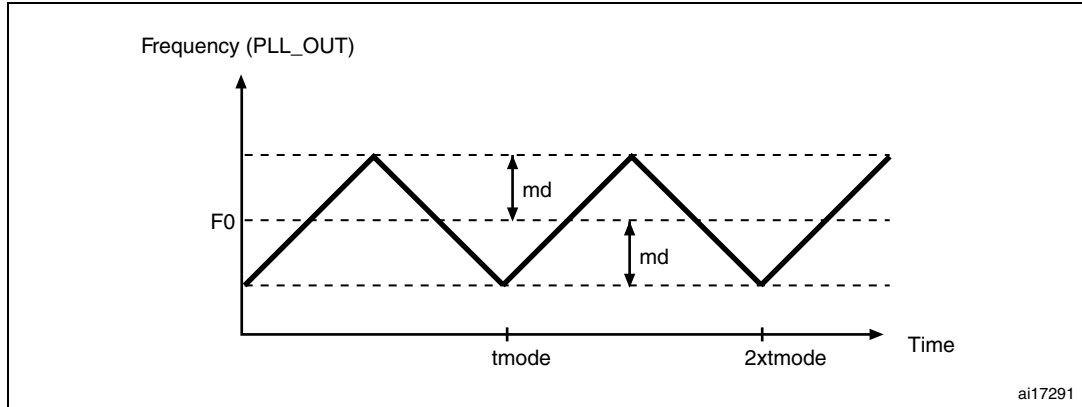
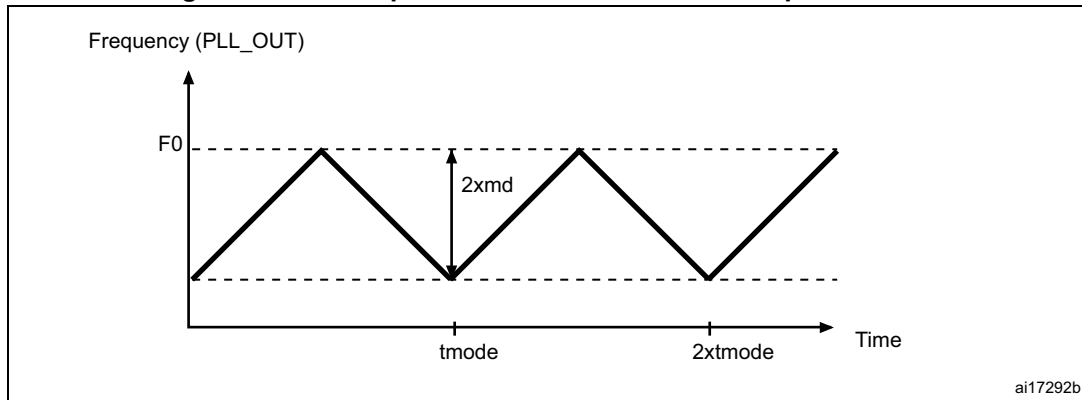

Figure 26. PLL output clock waveforms in down spread mode



6.3.12 Memory characteristics

Flash memory

The characteristics are given at $T_A = -40$ to 125 °C unless otherwise specified.

The devices are shipped to customers with the Flash memory erased.

Table 46. Flash memory characteristics

Symbol	Parameter	Conditions	Min	Typ	Max	Unit
I_{DD}	Supply current	Write / Erase 8-bit mode, $V_{DD} = 1.7$ V	-	5	-	mA
		Write / Erase 16-bit mode, $V_{DD} = 2.1$ V	-	8	-	
		Write / Erase 32-bit mode, $V_{DD} = 3.3$ V	-	12	-	

Table 47. Flash memory programming

Symbol	Parameter	Conditions	Min ⁽¹⁾	Typ	Max ⁽¹⁾	Unit
t _{prog}	Word programming time	Program/erase parallelism (PSIZE) = x 8/16/32	-	16	100 ⁽²⁾	µs
t _{ERASE16KB}	Sector (16 KB) erase time	Program/erase parallelism (PSIZE) = x 8	-	400	800	ms
		Program/erase parallelism (PSIZE) = x 16	-	300	600	
		Program/erase parallelism (PSIZE) = x 32	-	250	500	
t _{ERASE64KB}	Sector (64 KB) erase time	Program/erase parallelism (PSIZE) = x 8	-	1200	2400	ms
		Program/erase parallelism (PSIZE) = x 16	-	700	1400	
		Program/erase parallelism (PSIZE) = x 32	-	550	1100	
t _{ME}	Mass erase time	Program/erase parallelism (PSIZE) = x 8	-	2	4	s
		Program/erase parallelism (PSIZE) = x 16	-	1.4	2.8	
		Program/erase parallelism (PSIZE) = x 32	-	1	2	
V _{prog}	Programming voltage	32-bit program operation	2.7	-	3.6	V
		16-bit program operation	2.1	-	3.6	V
		8-bit program operation	1.7	-	3.6	V

1. Guaranteed by characterization.
2. The maximum programming time is measured after 100K erase operations.

Table 48. Flash memory programming with V_{PP} voltage

Symbol	Parameter	Conditions	Min ⁽¹⁾	Typ	Max ⁽¹⁾	Unit
t _{prog}	Double word programming	T _A = 0 to +40 °C V _{DD} = 3.3 V V _{PP} = 8.5 V	-	16	100 ⁽²⁾	µs
t _{ERASE16KB}	Sector (16 KB) erase time		-	230	-	ms
t _{ERASE64KB}	Sector (64 KB) erase time		-	490	-	
t _{ERASE128KB}	Sector (128 KB) erase time		-	875	-	
t _{ME}	Mass erase time		-	3.50	-	s
V _{prog}	Programming voltage	-	2.7	-	3.6	V
V _{PP}	V _{PP} voltage range	-	7	-	9	V
I _{PP}	Minimum current sunk on the V _{PP} pin	-	10	-	-	mA
t _{VPP} ⁽³⁾	Cumulative time during which V _{PP} is applied	-	-	-	1	hour

1. Guaranteed by design.
2. The maximum programming time is measured after 100K erase operations.
3. V_{PP} should only be connected during programming/erasing.

Table 49. Flash memory endurance and data retention

Symbol	Parameter	Conditions	Value	Unit
			Min ⁽¹⁾	
N_{END}	Endurance	$T_A = -40$ to $+85$ °C (6 suffix versions) $T_A = -40$ to $+105$ °C (7 suffix versions) $T_A = -40$ to $+125$ °C (3 suffix versions)	10	Kcycle
tRET	Data retention	1 kcycle ⁽²⁾ at $T_A = 85$ °C	30	Years
		1 kcycle ⁽²⁾ at $T_A = 105$ °C	10	
		1 kcycle ⁽²⁾ at $T_A = 125$ °C	3	
		10 kcycle ⁽²⁾ at $T_A = 55$ °C	20	

1. Guaranteed by characterization.
2. Cycling performed over the whole temperature range.

6.3.13 EMC characteristics

Susceptibility tests are performed on a sample basis during device characterization.

Functional EMS (electromagnetic susceptibility)

While a simple application is executed on the device (toggling 2 LEDs through I/O ports), the device is stressed by two electromagnetic events until a failure occurs. The failure is indicated by the LEDs:

- **Electrostatic discharge (ESD)** (positive and negative) is applied to all device pins until a functional disturbance occurs. This test is compliant with the IEC 61000-4-2 standard.
- **FTB:** A burst of fast transient voltage (positive and negative) is applied to V_{DD} and V_{SS} through a 100 pF capacitor, until a functional disturbance occurs. This test is compliant with the IEC 61000-4-4 standard.

A device reset allows normal operations to be resumed.

The test results are given in [Table 51](#). They are based on the EMS levels and classes defined in application note AN1709.

Table 50. EMS characteristics

Symbol	Parameter	Conditions	Level/Class
V_{FESD}	Voltage limits to be applied on any I/O pin to induce a functional disturbance	$V_{DD} = 3.3$ V, LQFP64, $T_A = +25$ °C, $f_{HCLK} = 100$ MHz, conforms to IEC 61000-4-2	2B
V_{EFTB}	Fast transient voltage burst limits to be applied through 100 pF on V_{DD} and V_{SS} pins to induce a functional disturbance	$V_{DD} = 3.3$ V, LQFP64, $T_A = +25$ °C, $f_{HCLK} = 100$ MHz, conforms to IEC 61000-4-4	4A

In noisy environments, it is recommended to avoid pin exposition to disturbances. The pins showing a middle range robustness are PA14 and PA15.

As a consequence, it is recommended to add a serial resistor (1 kΩ maximum) located as close as possible to the MCU pins exposed to noise (connected to tracks longer than 50 mm on PCB).

Designing hardened software to avoid noise problems

EMC characterization and optimization are performed at component level with a typical application environment and simplified MCU software. It should be noted that good EMC performance is highly dependent on the user application and the software in particular.

Therefore it is recommended that the user applies EMC software optimization and prequalification tests in relation with the EMC level requested for his application.

Software recommendations

The software flowchart must include the management of runaway conditions such as:

- Corrupted program counter
- Unexpected reset
- Critical Data corruption (control registers...)

Prequalification trials

Most of the common failures (unexpected reset and program counter corruption) can be reproduced by manually forcing a low state on the NRST pin or the Oscillator pins for 1 second.

To complete these trials, ESD stress can be applied directly on the device, over the range of specification values. When unexpected behavior is detected, the software can be hardened to prevent unrecoverable errors occurring (see application note AN1015).

Electromagnetic Interference (EMI)

The electromagnetic field emitted by the device are monitored while a simple application, executing EEMBC code, is running. This emission test is compliant with SAE IEC61967-2 standard which specifies the test board and the pin loading.

Table 51. EMI characteristics for LQFP64

Symbol	Parameter	Conditions	Monitored frequency band	Max vs. [f _{HSE} /f _{CPU}]	Unit
				8/100 MHz	
S _{EMI}	Peak level	V _{DD} = 3.6 V, T _A = 25 °C, conforming to IEC61967-2	0.1 to 30 MHz	10	dBμV
			30 to 130 MHz	11	
			130 MHz to 1 GHz	5	
			SAE EMI Level	2.5	-



6.3.14 Absolute maximum ratings (electrical sensitivity)

Based on three different tests (ESD, LU) using specific measurement methods, the device is stressed in order to determine its performance in terms of electrical sensitivity.

Electrostatic discharge (ESD)

Electrostatic discharges (a positive then a negative pulse separated by 1 second) are applied to the pins of each sample according to each pin combination. The sample size depends on the number of supply pins in the device (3 parts × (n+1) supply pins). This test conforms to the JESD22-A114/C101 standard.

Table 52. ESD absolute maximum ratings⁽¹⁾

Symbol	Ratings	Conditions	Class	Maximum value ⁽²⁾	Unit	
$V_{ESD(HBM)}$	Electrostatic discharge voltage (human body model)	$T_A = +25\text{ °C}$ conforming to ANSI/JEDEC JS-001	2	2000	V	
$V_{ESD(CDM)}$	Electrostatic discharge voltage (charge device model)	$T_A = +25\text{ °C}$ conforming to ANSI/ESD STM5.3.1	UFQFPN48	4		500
			WLCSP36	3		250
			LQFP48	4		500
			LQPF64	4		500
			UFBGA64	TBD		TBD

1. TBD stands for “to be defined”.
2. Guaranteed by characterization.

Static latchup

Two complementary static tests are required on six parts to assess the latchup performance:

- A supply overvoltage is applied to each power supply pin
- A current injection is applied to each input, output and configurable I/O pin

These tests are compliant with EIA/JESD 78A IC latchup standard.

Table 53. Electrical sensitivities

Symbol	Parameter	Conditions	Class
LU	Static latch-up class	$T_A = +125\text{ °C}$ conforming to JESD78A	II level A

6.3.15 I/O current injection characteristics

As a general rule, current injection to the I/O pins, due to external voltage below V_{SS} or above V_{DD} (for standard, 3 V-capable I/O pins) should be avoided during normal product operation. However, in order to give an indication of the robustness of the microcontroller in cases when abnormal injection accidentally happens, susceptibility tests are performed on a sample basis during device characterization.

Functional susceptibility to I/O current injection

While a simple application is executed on the device, the device is stressed by injecting current into the I/O pins programmed in floating input mode. While current is injected into the I/O pin, one at a time, the device is checked for functional failures.

The failure is indicated by an out of range parameter: ADC error above a certain limit (>5 LSB TUE), out of conventional limits of induced leakage current on adjacent pins (out of $-5 \mu\text{A}/+0 \mu\text{A}$ range), or other functional failure (for example reset, oscillator frequency deviation).

Negative induced leakage current is caused by negative injection and positive induced leakage current by positive injection.

The test results are given in [Table 54](#).

Table 54. I/O current injection susceptibility⁽¹⁾

Symbol	Description	Functional susceptibility		Unit
		Negative injection	Positive injection	
I _{INJ}	Injected current on BOOT0 pin	- 0	NA	mA
	Injected current on NRST pin	- 0	NA	
	Injected current on PB3, PB4, PB5, PB6, PB7, PB8, PB9, PC13, PC14, PC15, PH1, PDR_ON, PC0, PC1, PC2, PC3	- 0	NA	
	Injected current on any other FT pin	- 5	NA	
	Injected current on any other pins	- 5	+ 5	

1. NA = not applicable.

Note: It is recommended to add a Schottky diode (pin to ground) to analog pins which may potentially inject negative currents.

6.3.16 I/O port characteristics

General input/output characteristics

Unless otherwise specified, the parameters given in [Table 55](#) are derived from tests performed under the conditions summarized in [Table 15](#). All I/Os are CMOS and TTL compliant.

Table 55. I/O static characteristics

Symbol	Parameter	Conditions	Min	Typ	Max	Unit
V _{IL}	FT, TC and NRST I/O input low level voltage	$1.7 \text{ V} \leq V_{\text{DD}} \leq 3.6 \text{ V}$	-	-	$0.3V_{\text{DD}}^{(1)}$	V
	BOOT0 I/O input low level voltage	$1.75 \text{ V} \leq V_{\text{DD}} \leq 3.6 \text{ V}$, $-40 \text{ }^\circ\text{C} \leq T_{\text{A}} \leq 125 \text{ }^\circ\text{C}$	-	-	$0.1V_{\text{DD}} + 0.1^{(2)}$	
		$1.7 \text{ V} \leq V_{\text{DD}} \leq 3.6 \text{ V}$, $0 \text{ }^\circ\text{C} \leq T_{\text{A}} \leq 125 \text{ }^\circ\text{C}$	-	-		

Table 55. I/O static characteristics (continued)

Symbol	Parameter		Conditions	Min	Typ	Max	Unit
V_{IH}	FT, TC and NRST I/O input high level voltage ⁽⁵⁾		$1.7 V \leq V_{DD} \leq 3.6 V$	$0.7V_{DD}^{(1)}$	-	-	V
	BOOT0 I/O input high level voltage		$1.75 V \leq V_{DD} \leq 3.6 V$, $-40\text{ }^{\circ}\text{C} \leq T_A \leq 125\text{ }^{\circ}\text{C}$	$0.17V_{DD} + 0.7^{(2)}$	-	-	
			$1.7 V \leq V_{DD} \leq 3.6 V$, $0\text{ }^{\circ}\text{C} \leq T_A \leq 125\text{ }^{\circ}\text{C}$				
V_{HYS}	FT, TC and NRST I/O input hysteresis		$1.7 V \leq V_{DD} \leq 3.6 V$	-	$10\% V_{DD}^{(3)}$	-	V
	BOOT0 I/O input hysteresis		$1.75 V \leq V_{DD} \leq 3.6 V$, $-40\text{ }^{\circ}\text{C} \leq T_A \leq 125\text{ }^{\circ}\text{C}$	-	100	-	mV
			$1.7 V \leq V_{DD} \leq 3.6 V$, $0\text{ }^{\circ}\text{C} \leq T_A \leq 125\text{ }^{\circ}\text{C}$				
I_{lkg}	I/O input leakage current ⁽⁴⁾		$V_{SS} \leq V_{IN} \leq V_{DD}$	-	-	± 1	μA
	I/O FT/TC input leakage current ⁽⁵⁾		$V_{IN} = 5 V$	-	-	3	
R_{PU}	Weak pull-up equivalent resistor ⁽⁶⁾	All pins except for PA10 (OTG_FS_ID)	$V_{IN} = V_{SS}$	30	40	50	k Ω
		PA10 (OTG_FS_ID)	-	7	10	14	
R_{PD}	Weak pull-down equivalent resistor ⁽⁷⁾	All pins except for PA10 (OTG_FS_ID)	$V_{IN} = V_{DD}$	30	40	50	k Ω
		PA10 (OTG_FS_ID)	-	7	10	14	
$C_{IO}^{(8)}$	I/O pin capacitance		-	-	5	-	pF

1. Guaranteed by tests in production.
2. Guaranteed by design.
3. With a minimum of 200 mV.
4. Leakage could be higher than the maximum value, if negative current is injected on adjacent pins, Refer to [Table 54: I/O current injection susceptibility](#)
5. To sustain a voltage higher than $V_{DD} + 0.3 V$, the internal pull-up/pull-down resistors must be disabled. Leakage could be higher than the maximum value, if negative current is injected on adjacent pins. Refer to [Table 54: I/O current injection susceptibility](#)
6. Pull-up resistors are designed with a true resistance in series with a switchable PMOS. This PMOS contribution to the series resistance is minimum (~10% order).
7. Pull-down resistors are designed with a true resistance in series with a switchable NMOS. This NMOS contribution to the series resistance is minimum (~10% order).
8. Hysteresis voltage between Schmitt trigger switching levels. Guaranteed by characterization.

All I/Os are CMOS and TTL compliant (no software configuration required). Their characteristics cover more than the strict CMOS-technology or TTL parameters. The coverage of these requirements for FT and TC I/Os is shown in [Figure 27](#).

Figure 27. FT/TC I/O input characteristics

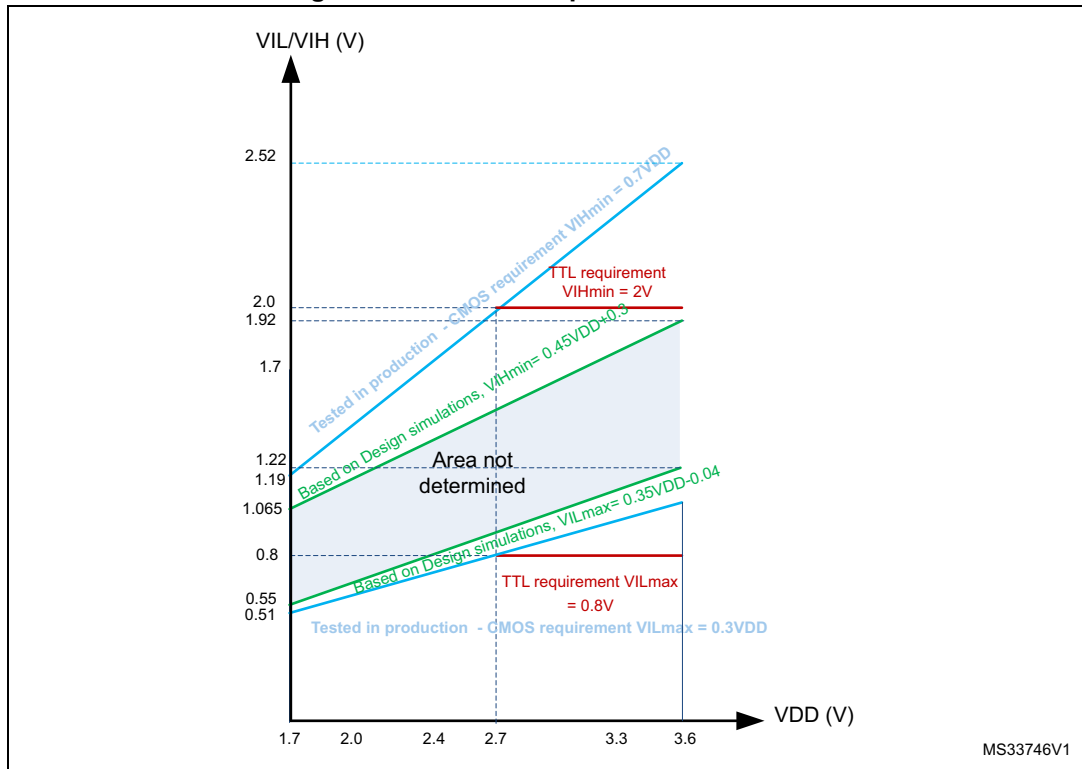

Output driving current

The GPIOs (general purpose input/outputs) can sink or source up to ± 8 mA, and sink or source up to ± 20 mA (with a relaxed V_{OL}/V_{OH}) except PC13, PC14 and PC15 which can sink or source up to ± 3 mA. When using the PC13 to PC15 GPIOs in output mode, the speed should not exceed 2 MHz with a maximum load of 30 pF.

In the user application, the number of I/O pins which can drive current must be limited to respect the absolute maximum rating specified in [Section 6.2](#). In particular:

- The sum of the currents sourced by all the I/Os on V_{DD} , plus the maximum Run consumption of the MCU sourced on V_{DD} , cannot exceed the absolute maximum rating ΣI_{VDD} (see [Table 13](#)).
- The sum of the currents sunk by all the I/Os on V_{SS} plus the maximum Run consumption of the MCU sunk on V_{SS} cannot exceed the absolute maximum rating ΣI_{VSS} (see [Table 13](#)).

Output voltage levels

Unless otherwise specified, the parameters given in [Table 56](#) are derived from tests performed under ambient temperature and V_{DD} supply voltage conditions summarized in [Table 15](#). All I/Os are CMOS and TTL compliant.

Table 56. Output voltage characteristics

Symbol	Parameter	Conditions	Min	Max	Unit
$V_{OL}^{(1)}$	Output low level voltage for an I/O pin	CMOS port ⁽²⁾ $I_{IO} = +8 \text{ mA}$ $2.7 \text{ V} \leq V_{DD} \leq 3.6 \text{ V}$	-	0.4	V
$V_{OH}^{(3)}$	Output high level voltage for an I/O pin		$V_{DD}-0.4$	-	
$V_{OL}^{(1)}$	Output low level voltage for an I/O pin	TTL port ⁽²⁾ $I_{IO} = +8 \text{ mA}$ $2.7 \text{ V} \leq V_{DD} \leq 3.6 \text{ V}$	-	0.4	V
$V_{OH}^{(3)}$	Output high level voltage for an I/O pin		2.4	-	
$V_{OL}^{(1)}$	Output low level voltage for an I/O pin	$I_{IO} = +20 \text{ mA}$ $2.7 \text{ V} \leq V_{DD} \leq 3.6 \text{ V}$	-	1.3 ⁽⁴⁾	V
$V_{OH}^{(3)}$	Output high level voltage for an I/O pin		$V_{DD}-1.3^{(4)}$	-	
$V_{OL}^{(1)}$	Output low level voltage for an I/O pin	$I_{IO} = +6 \text{ mA}$ $1.8 \text{ V} \leq V_{DD} \leq 3.6 \text{ V}$	-	0.4 ⁽⁴⁾	V
$V_{OH}^{(3)}$	Output high level voltage for an I/O pin		$V_{DD}-0.4^{(4)}$	-	
$V_{OL}^{(1)}$	Output low level voltage for an I/O pin	$I_{IO} = +4 \text{ mA}$ $1.7 \text{ V} \leq V_{DD} \leq 3.6 \text{ V}$	-	0.4 ⁽⁵⁾	V
$V_{OH}^{(3)}$	Output high level voltage for an I/O pin		$V_{DD}-0.4^{(5)}$	-	

1. The I_{IO} current sunk by the device must always respect the absolute maximum rating specified in [Table 13](#) and the sum of I_{IO} (I/O ports and control pins) must not exceed I_{VSS} .
2. TTL and CMOS outputs are compatible with JEDEC standards JESD36 and JESD52.
3. The I_{IO} current sourced by the device must always respect the absolute maximum rating specified in [Table 13](#) and the sum of I_{IO} (I/O ports and control pins) must not exceed I_{VDD} .
4. Guaranteed by characterization results.
5. Guaranteed by design.

Input/output AC characteristics

The definition and values of input/output AC characteristics are given in [Figure 28](#) and [Table 57](#), respectively.

Unless otherwise specified, the parameters given in [Table 57](#) are derived from tests performed under the ambient temperature and V_{DD} supply voltage conditions summarized in [Table 15](#).

Table 57. I/O AC characteristics⁽¹⁾⁽²⁾

OSPEEDRy [1:0] bit value ⁽¹⁾	Symbol	Parameter	Conditions	Min	Typ	Max	Unit
00	$f_{\text{max}(IO)\text{out}}$	Maximum frequency ⁽³⁾	$C_L = 50 \text{ pF}, V_{DD} \geq 2.70 \text{ V}$	-	-	4	MHz
			$C_L = 50 \text{ pF}, V_{DD} \geq 1.7 \text{ V}$	-	-	2	
			$C_L = 10 \text{ pF}, V_{DD} \geq 2.70 \text{ V}$	-	-	8	
			$C_L = 10 \text{ pF}, V_{DD} \geq 1.7 \text{ V}$	-	-	4	
	$t_{f(I O)\text{out}} / t_{r(I O)\text{out}}$	Output high to low level fall time and output low to high level rise time	$C_L = 50 \text{ pF}, V_{DD} = 1.7 \text{ V to } 3.6 \text{ V}$	-	-	100	ns

Table 57. I/O AC characteristics⁽¹⁾⁽²⁾ (continued)

OSPEEDRy [1:0] bit value ⁽¹⁾	Symbol	Parameter	Conditions	Min	Typ	Max	Unit	
01	f _{max(IO)out}	Maximum frequency ⁽³⁾	C _L = 50 pF, V _{DD} ≥ 2.70 V	-	-	25	MHz	
			C _L = 50 pF, V _{DD} ≥ 1.7 V	-	-	12.5		
			C _L = 10 pF, V _{DD} ≥ 2.70 V	-	-	50		
			C _L = 10 pF, V _{DD} ≥ 1.7 V	-	-	20		
	t _{f(IO)out} / t _{r(IO)out}	Output high to low level fall time and output low to high level rise time	C _L = 50 pF, V _{DD} ≥ 2.7 V	-	-	10	ns	
			C _L = 50 pF, V _{DD} ≥ 1.7 V	-	-	20		
			C _L = 10 pF, V _{DD} ≥ 2.70 V	-	-	6		
			C _L = 10 pF, V _{DD} ≥ 1.7 V	-	-	10		
10	f _{max(IO)out}	Maximum frequency ⁽³⁾	C _L = 40 pF, V _{DD} ≥ 2.70 V	-	-	50 ⁽⁴⁾	MHz	
			C _L = 40 pF, V _{DD} ≥ 1.7 V	-	-	25		
			C _L = 10 pF, V _{DD} ≥ 2.70 V	-	-	100 ⁽⁴⁾		
			C _L = 10 pF, V _{DD} ≥ 1.7 V	-	-	50 ⁽⁴⁾		
	t _{f(IO)out} / t _{r(IO)out}	Output high to low level fall time and output low to high level rise time	C _L = 40 pF, V _{DD} ≥ 2.70 V	-	-	6	ns	
			C _L = 40 pF, V _{DD} ≥ 1.7 V	-	-	10		
			C _L = 10 pF, V _{DD} ≥ 2.70 V	-	-	4		
			C _L = 10 pF, V _{DD} ≥ 1.7 V	-	-	6		
11	F _{max(IO)out}	Maximum frequency ⁽³⁾	C _L = 30 pF, V _{DD} ≥ 2.70 V	-	-	100 ⁽⁴⁾	MHz	
			C _L = 30 pF, V _{DD} ≥ 1.7 V	-	-	50 ⁽⁴⁾		
	t _{f(IO)out} / t _{r(IO)out}	Output high to low level fall time and output low to high level rise time	C _L = 30 pF, V _{DD} ≥ 2.70 V	-	-	4	ns	
			C _L = 30 pF, V _{DD} ≥ 1.7 V	-	-	6		
			C _L = 10 pF, V _{DD} ≥ 2.70 V	-	-	2.5		
			C _L = 10 pF, V _{DD} ≥ 1.7 V	-	-	4		
	-	t _{EXTIpw}	Pulse width of external signals detected by the EXTI controller	-	10	-	-	ns

1. Guaranteed by characterization.
2. The I/O speed is configured using the OSPEEDRy[1:0] bits. Refer to the STM32F4xx reference manual for a description of the GPIOx_SPEEDR GPIO port output speed register.
3. The maximum frequency is defined in [Figure 28](#).
4. For maximum frequencies above 50 MHz and V_{DD} > 2.4 V, the compensation cell should be used.

Figure 28. I/O AC characteristics definition

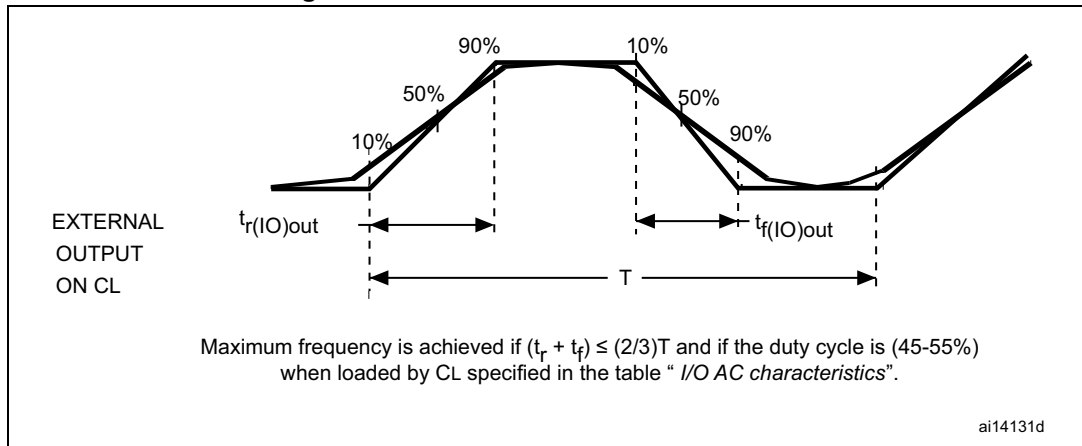

6.3.17 NRST pin characteristics

The NRST pin input driver uses CMOS technology. It is connected to a permanent pull-up resistor, R_{PU} (see [Table 55](#)).

Unless otherwise specified, the parameters given in [Table 58](#) are derived from tests performed under the ambient temperature and V_{DD} supply voltage conditions summarized in [Table 15](#). Refer to [Table 55: I/O static characteristics](#) for the values of V_{IH} and V_{IL} for NRST pin.

Table 58. NRST pin characteristics

Symbol	Parameter	Conditions	Min	Typ	Max	Unit
R_{PU}	Weak pull-up equivalent resistor ⁽¹⁾	$V_{IN} = V_{SS}$	30	40	50	k Ω
$V_{F(NRST)}^{(2)}$	NRST Input filtered pulse	-	-	-	100	ns
$V_{NF(NRST)}^{(2)}$	NRST Input not filtered pulse	$V_{DD} > 2.7 V$	300	-	-	ns
T_{NRST_OUT}	Generated reset pulse duration	Internal Reset source	20	-	-	μs

1. The pull-up is designed with a true resistance in series with a switchable PMOS. This PMOS contribution to the series resistance must be minimum (~10% order).
2. Guaranteed by design.

Figure 29. Recommended NRST pin protection

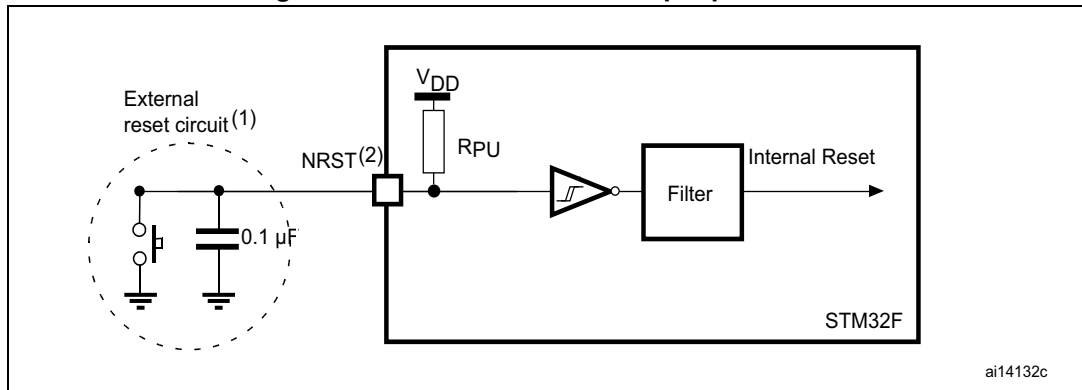

1. The reset network protects the device against parasitic resets.
2. The user must ensure that the level on the NRST pin can go below the $V_{IL(NRST)}$ max level specified in [Table 58](#). Otherwise the reset is not taken into account by the device.

6.3.18 TIM timer characteristics

The parameters given in [Table 59](#) are guaranteed by design.

Refer to [Section 6.3.16: I/O port characteristics](#) for details on the input/output alternate function characteristics (output compare, input capture, external clock, PWM output).

Table 59. TIMx characteristics⁽¹⁾⁽²⁾

Symbol	Parameter	Conditions ⁽³⁾	Min	Max	Unit
$t_{res(TIM)}$	Timer resolution time	AHB/APBx prescaler=1 or 2 or 4, $f_{TIMxCLK} = 100$ MHz	1	-	$t_{TIMxCLK}$
			11.9	-	ns
		AHB/APBx prescaler>4, $f_{TIMxCLK} = 100$ MHz	1	-	$t_{TIMxCLK}$
			11.9	-	ns
f_{EXT}	Timer external clock frequency on CH1 to CH4	$f_{TIMxCLK} = 100$ MHz	0	$f_{TIMxCLK}/2$	MHz
			0	50	MHz
			-	16/32	bit
Res_{TIM}	Timer resolution				
$t_{COUNTER}$	16-bit counter clock period when internal clock is selected	$f_{TIMxCLK} = 100$ MHz	0.0119	780	μs
t_{MAX_COUNT}	Maximum possible count with 32-bit counter	-	-	65536×65536	$t_{TIMxCLK}$
		$f_{TIMxCLK} = 100$ MHz	-	51.1	S

1. TIMx is used as a general term to refer to the TIM1 to TIM11 timers.
2. Guaranteed by design.
3. The maximum timer frequency on APB1 is 50 MHz and on APB2 is up to 100 MHz, by setting the TIMPRE bit in the RCC_DCKCFGR register, if APBx prescaler is 1 or 2 or 4, then $TIMxCLK = HCKL$, otherwise $TIMxCLK \geq 4 \times PCLKx$.

6.3.19 Communications interfaces

I²C interface characteristics

The I²C interface meets the requirements of the standard I²C communication protocol with the following restrictions: the I/O pins SDA and SCL are mapped to are not “true” open-drain. When configured as open-drain, the PMOS connected between the I/O pin and V_{DD} is disabled, but is still present.

The I²C characteristics are described in [Table 60](#). Refer also to [Section 6.3.16: I/O port characteristics](#) for more details on the input/output alternate function characteristics (SDA and SCL).

The I²C bus interface supports standard mode (up to 100 kHz) and fast mode (up to 400 kHz). The I²C bus frequency can be increased up to 1 MHz. For more details about the complete solution, please contact your local ST sales representative.

Table 60. I²C characteristics

Symbol	Parameter	Standard mode I ² C ⁽¹⁾⁽²⁾		Fast mode I ² C ⁽¹⁾⁽²⁾		Unit
		Min	Max	Min	Max	
t _w (SCLL)	SCL clock low time	4.7	-	1.3	-	μs
t _w (SCLH)	SCL clock high time	4.0	-	0.6	-	
t _{su} (SDA)	SDA setup time	250	-	100	-	ns
t _h (SDA)	SDA data hold time	0	3450 ⁽³⁾	0	900 ⁽⁴⁾	
t _r (SDA) t _r (SCL)	SDA and SCL rise time	-	1000	-	300	
t _f (SDA) t _f (SCL)	SDA and SCL fall time	-	300	-	300	
t _h (STA)	Start condition hold time	4.0	-	0.6	-	μs
t _{su} (STA)	Repeated Start condition setup time	4.7	-	0.6	-	
t _{su} (STO)	Stop condition setup time	4.0	-	0.6	-	μs
t _w (STO:STA)	Stop to Start condition time (bus free)	4.7	-	1.3	-	μs
t _{SP}	Pulse width of the spikes that are suppressed by the analog filter for standard fast mode	0	50 ⁽⁵⁾	0	50 ⁽⁵⁾	ns
C _b	Capacitive load for each bus line	-	400	-	400	pF

1. Guaranteed by design.
2. f_{PCLK1} must be at least 2 MHz to achieve standard mode I²C frequencies. It must be at least 4 MHz to achieve fast mode I²C frequencies, and a multiple of 10 MHz to reach the 400 kHz maximum I²C fast mode clock.
3. The device must internally provide a hold time of at least 300 ns for the SDA signal in order to bridge the undefined region of the falling edge of SCL.

4. The maximum data hold time has only to be met if the interface does not stretch the low period of SCL signal.
5. The minimum width of the spikes filtered by the analog filter is above t_{SP} (max)

Figure 30. I²C bus AC waveforms and measurement circuit

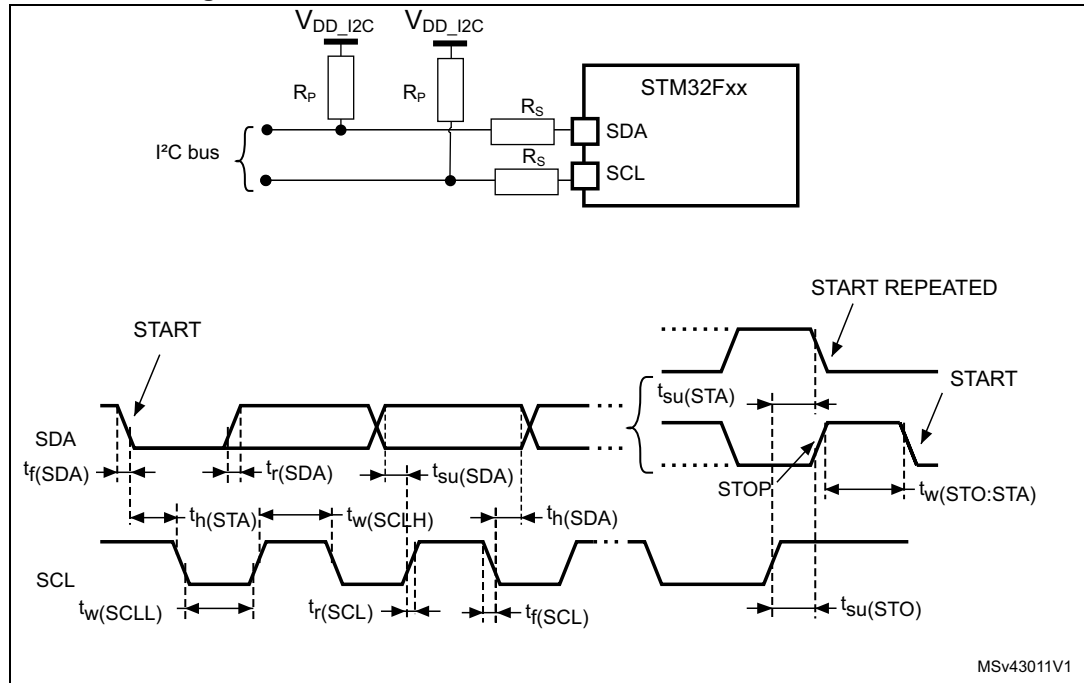

1. R_S = series protection resistor.
2. R_P = external pull-up resistor.
3. V_{DD_I2C} is the I2C bus power supply.

Table 61. SCL frequency ($f_{PCLK1} = 50$ MHz, $V_{DD} = V_{DD_I2C} = 3.3$ V)⁽¹⁾⁽²⁾

f_{SCL} (kHz)	I2C_CCR value
	$R_P = 4.7$ k Ω
400	0x8019
300	0x8021
200	0x8032
100	0x0096
50	0x012C
20	0x02EE

1. R_P = External pull-up resistance, $f_{SCL} = I^2C$ speed
2. For speeds around 200 kHz, the tolerance on the achieved speed is of $\pm 5\%$. For other speed ranges, the tolerance on the achieved speed is $\pm 2\%$. These variations depend on the accuracy of the external components used to design the application.

Table 62. SCL frequency ($f_{PCLK1} = 42 \text{ MHz}$, $V_{DD} = V_{DD_I2C} = 3.3 \text{ V}$)⁽¹⁾⁽²⁾

f_{SCL} (kHz)	I2C_CCR value
	$R_p = 4.7 \text{ k}\Omega$
400	0x8019
300	0x8021
200	0x8032
100	0x0096
50	0x012C
20	0x02EE

1. R_p = External pull-up resistance, f_{SCL} = I²C speed,
2. For speeds around 200 kHz, the tolerance on the achieved speed is of $\pm 5\%$. For other speed ranges, the tolerance on the achieved speed $\pm 2\%$. These variations depend on the accuracy of the external components used to design the application.

FMPI²C characteristics

The FMPI2C characteristics are described in [Table 63](#).

Refer also to [Section 6.3.16: I/O port characteristics](#) for more details on the input/output alternate function characteristics (SDA and SCL).

Table 63. FMPI²C characteristics⁽¹⁾

-	Parameter	Standard mode		Fast mode		Fast+ mode		Unit
		Min	Max	Min	Max	Min	Max	
f _{FMPI2CC}	FMPI2CCLK frequency	2	-	8	-	17 16 ⁽²⁾	-	us
t _{w(SCLL)}	SCL clock low time	4.7	-	1.3	-	0.5	-	
t _{w(SCLH)}	SCL clock high time	4.0	-	0.6	-	0.26	-	
t _{su(SDA)}	SDA setup time	0.25	-	0.10	-	0.05	-	
t _{H(SDA)}	SDA data hold time	0	-	0	-	0	-	
t _{v(SDA,ACK)}	Data, ACK valid time	-	3.45	-	0.9	-	0.45	
t _{r(SDA)} t _{r(SCL)}	SDA and SCL rise time	-	0.100	-	0.30	-	0.12	
t _{f(SDA)} t _{f(SCL)}	SDA and SCL fall time	-	0.30	-	0.30	-	0.12	
t _{h(STA)}	Start condition hold time	4	-	0.6	-	0.26	-	
t _{su(STA)}	Repeated Start condition setup time	4.7	-	0.6	-	0.26	-	
t _{su(STO)}	Stop condition setup time	4	-	0.6	-	0.26	-	
t _{w(STO:STA)}	Stop to Start condition time (bus free)	4.7	-	1.3	-	0.5	-	
t _{SP}	Pulse width of the spikes that are suppressed by the analog filter for standard and fast mode	-	-	0.05	0.09	0.05	0.09	
C _b	Capacitive load for each bus Line	-	400	-	400	-	550 ⁽³⁾	pF

1. Guaranteed based on test during characterization.
2. When tr(SDA,SCL)<=110 ns.
3. Can be limited. Maximum supported value can be retrieved by referring to the following formulas:

$$t_{r(SDA/SCL)} = 0.8473 \times R_p \times C_{load}$$

$$R_{p(min)} = (V_{DD} - V_{OL(max)}) / I_{OL(max)}$$

Figure 31. FMPI²C timing diagram and measurement circuit

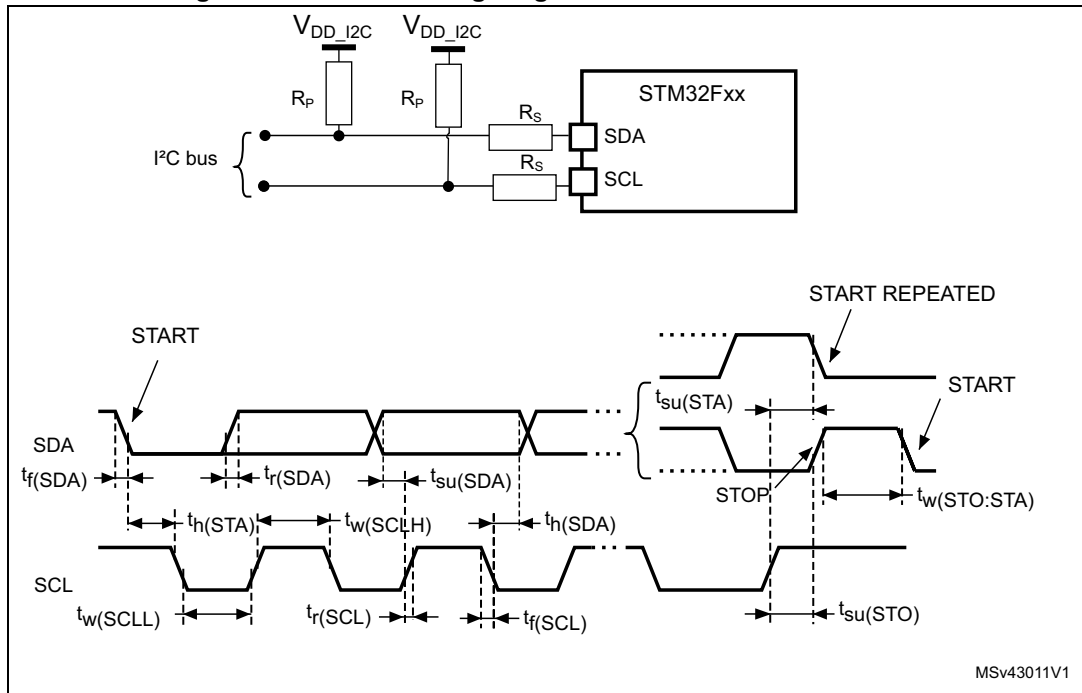

SPI interface characteristics

Unless otherwise specified, the parameters given in [Table 64](#) for the SPI interface are derived from tests performed under the ambient temperature, f_{PCLKX} frequency and V_{DD} supply voltage conditions summarized in [Table 15](#), with the following configuration:

- Output speed is set to OSPEEDRy[1:0] = 10
- Capacitive load C = 30 pF
- Measurement points are done at CMOS levels: $0.5V_{DD}$

Refer to [Section 6.3.16: I/O port characteristics](#) for more details on the input/output alternate function characteristics (NSS, SCK, MOSI, MISO for SPI).

Table 64. SPI dynamic characteristics⁽¹⁾

Symbol	Parameter	Conditions	Min	Typ	Max	Unit
f_{SCK} $1/t_{c(SCK)}$	SPI clock frequency	Master full duplex/receiver mode, $2.7 V < V_{DD} < 3.6 V$ SPI1/4/5	-	-	42	MHz
		Master full duplex/receiver mode, $3.0 V < V_{DD} < 3.6 V$ SPI1/4/5	-	-	50	
		Master transmitter mode $1.7 V < V_{DD} < 3.6 V$ SPI1/4/5	-	-	50	
		Master mode $1.7 V < V_{DD} < 3.6 V$ SPI1/2/3/4/5	-	-	25	
		Slave transmitter/full duplex mode $2.7 V < V_{DD} < 3.6 V$ SPI1/4/5	-	-	38 ⁽²⁾	
		Slave receiver mode, $1.8 V < V_{DD} < 3.6 V$ SPI1/4/5	-	-	50	
		Slave mode, $1.8 V < V_{DD} < 3.6 V$ SPI1/2/3/4/5	-	-	25	
Duty(SCK)	Duty cycle of SPI clock frequency	Slave mode	30	50	70	%
$t_{w(SCKH)}$ $t_{w(SCKL)}$	SCK high and low time	Master mode, SPI presc = 2	$T_{PCLK} - 1.5$	T_{PCLK}	$T_{PCLK} + 1.5$	ns
$t_{su(NSS)}$	NSS setup time	Slave mode, SPI presc = 2	$3T_{PCLK}$	-	-	ns
$t_{h(NSS)}$	NSS hold time	Slave mode, SPI presc = 2	$2T_{PCLK}$	-	-	ns
$t_{su(MI)}$	Data input setup time	Master mode	4	-	-	ns
$t_{su(SI)}$		Slave mode	2.5	-	-	ns
$t_{h(MI)}$	Data input hold time	Master mode	7.5	-	-	ns
$t_{h(SI)}$		Slave mode	3.5	-	-	ns

Table 64. SPI dynamic characteristics⁽¹⁾ (continued)

Symbol	Parameter	Conditions	Min	Typ	Max	Unit
$t_{a(SO)}$	Data output access time	Slave mode	7	-	21	ns
$t_{dis(SO)}$	Data output disable time	Slave mode	5	-	12	ns
$t_{v(SO)}$	Data output valid time	Slave mode (after enable edge), 2.7 V < V_{DD} < 3.6 V	-	11	13	ns
		Slave mode (after enable edge), 1.7 V < V_{DD} < 3.6 V	-	11	18.5	ns
$t_{h(SO)}$	Data output hold time	Slave mode (after enable edge), 1.7 V < V_{DD} < 3.6 V	8	-	-	ns
$t_{v(MO)}$	Data output valid time	Master mode (after enable edge)	-	4	6	ns
$t_{h(MO)}$	Data output hold time	Master mode (after enable edge)	0	-	-	ns

1. Guaranteed by characterization.
2. Maximum frequency in Slave transmitter mode is determined by the sum of $t_{v(SO)}$ and $t_{su(MI)}$ which has to fit into SCK low or high phase preceding the SCK sampling edge. This value can be achieved when the SPI communicates with a master having $t_{su(MI)} = 0$ while Duty(SCK) = 50%

Figure 32. SPI timing diagram - slave mode and CPHA = 0

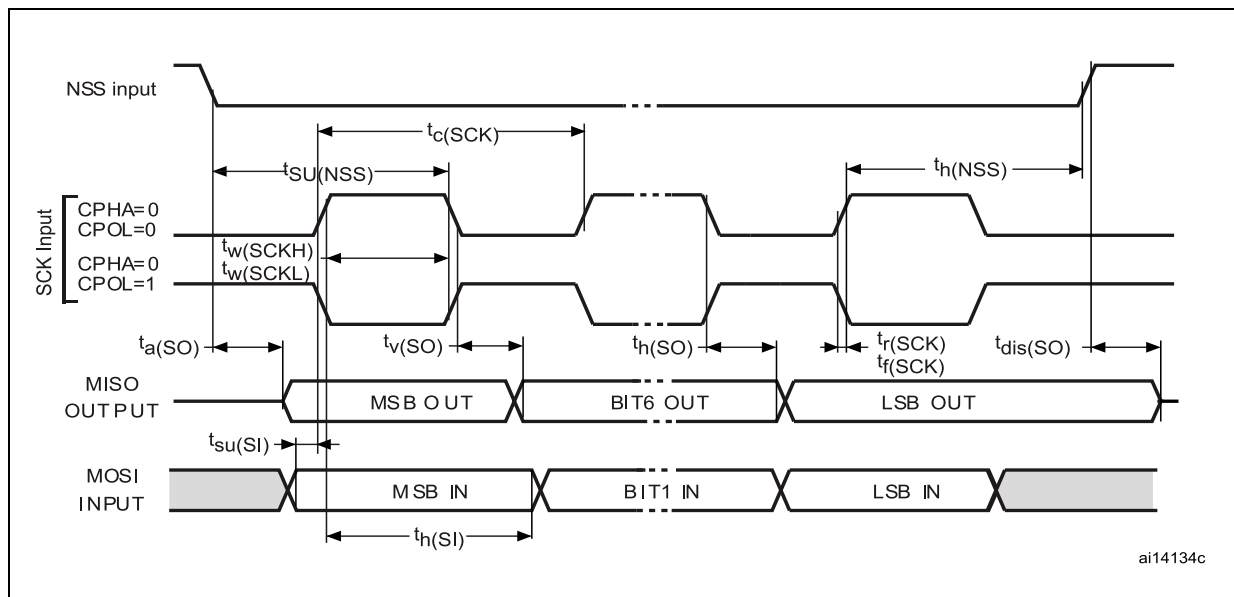

ai14134c

Figure 33. SPI timing diagram - slave mode and CPHA = 1⁽¹⁾

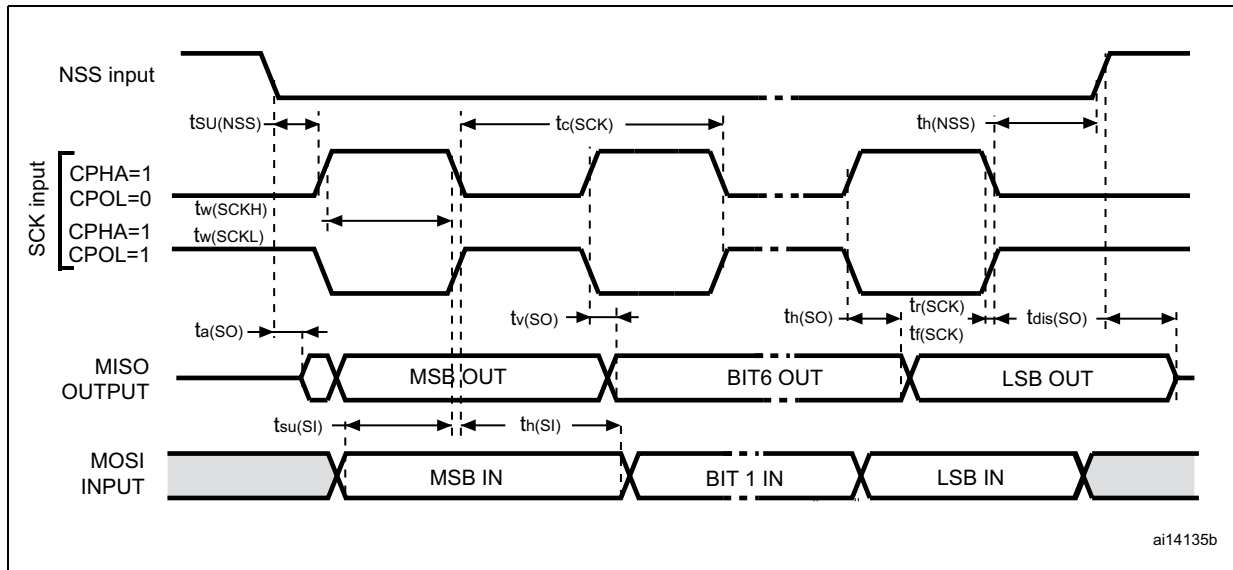
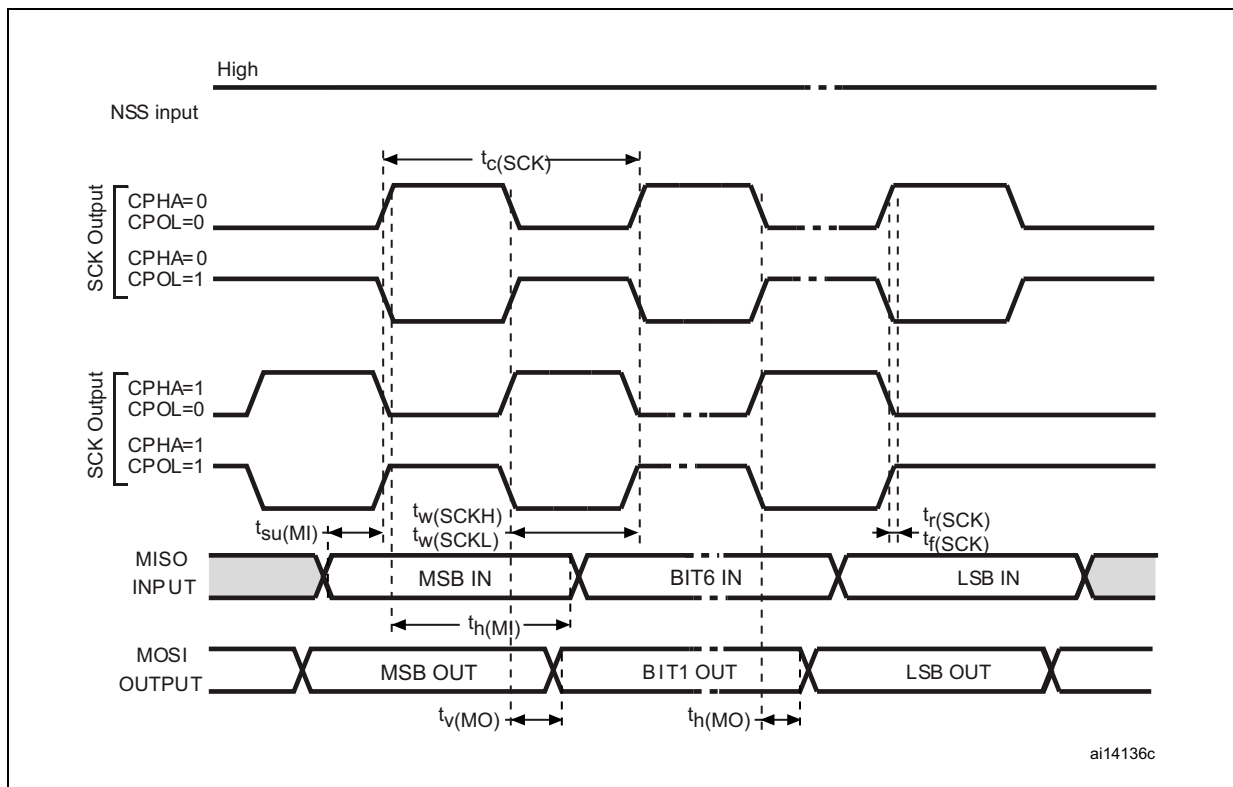

Figure 34. SPI timing diagram - master mode⁽¹⁾



I²S interface characteristics

Unless otherwise specified, the parameters given in [Table 65](#) for the I²S interface are derived from tests performed under the ambient temperature, f_{PCLKX} frequency and V_{DD} supply voltage conditions summarized in [Table 15](#), with the following configuration:

- Output speed is set to OSPEEDRy[1:0] = 10
- Capacitive load C = 30 pF
- Measurement points are done at CMOS levels: 0.5V_{DD}

Refer to [Section 6.3.16: I/O port characteristics](#) for more details on the input/output alternate function characteristics (CK, SD, WS).

Table 65. I²S dynamic characteristics⁽¹⁾

Symbol	Parameter	Conditions	Min	Max	Unit
f _{MCK}	I2S Main clock output	-	256x8K	256xFs ⁽²⁾	MHz
f _{CK}	I2S clock frequency	Master data: 32 bits	-	64xFs	MHz
		Slave data: 32 bits	-	64xFs	
D _{CK}	I2S clock frequency duty cycle	Slave receiver	30	70	%
t _{v(WS)}	WS valid time	Master mode	0	7	ns
t _{h(WS)}	WS hold time	Master mode	1.5	-	
t _{su(WS)}	WS setup time	Slave mode	1.5	-	
t _{h(WS)}	WS hold time	Slave mode	3	-	
t _{su(SD_MR)}	Data input setup time	Master receiver	1	-	
t _{su(SD_SR)}		Slave receiver	2.5	-	
t _{h(SD_MR)}	Data input hold time	Master receiver	7	-	
t _{h(SD_SR)}		Slave receiver	2.5	-	
t _{v(SD_ST)}	Data output valid time	Slave transmitter (after enable edge)	-	20	
t _{v(SD_MT)}		Master transmitter (after enable edge)	-	6	
t _{h(SD_ST)}	Data output hold time	Slave transmitter (after enable edge)	8	-	
t _{h(SD_MT)}		Master transmitter (after enable edge)	2	-	

1. Guaranteed by characterization.
2. The maximum value of 256xFs is 50 MHz (APB1 maximum frequency).

Note: Refer to the I2S section of RM0401 reference manual for more details on the sampling frequency (F_S).

f_{MCK}, f_{CK}, and D_{CK} values reflect only the digital peripheral behavior. The values of these parameters might be slightly impacted by the source clock precision. D_{CK} depends mainly on the value of ODD bit. The digital contribution leads to a minimum value of (I2SDIV/(2*I2SDIV+ODD)) and a maximum value of (I2SDIV+ODD)/(2*I2SDIV+ODD). F_S maximum value is supported for each mode/condition.

Figure 35. I²S slave timing diagram (Philips protocol)⁽¹⁾

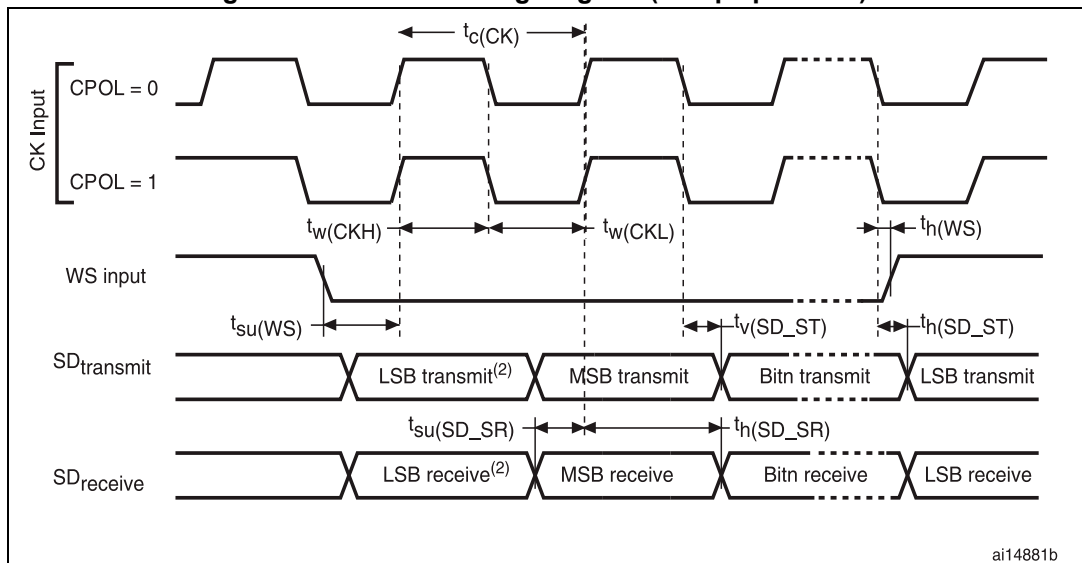

1. LSB transmit/receive of the previously transmitted byte. No LSB transmit/receive is sent before the first byte.

Figure 36. I²S master timing diagram (Philips protocol)⁽¹⁾

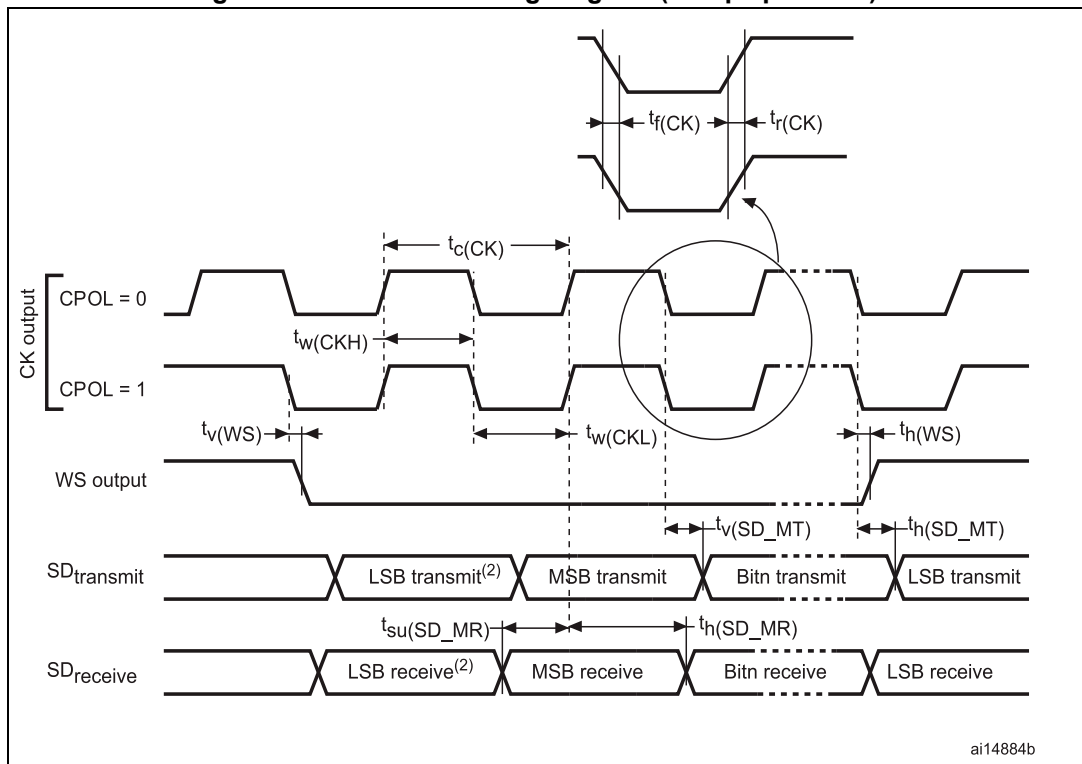

1. LSB transmit/receive of the previously transmitted byte. No LSB transmit/receive is sent before the first byte.

6.3.20 12-bit ADC characteristics

Unless otherwise specified, the parameters given in [Table 66](#) are derived from tests performed under the ambient temperature, f_{PCLK2} frequency and V_{DDA} supply voltage conditions summarized in [Table 15](#).

Table 66. ADC characteristics

Symbol	Parameter	Conditions	Min	Typ	Max	Unit
V_{DDA}	Power supply	$V_{DDA} - V_{REF+} < 1.2\text{ V}$	1.7 ⁽¹⁾	-	3.6	V
V_{REF+}	Positive reference voltage		1.7 ⁽¹⁾	-	V_{DDA}	
V_{REF-}	Negative reference voltage	-	-	0	-	
f_{ADC}	ADC clock frequency	$V_{DDA} = 1.7^{(1)}\text{ to }2.4\text{ V}$	0.6	15	18	MHz
		$V_{DDA} = 2.4\text{ to }3.6\text{ V}$	0.6	30	36	MHz
$f_{TRIG}^{(2)}$	External trigger frequency	$f_{ADC} = 30\text{ MHz}$, 12-bit resolution	-	-	1764	kHz
		-	-	-	17	$1/f_{ADC}$
V_{AIN}	Conversion voltage range ⁽³⁾	-	0 (V_{SSA} or V_{REF-} tied to ground)	-	V_{REF+}	V
$R_{AIN}^{(2)}$	External input impedance	See Equation 1 for details	-	-	50	$\kappa\Omega$
$R_{ADC}^{(2)(4)}$	Sampling switch resistance	-	-	-	6	$\kappa\Omega$
$C_{ADC}^{(2)}$	Internal sample and hold capacitor	-	-	4	7	pF
$t_{lat}^{(2)}$	Injection trigger conversion latency	$f_{ADC} = 30\text{ MHz}$	-	-	0.100	μs
		-	-	-	3 ⁽⁵⁾	$1/f_{ADC}$
$t_{latr}^{(2)}$	Regular trigger conversion latency	$f_{ADC} = 30\text{ MHz}$	-	-	0.067	μs
		-	-	-	2 ⁽⁵⁾	$1/f_{ADC}$
$t_S^{(2)}$	Sampling time	$f_{ADC} = 30\text{ MHz}$	0.100	-	16	μs
		-	3	-	480	$1/f_{ADC}$
$t_{STAB}^{(2)}$	Power-up time	-	-	2	3	μs
$t_{CONV}^{(2)}$	Total conversion time (including sampling time)	$f_{ADC} = 30\text{ MHz}$ 12-bit resolution	0.50	-	16.40	μs
		$f_{ADC} = 30\text{ MHz}$ 10-bit resolution	0.43	-	16.34	μs
		$f_{ADC} = 30\text{ MHz}$ 8-bit resolution	0.37	-	16.27	μs
		$f_{ADC} = 30\text{ MHz}$ 6-bit resolution	0.30	-	16.20	μs
		9 to 492 (t_S for sampling +n-bit resolution for successive approximation)	-	-	-	-

Table 66. ADC characteristics (continued)

Symbol	Parameter	Conditions	Min	Typ	Max	Unit
$f_S^{(2)}$	Sampling rate ($f_{ADC} = 30$ MHz, and $t_S = 3$ ADC cycles)	12-bit resolution Single ADC	-	-	2	MspS
		12-bit resolution Interleave Dual ADC mode	-	-	3.75	MspS
		12-bit resolution Interleave Triple ADC mode	-	-	6	MspS
$I_{VREF+}^{(2)}$	ADC V_{REF} DC current consumption in conversion mode	-	-	300	500	μ A
$I_{VDDA}^{(2)}$	ADC V_{DDA} DC current consumption in conversion mode	-	-	1.6	1.8	mA

- V_{DDA} minimum value of 1.7 V is possible with the use of an external power supply supervisor (refer to [Section 3.14.2: Internal reset OFF](#)).
- Guaranteed by characterization.
- V_{REF+} is internally connected to V_{DDA} and V_{REF-} is internally connected to V_{SSA} .
- R_{ADC} maximum value is given for $V_{DD}=1.7$ V, and minimum value for $V_{DD}=3.3$ V.
- For external triggers, a delay of $1/f_{PCLK2}$ must be added to the latency specified in [Table 66](#).

Equation 1: R_{AIN} max formula

$$R_{AIN} = \frac{(k - 0.5)}{f_{ADC} \times C_{ADC} \times \ln(2^{N+2})} - R_{ADC}$$

The formula above ([Equation 1](#)) is used to determine the maximum external impedance allowed for an error below 1/4 of LSB. N = 12 (from 12-bit resolution) and k is the number of sampling periods defined in the ADC_SMPR1 register.

Table 67. ADC accuracy at $f_{ADC} = 18$ MHz⁽¹⁾

Symbol	Parameter	Test conditions	Typ	Max ⁽²⁾	Unit
ET	Total unadjusted error	$f_{ADC} = 18$ MHz $V_{DDA} = 1.7$ to 3.6 V $V_{REF} = 1.7$ to 3.6 V $V_{DDA} - V_{REF} < 1.2$ V	± 3	± 4	LSB
EO	Offset error		± 2	± 3	
EG	Gain error		± 1	± 3	
ED	Differential linearity error		± 1	± 2	
EL	Integral linearity error		± 2	± 3	

- Better performance could be achieved in restricted V_{DD} , frequency and temperature ranges.
- Guaranteed by characterization.

Table 68. ADC accuracy at $f_{ADC} = 30\text{ MHz}^{(1)}$

Symbol	Parameter	Test conditions	Typ	Max ⁽²⁾	Unit
ET	Total unadjusted error	$f_{ADC} = 30\text{ MHz}$, $R_{AIN} < 10\text{ k}\Omega$, $V_{DDA} = 2.4\text{ to }3.6\text{ V}$, $V_{REF} = 1.7\text{ to }3.6\text{ V}$, $V_{DDA} - V_{REF} < 1.2\text{ V}$	± 2	± 5	LSB
EO	Offset error		± 1.5	± 2.5	
EG	Gain error		± 1.5	± 4	
ED	Differential linearity error		± 1	± 2	
EL	Integral linearity error		± 1.5	± 3	

1. Better performance could be achieved in restricted V_{DD} , frequency and temperature ranges.
2. Guaranteed by characterization.

Table 69. ADC accuracy at $f_{ADC} = 36\text{ MHz}^{(1)}$

Symbol	Parameter	Test conditions	Typ	Max ⁽²⁾	Unit
ET	Total unadjusted error	$f_{ADC} = 36\text{ MHz}$, $V_{DDA} = 2.4\text{ to }3.6\text{ V}$, $V_{REF} = 1.7\text{ to }3.6\text{ V}$, $V_{DDA} - V_{REF} < 1.2\text{ V}$	± 4	± 7	LSB
EO	Offset error		± 2	± 3	
EG	Gain error		± 3	± 6	
ED	Differential linearity error		± 2	± 3	
EL	Integral linearity error		± 3	± 6	

1. Better performance could be achieved in restricted V_{DD} , frequency and temperature ranges.
2. Guaranteed by characterization.

Table 70. ADC dynamic accuracy at $f_{ADC} = 18\text{ MHz}$ - limited test conditions⁽¹⁾

Symbol	Parameter	Test conditions	Min	Typ	Max	Unit
ENOB	Effective number of bits	$f_{ADC} = 18\text{ MHz}$ $V_{DDA} = V_{REF+} = 1.7\text{ V}$ Input Frequency = 20 KHz Temperature = 25 °C	10.3	10.4	-	bits
SINAD	Signal-to-noise and distortion ratio		64	64.2	-	dB
SNR	Signal-to-noise ratio		64	65	-	
THD	Total harmonic distortion		-	-72	-67	

1. Guaranteed by characterization.

Table 71. ADC dynamic accuracy at $f_{ADC} = 36\text{ MHz}$ - limited test conditions⁽¹⁾

Symbol	Parameter	Test conditions	Min	Typ	Max	Unit
ENOB	Effective number of bits	$f_{ADC} = 36\text{ MHz}$ $V_{DDA} = V_{REF+} = 3.3\text{ V}$ Input Frequency = 20 KHz Temperature = 25 °C	10.6	10.8	-	bits
SINAD	Signal-to noise and distortion ratio		66	67	-	dB
SNR	Signal-to noise ratio		64	68	-	
THD	Total harmonic distortion		-	-72	-70	

1. Guaranteed by characterization.

Note: ADC accuracy vs. negative injection current: injecting a negative current on any analog input pins should be avoided as this significantly reduces the accuracy of the conversion being performed on another analog input. It is recommended to add a Schottky diode (pin to ground) to analog pins which may potentially inject negative currents.

Any positive injection current within the limits specified for $I_{INJ(PIN)}$ and $\Sigma I_{INJ(PIN)}$ in [Section 6.3.16](#) does not affect the ADC accuracy.

Figure 37. ADC accuracy characteristics

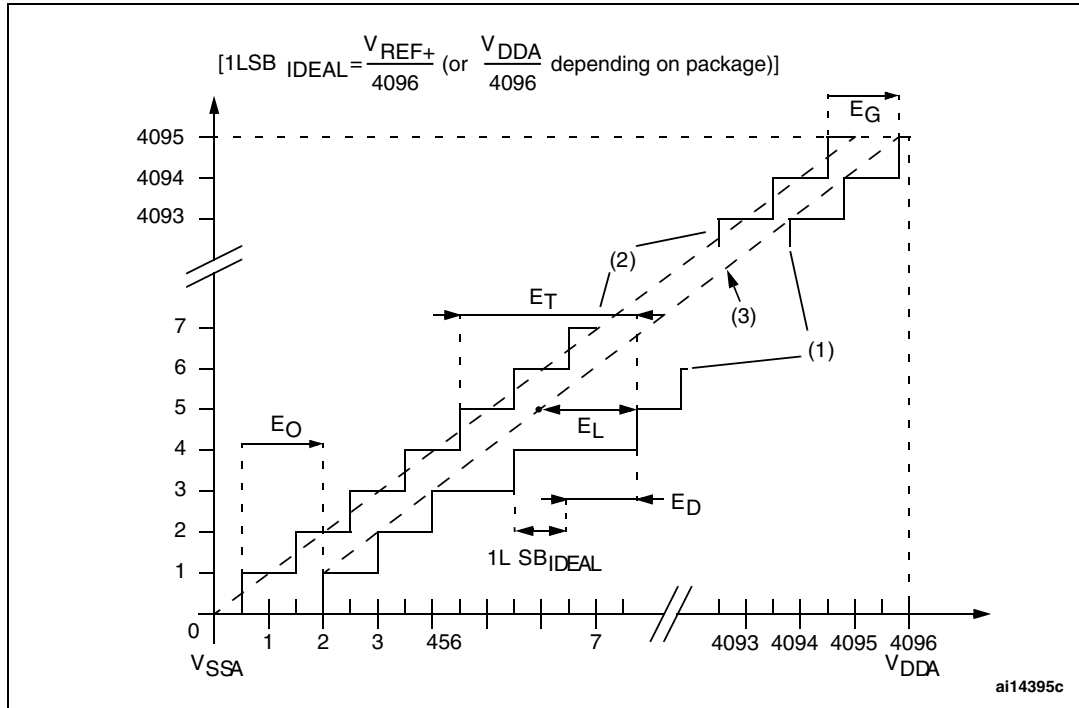

1. See also [Table 68](#).
2. Example of an actual transfer curve.
3. Ideal transfer curve.
4. End point correlation line.
5. E_T = Total Unadjusted Error: maximum deviation between the actual and the ideal transfer curves.
 E_O = Offset Error: deviation between the first actual transition and the first ideal one.
 E_G = Gain Error: deviation between the last ideal transition and the last actual one.
 E_D = Differential Linearity Error: maximum deviation between actual steps and the ideal one.
 E_L = Integral Linearity Error: maximum deviation between any actual transition and the end point correlation line.

Figure 38. Typical connection diagram using the ADC

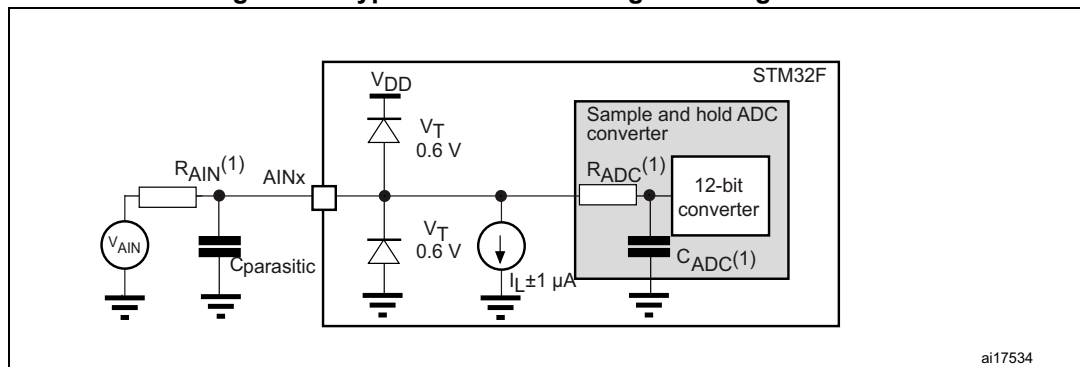

1. Refer to [Table 66](#) for the values of R_{AIN} , R_{ADC} and C_{ADC} .
2. $C_{parasitic}$ represents the capacitance of the PCB (dependent on soldering and PCB layout quality) plus the pad capacitance (roughly 5 pF). A high $C_{parasitic}$ value downgrades conversion accuracy. To remedy this, f_{ADC} should be reduced.

General PCB design guidelines

Power supply decoupling should be performed as shown in *Figure 39*. The 10 nF capacitors should be ceramic (good quality). They should be placed as close as possible to the chip.

Figure 39. Power supply and reference decoupling

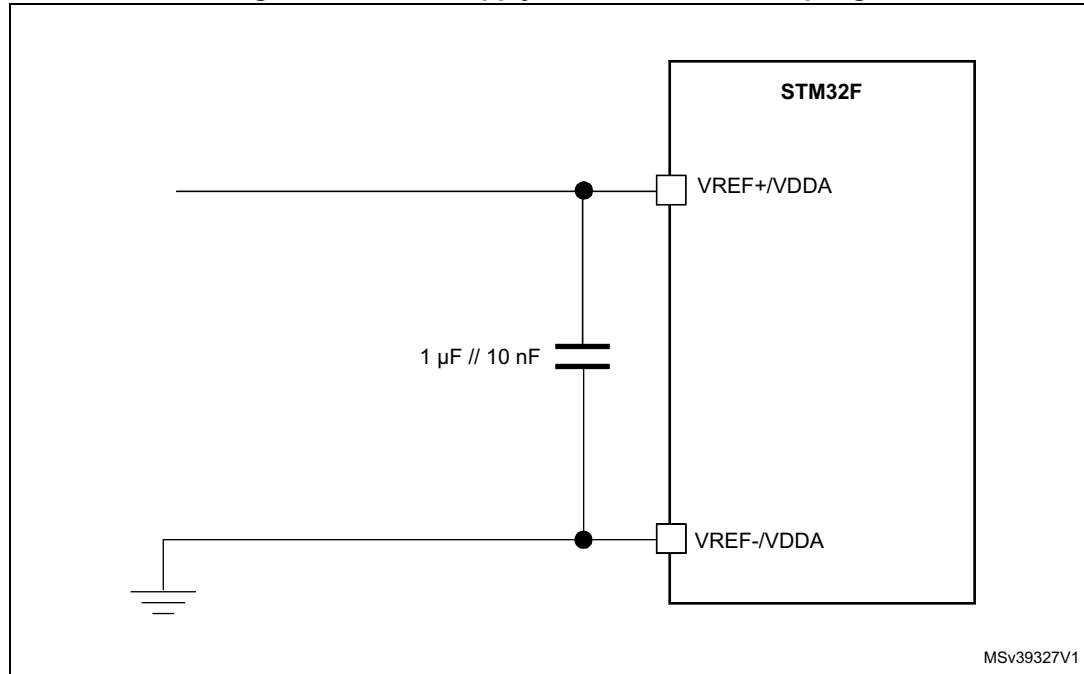

6.3.21 Temperature sensor characteristics

Table 72. Temperature sensor characteristics

Symbol	Parameter	Min	Typ	Max	Unit
$T_L^{(1)}$	V_{SENSE} linearity with temperature	-	± 1	± 2	$^{\circ}C$
Avg_Slope ⁽¹⁾	Average slope	-	2.5	-	mV/ $^{\circ}C$
$V_{25}^{(1)}$	Voltage at 25 $^{\circ}C$	-	0.76	-	V
$t_{START}^{(2)}$	Startup time	-	6	10	μs
$T_{S_temp}^{(2)}$	ADC sampling time when reading the temperature (1 $^{\circ}C$ accuracy)	10	-	-	μs

1. Guaranteed by characterization.
2. Guaranteed by design.

Table 73. Temperature sensor calibration values

Symbol	Parameter	Memory address
TS_CAL1	TS ADC raw data acquired at temperature of 30 $^{\circ}C$, $V_{DDA} = 3.3 V$	0x1FFF 7A2C - 0x1FFF 7A2D
TS_CAL2	TS ADC raw data acquired at temperature of 110 $^{\circ}C$, $V_{DDA} = 3.3 V$	0x1FFF 7A2E - 0x1FFF 7A2F

6.3.22 V_{BAT} monitoring characteristics

Table 74. V_{BAT} monitoring characteristics

Symbol	Parameter	Min	Typ	Max	Unit
R	Resistor bridge for V_{BAT}	-	50	-	K Ω
Q	Ratio on V_{BAT} measurement	-	4	-	-
$E_r^{(1)}$	Error on Q	-1	-	+1	%
$T_{S_vbat}^{(2)}$	ADC sampling time when reading the V_{BAT} 1 mV accuracy	5	-	-	μ s

1. Guaranteed by design.
2. Shortest sampling time can be determined in the application by multiple iterations.

6.3.23 Embedded reference voltage

The parameters given in [Table 75](#) are derived from tests performed under ambient temperature and V_{DD} supply voltage conditions summarized in [Table 15](#).

Table 75. Embedded internal reference voltage

Symbol	Parameter	Conditions	Min	Typ	Max	Unit
V_{REFINT}	Internal reference voltage	$-40\text{ }^\circ\text{C} < T_A < +125\text{ }^\circ\text{C}$	1.18	1.21	1.24	V
$T_{S_vrefint}^{(1)}$	ADC sampling time when reading the internal reference voltage	-	10	-	-	μ s
$V_{RERINT_s}^{(2)}$	Internal reference voltage spread over the temperature range	$V_{DD} = 3\text{ V} \pm 10\text{ mV}$	-	3	5	mV
$T_{Coef}^{(2)}$	Temperature coefficient	-	-	30	50	ppm/ $^\circ\text{C}$
$t_{START}^{(2)}$	Startup time	-	-	6	10	μ s

1. Shortest sampling time can be determined in the application by multiple iterations.
2. Guaranteed by design

Table 76. Internal reference voltage calibration values

Symbol	Parameter	Memory address
V_{REFIN_CAL}	Raw data acquired at temperature of $30\text{ }^\circ\text{C}$ $V_{DDA} = 3.3\text{ V}$	0x1FFF 7A2A - 0x1FFF 7A2B

6.3.24 DAC electrical characteristics

Table 77. DAC characteristics

Symbol	Parameter	Conditions	Min	Typ	Max	Unit	Comments	
V_{DDA}	Analog supply voltage	-	1.7 ⁽¹⁾	-	3.6	V	-	
V_{REF+}	Reference supply voltage	-	1.7 ⁽¹⁾	-	3.6	V	$V_{REF+} \leq V_{DDA}$	
V_{SSA}	Ground	-	0	-	0	V	-	
$R_{LOAD}^{(2)}$	Resistive load	DAC output buffer ON	R_{LOAD} connected to V_{SSA}	5	-	-	k Ω	-
			R_{LOAD} connected to V_{DDA}	25	-	-	k Ω	-
$R_O^{(2)}$	Impedance output with buffer OFF	-	-	-	15	k Ω	When the buffer is OFF, the Minimum resistive load between DAC_OUT and V_{SS} to have a 1% accuracy is 1.5 M Ω	
$C_{LOAD}^{(2)}$	Capacitive load	-	-	-	50	pF	Maximum capacitive load at DAC_OUT pin (when the buffer is ON).	
DAC_OUT min ⁽²⁾	Lower DAC_OUT voltage with buffer ON	-	0.2	-	-	V	It gives the maximum output excursion of the DAC. It corresponds to 12-bit input code (0x0E0) to (0xF1C) at $V_{REF+} = 3.6$ V and (0x1C7) to (0xE38) at $V_{REF+} = 1.7$ V	
DAC_OUT max ⁽²⁾	Higher DAC_OUT voltage with buffer ON	-	-	-	$V_{DDA} - 0.2$	V		
DAC_OUT min ⁽²⁾	Lower DAC_OUT voltage with buffer OFF	-	-	0.5	-	mV	It gives the maximum output excursion of the DAC.	
DAC_OUT max ⁽²⁾	Higher DAC_OUT voltage with buffer OFF	-	-	-	$V_{REF+} - 1LSB$	V		
$I_{VREF+}^{(4)}$	DAC DC V_{REF} current consumption in quiescent mode (Standby mode)	-	-	170	240	μA	With no load, worst code (0x800) at $V_{REF+} = 3.6$ V in terms of DC consumption on the inputs	
		-	-	50	75		With no load, worst code (0xF1C) at $V_{REF+} = 3.6$ V in terms of DC consumption on the inputs	

Table 77. DAC characteristics (continued)

Symbol	Parameter	Conditions	Min	Typ	Max	Unit	Comments
$I_{DDA}^{(4)}$	DAC DC VDDA current consumption in quiescent mode ⁽³⁾	-	-	280	380	μA	With no load, middle code (0x800) on the inputs
		-	-	475	625	μA	With no load, worst code (0xF1C) at $V_{REF+} = 3.6\text{ V}$ in terms of DC consumption on the inputs
DNL ⁽⁴⁾	Differential non linearity Difference between two consecutive code-1LSB)	-	-	-	± 0.5	LSB	Given for the DAC in 10-bit configuration.
		-	-	-	± 2	LSB	Given for the DAC in 12-bit configuration.
INL ⁽⁴⁾	Integral non linearity (difference between measured value at Code i and the value at Code i on a line drawn between Code 0 and last Code 1023)	-	-	-	± 1	LSB	Given for the DAC in 10-bit configuration.
		-	-	-	± 4	LSB	Given for the DAC in 12-bit configuration.
Offset ⁽⁴⁾	Offset error (difference between measured value at Code (0x800) and the ideal value = $V_{REF+}/2$)	-	-	-	± 10	mV	Given for the DAC in 12-bit configuration
		-	-	-	± 3	LSB	Given for the DAC in 10-bit at $V_{REF+} = 3.6\text{ V}$
		-	-	-	± 12	LSB	Given for the DAC in 12-bit at $V_{REF+} = 3.6\text{ V}$
Gain error ⁽⁴⁾	Gain error	-	-	-	± 0.5	%	Given for the DAC in 12-bit configuration
$t_{SETTLING}^{(4)}$	Total Harmonic Distortion Buffer ON	-	-	3	6	μs	$C_{LOAD} \leq 50\text{ pF}$, $R_{LOAD} \geq 5\text{ k}\Omega$
THD ⁽⁴⁾	-	-	-	-	-	dB	$C_{LOAD} \leq 50\text{ pF}$, $R_{LOAD} \geq 5\text{ k}\Omega$
Update rate ⁽²⁾	Max frequency for a correct DAC_OUT change when small variation in the input code (from code i to i+1LSB)	-	-	-	1	MS/s	$C_{LOAD} \leq 50\text{ pF}$, $R_{LOAD} \geq 5\text{ k}\Omega$

Table 77. DAC characteristics (continued)

Symbol	Parameter	Conditions	Min	Typ	Max	Unit	Comments
$t_{WAKEUP}^{(4)}$	Wakeup time from off state (Setting the ENx bit in the DAC Control register)	-	-	6.5	10	μs	$C_{LOAD} \leq 50 \text{ pF}$, $R_{LOAD} \geq 5 \text{ k}\Omega$ input code between lowest and highest possible ones.
PSRR+	Power supply rejection ratio (to V_{DDA}) (static DC measurement)	-	-	-67	-40	dB	No R_{LOAD} , $C_{LOAD} = 50 \text{ pF}$

- V_{DDA} minimum value of 1.7 V is obtained with the use of an external power supply supervisor (refer to [Section 3.15.2: Internal reset OFF](#)).
- Guaranteed by design.
- The quiescent mode corresponds to a state where the DAC maintains a stable output level to ensure that no dynamic consumption occurs.
- Guaranteed based on test during characterization.

Figure 40. 12-bit buffered/non-buffered DAC

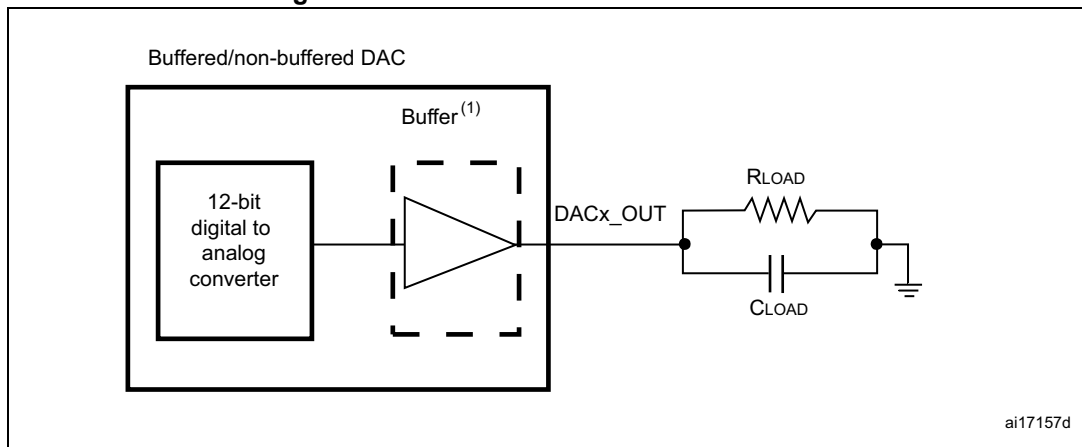

- The DAC integrates an output buffer that can be used to reduce the output impedance and to drive external loads directly without the use of an external operational amplifier. The buffer can be bypassed by configuring the BOFFx bit in the DAC_CR register.

6.3.25 RTC characteristics

Table 78. RTC characteristics

Symbol	Parameter	Conditions	Min	Max
-	$f_{PCLK1}/RTCCLK$ frequency ratio	Any read/write operation from/to an RTC register	4	-

7 Package information

In order to meet environmental requirements, ST offers these devices in different grades of ECOPACK® packages, depending on their level of environmental compliance. ECOPACK® specifications, grade definitions and product status are available at: www.st.com. ECOPACK® is an ST trademark.

7.1 WLCSP36 package information

Figure 41. WLCSP36 - 36-pin, 2.553 x 2.579 mm, 0.4 mm pitch wafer level chip scale package outline

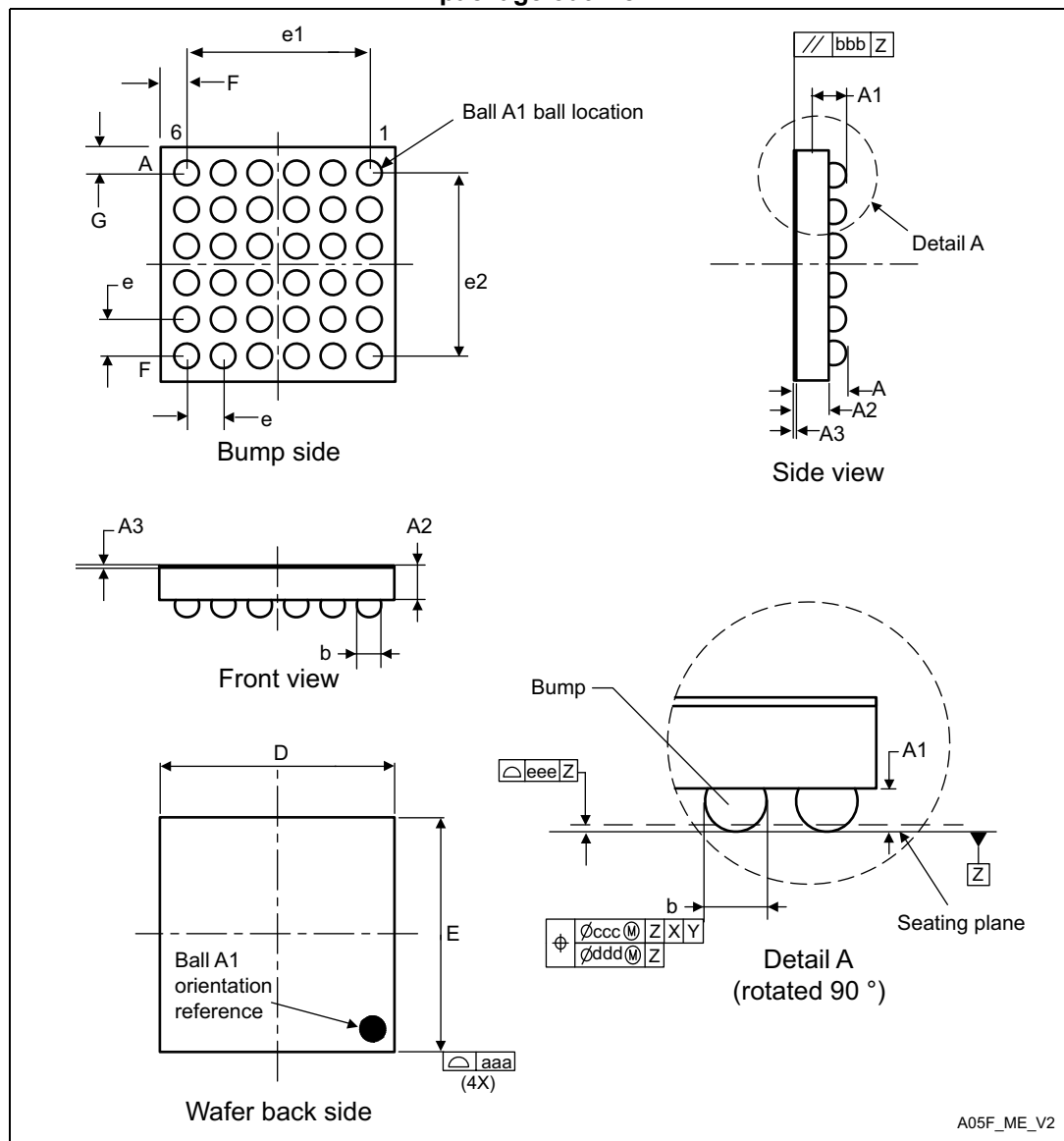

1. Drawing is not to scale.

Table 79. WLCSP36 - 36-pin, 2.553 x 2.579 mm, 0.4 mm pitch wafer level chip scale package mechanical data

Symbol	millimeters			inches ⁽¹⁾		
	Min	Typ	Max	Min	Typ	Max
A	0.525	0.555	0.585	0.0207	0.0219	0.0230
A1	-	0.170	-	-	0.0069	-
A2	-	0.380	-	-	0.0150	-
A3 ⁽²⁾	-	0.025	-	-	0.0010	-
b ⁽³⁾	0.220	0.250	0.280	0.0087	0.0098	0.0110
D	2.518	2.553	2.588	0.1012	0.1026	0.1039
E	2.544	2.579	2.614	0.1050	0.1064	0.1078
e	-	0.400	-	-	0.0157	-
e1	-	2.000	-	-	0.0787	-
e2	-	2.000	-	-	0.0787	-
F	-	0.2765	-	-	0.0119	-
G	-	0.2895	-	-	0.0138	-
aaa	-	-	0.100	-	-	0.0039
bbb	-	-	0.100	-	-	0.0039
ccc	-	-	0.100	-	-	0.0039
ddd	-	-	0.050	-	-	0.0020
eee	-	-	0.050	-	-	0.0020

1. Values in inches are converted from mm and rounded to 4 decimal digits.
2. Back side coating.
3. Dimension is measured at the maximum bump diameter parallel to primary datum Z.

Figure 42. WLCSP36 - 36-pin, 2.553 x 2.579 mm, 0.4 mm pitch wafer level chip scale package recommended footprint

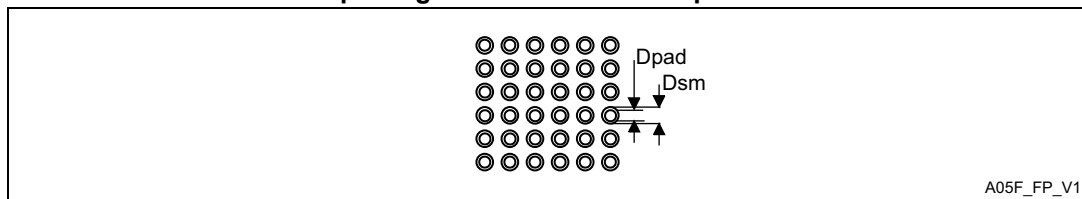

Table 80. WLCSP36 recommended PCB design rules (0.4 mm pitch)

Dimension	Recommended values
Pitch	0.4 mm
Dpad	0.225 mm
Dsm	0.290 mm typ. (depends on the soldermask registration tolerance)
Stencil opening	0.250 mm
Stencil thickness	0.100 mm

WLCSP36 device marking

The following figure gives an example of topside marking orientation versus ball A1 identifier location.

Other optional marking or inset/upset marks, which identify the parts throughout supply chain operations, are not indicated below.

Figure 43. WLCSP36 marking example (package top view)

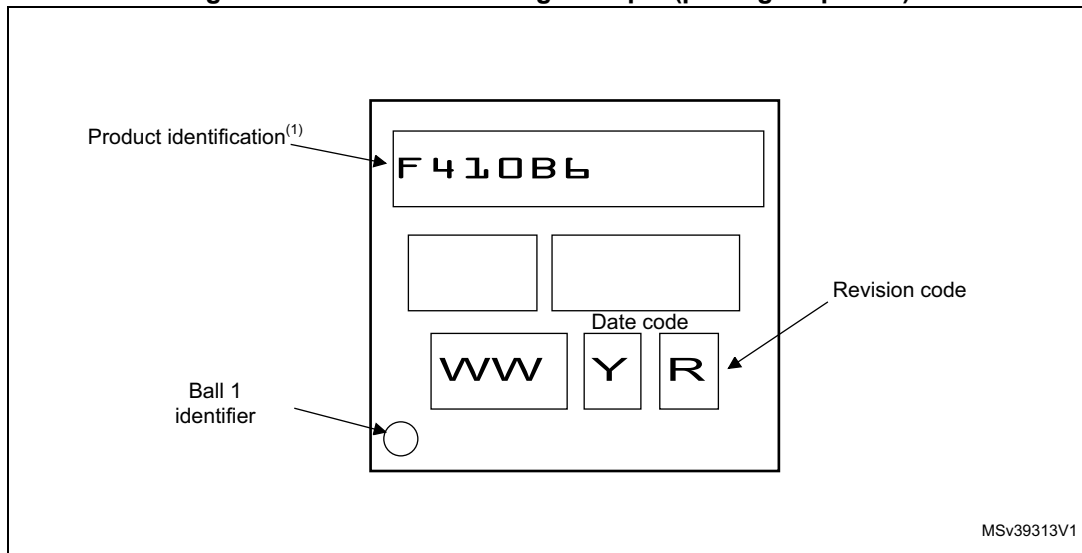

1. Parts marked as “ES”, “E” or accompanied by an Engineering Sample notification letter, are not yet qualified and therefore not yet ready to be used in production and any consequences deriving from such usage will not be at ST charge. In no event, ST will be liable for any customer usage of these engineering samples in production. ST Quality has to be contacted prior to any decision to use these Engineering samples to run qualification activity.

7.2 UFQFPN48 package information

Figure 44. UFQFPN48 - 48-lead, 7x7 mm, 0.5 mm pitch, ultra thin fine pitch quad flat package outline

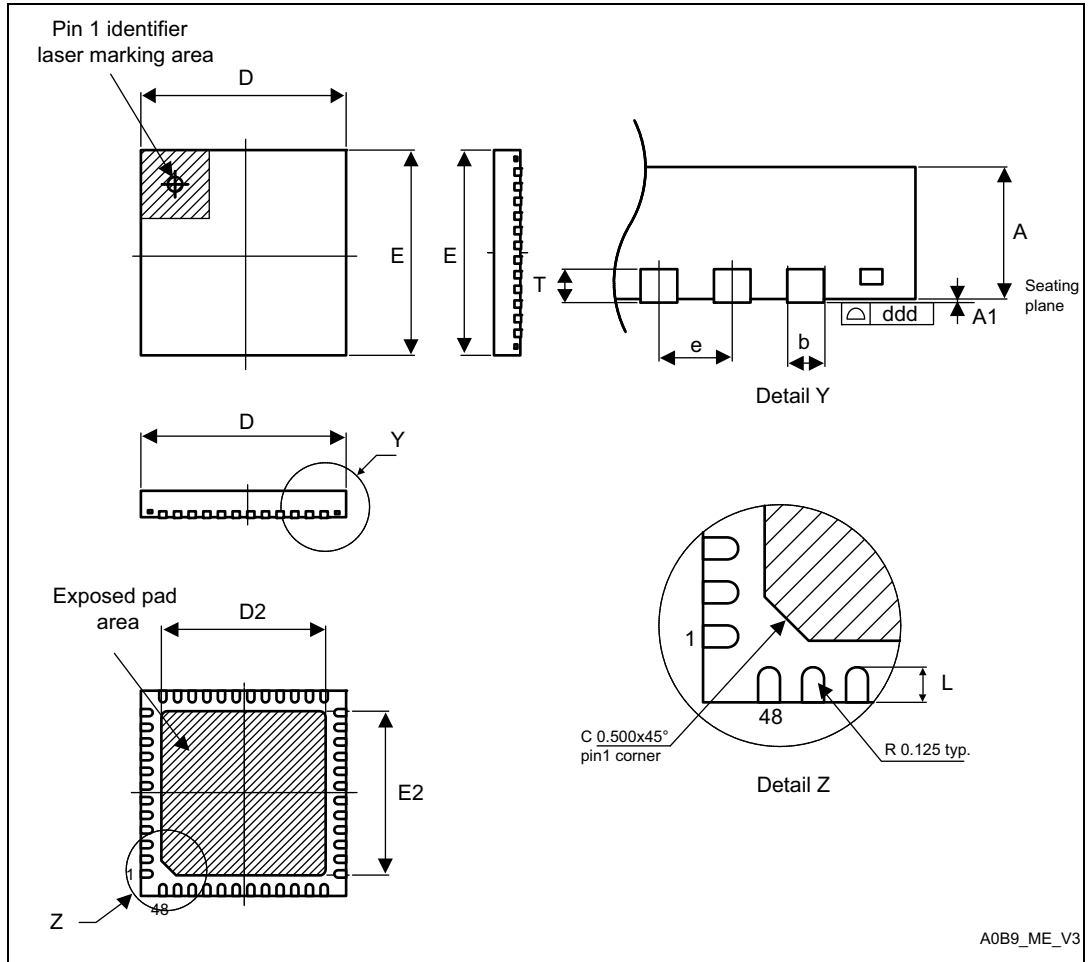

A0B9_ME_V3

1. Drawing is not to scale.
2. All leads/pads should also be soldered to the PCB to improve the lead/pad solder joint life.
3. There is an exposed die pad on the underside of the UFQFPN package. It is recommended to connect and solder this back-side pad to PCB ground.

Table 81. UFQFPN48 - 48-lead, 7x7 mm, 0.5 mm pitch, ultra thin fine pitch quad flat package mechanical data

Symbol	millimeters			inches ⁽¹⁾		
	Min.	Typ.	Max.	Min.	Typ.	Max.
A	0.500	0.550	0.600	0.0197	0.0217	0.0236
A1	0.000	0.020	0.050	0.0000	0.0008	0.0020
D	6.900	7.000	7.100	0.2717	0.2756	0.2795
E	6.900	7.000	7.100	0.2717	0.2756	0.2795
D2	5.500	5.600	5.700	0.2165	0.2205	0.2244
E2	5.500	5.600	5.700	0.2165	0.2205	0.2244
L	0.300	0.400	0.500	0.0118	0.0157	0.0197
T	-	0.152	-	-	0.0060	-
b	0.200	0.250	0.300	0.0079	0.0098	0.0118
e	-	0.500	-	-	0.0197	-
ddd	-	-	0.080	-	-	0.0031

1. Values in inches are converted from mm and rounded to 4 decimal digits.

Figure 45. UFQFPN48 recommended footprint

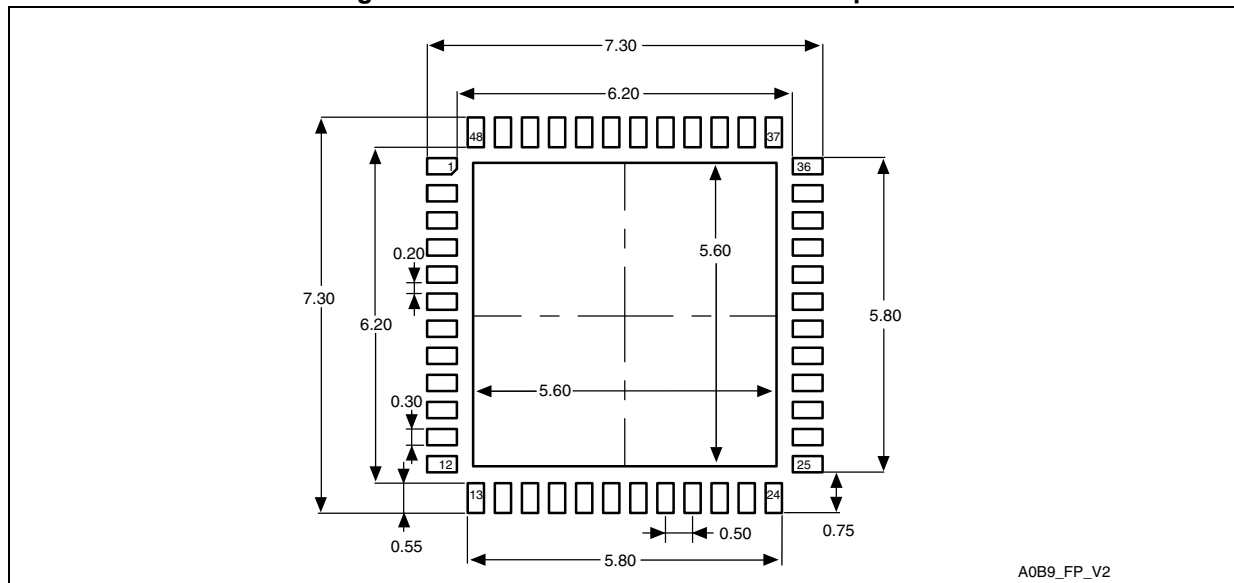

1. Dimensions are in millimeters.

UFQFPN48 device marking

The following figure gives an example of topside marking orientation versus pin 1 identifier location.

Other optional marking or inset/upset marks, which identify the parts throughout supply chain operations, are not indicated below.

Figure 46. UFQFPN48 marking example (package top view)

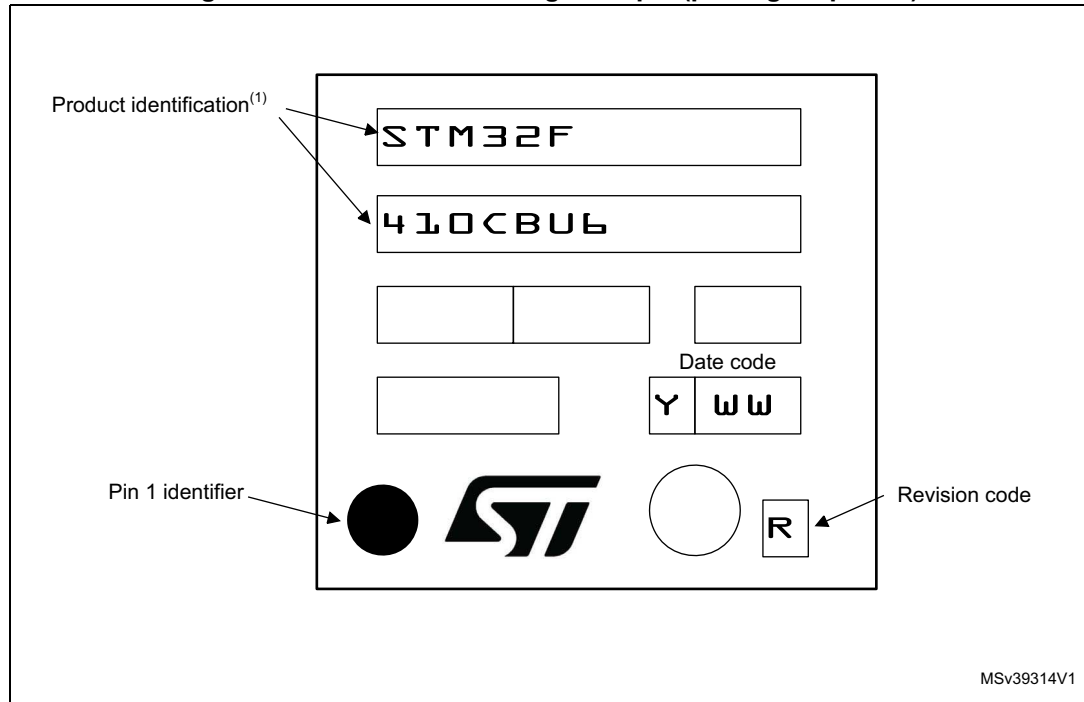

1. Parts marked as “ES”, “E” or accompanied by an Engineering Sample notification letter, are not yet qualified and therefore not yet ready to be used in production and any consequences deriving from such usage will not be at ST charge. In no event, ST will be liable for any customer usage of these engineering samples in production. ST Quality has to be contacted prior to any decision to use these Engineering samples to run qualification activity.

7.3 LQFP48 package information

Figure 47. LQFP48 - 48-pin, 7 x 7 mm low-profile quad flat package outline

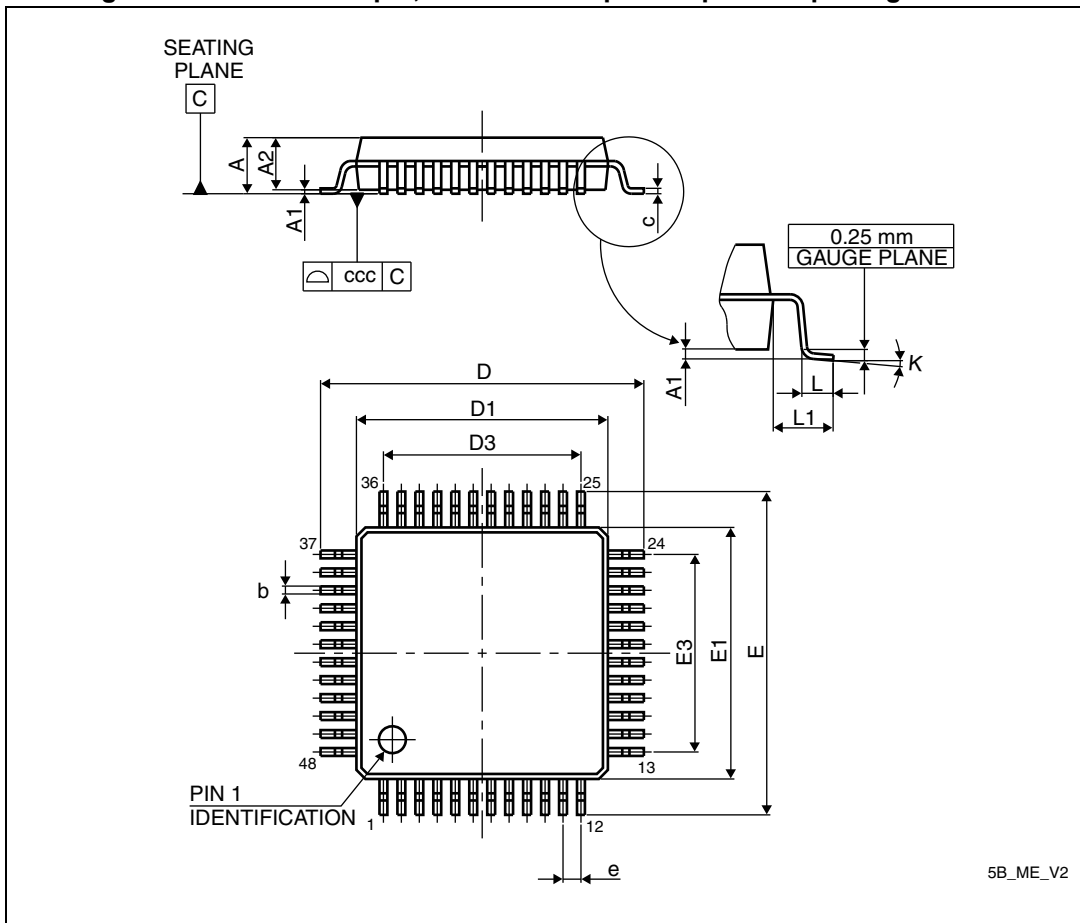

1. Drawing is not to scale.

**Table 82. LQFP48 - 48-pin, 7 x 7 mm low-profile quad flat package
mechanical data**

Symbol	millimeters			inches ⁽¹⁾		
	Min	Typ	Max	Min	Typ	Max
A	-	-	1.600	-	-	0.0630
A1	0.050	-	0.150	0.0020	-	0.0059
A2	1.350	1.400	1.450	0.0531	0.0551	0.0571
b	0.170	0.220	0.270	0.0067	0.0087	0.0106
c	0.090	-	0.200	0.0035	-	0.0079
D	8.800	9.000	9.200	0.3465	0.3543	0.3622
D1	6.800	7.000	7.200	0.2677	0.2756	0.2835
D3	-	5.500	-	-	0.2165	-
E	8.800	9.000	9.200	0.3465	0.3543	0.3622
E1	6.800	7.000	7.200	0.2677	0.2756	0.2835
E3	-	5.500	-	-	0.2165	-
e	-	0.500	-	-	0.0197	-
L	0.450	0.600	0.750	0.0177	0.0236	0.0295
L1	-	1.000	-	-	0.0394	-
k	0°	3.5°	7°	0°	3.5°	7°
ccc	-	-	0.080	-	-	0.0031

1. Values in inches are converted from mm and rounded to 4 decimal digits.

Figure 48. LQFP48 - 48-pin, 7 x 7 mm low-profile quad flat package recommended footprint

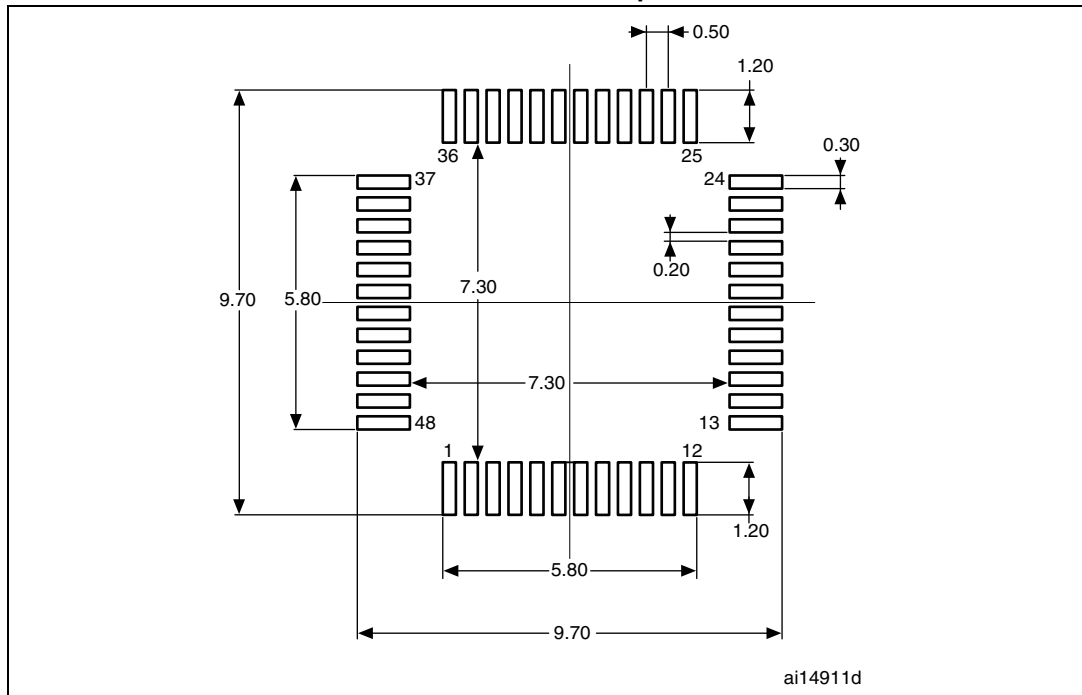

1. Dimensions are expressed in millimeters.

LQFP48 device marking

The following figure gives an example of topside marking orientation versus pin 1 identifier location.

Other optional marking or inset/upset marks, which identify the parts throughout supply chain operations, are not indicated below.

Figure 49. LQFP48 marking example (package top view)

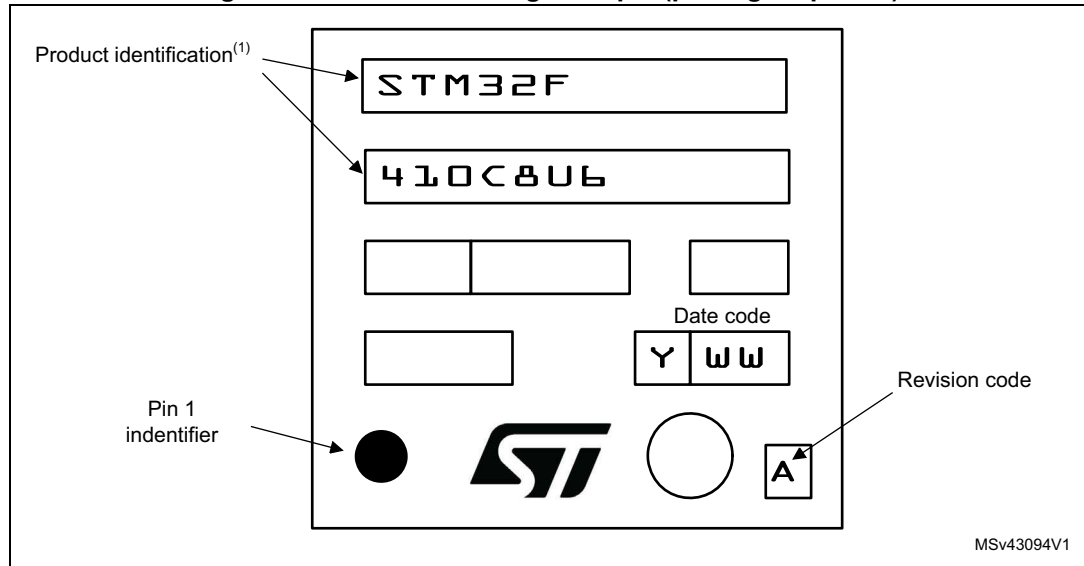

1. Parts marked as "ES", "E" or accompanied by an Engineering Sample notification letter, are not yet qualified and therefore not yet ready to be used in production and any consequences deriving from such usage will not be at ST charge. In no event, ST will be liable for any customer usage of these engineering samples in production. ST Quality has to be contacted prior to any decision to use these Engineering samples to run qualification activity.

7.4 LQFP64 package information

Figure 50. LQFP64 - 64-pin, 10 x 10 mm low-profile quad flat package outline

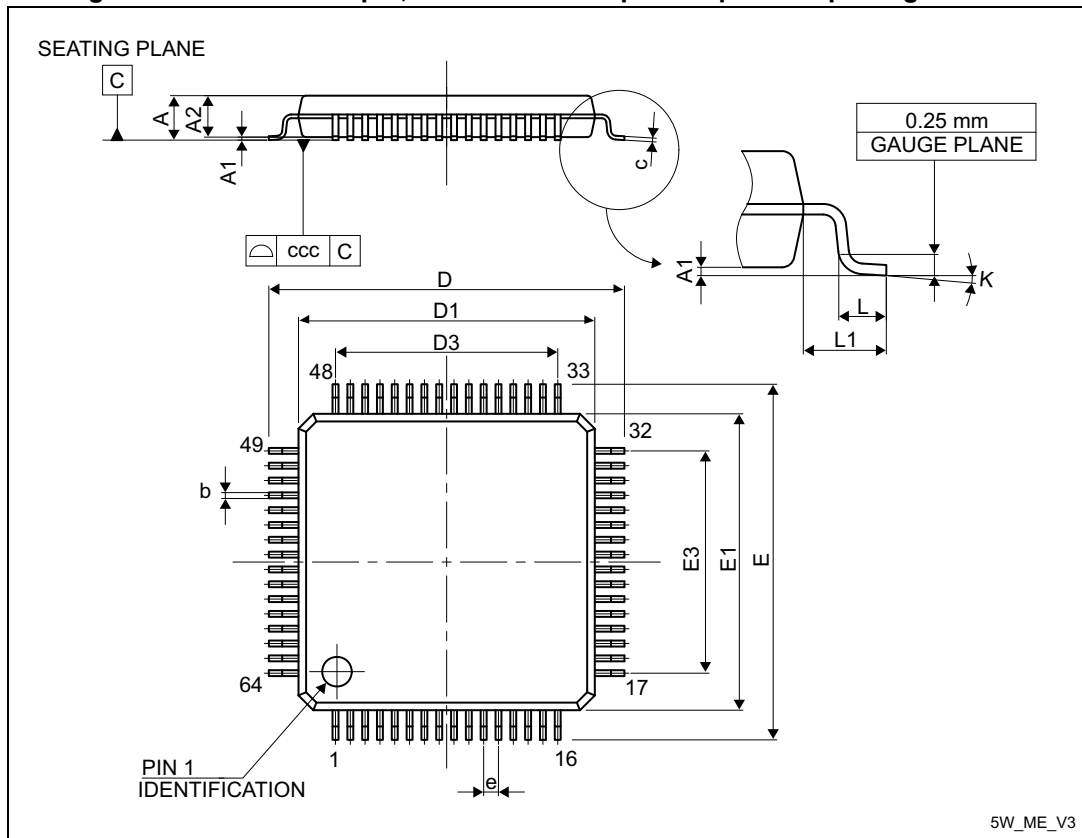

1. Drawing is not to scale.

5W_ME_V3

Table 83. LQFP64 - 64-pin, 10 x 10 mm low-profile quad flat package mechanical data

Symbol	millimeters			inches ⁽¹⁾		
	Min.	Typ.	Max.	Min.	Typ.	Max.
A	-	-	1.600	-	-	0.0630
A1	0.050	-	0.150	0.0020	-	0.0059
A2	1.350	1.400	1.450	0.0531	0.0551	0.0571
b	0.170	0.220	0.270	0.0067	0.0087	0.0106
c	0.090	-	0.200	0.0035	-	0.0079
D	-	12.000	-	-	0.4724	-
D1	-	10.000	-	-	0.3937	-
D3	-	7.500	-	-	0.2953	-
E	-	12.000	-	-	0.4724	-
E1	-	10.000	-	-	0.3937	-
E3	-	7.500	-	-	0.2953	-
e	-	0.500	-	-	0.0197	-
K	0°	3.5°	7°	0°	3.5°	7°
L	0.450	0.600	0.750	0.0177	0.0236	0.0295
L1	-	1.000	-	-	0.0394	-
ccc	-	-	0.080	-	-	0.0031

1. Values in inches are converted from mm and rounded to 4 decimal digits.

Figure 51. LQFP64 recommended footprint

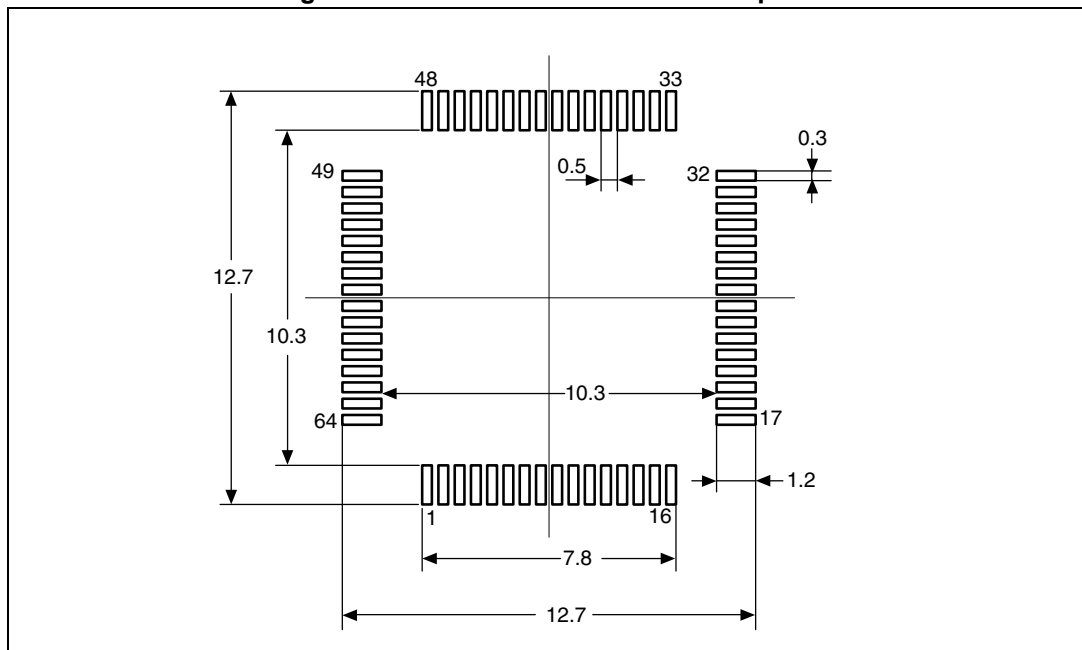

1. Dimensions are in millimeters.

LQFP64 device marking

The following figure gives an example of topside marking orientation versus pin 1 identifier location.

Other optional marking or inset/upset marks, which identify the parts throughout supply chain operations, are not indicated below.

Figure 52. LQFP64 marking example (package top view)

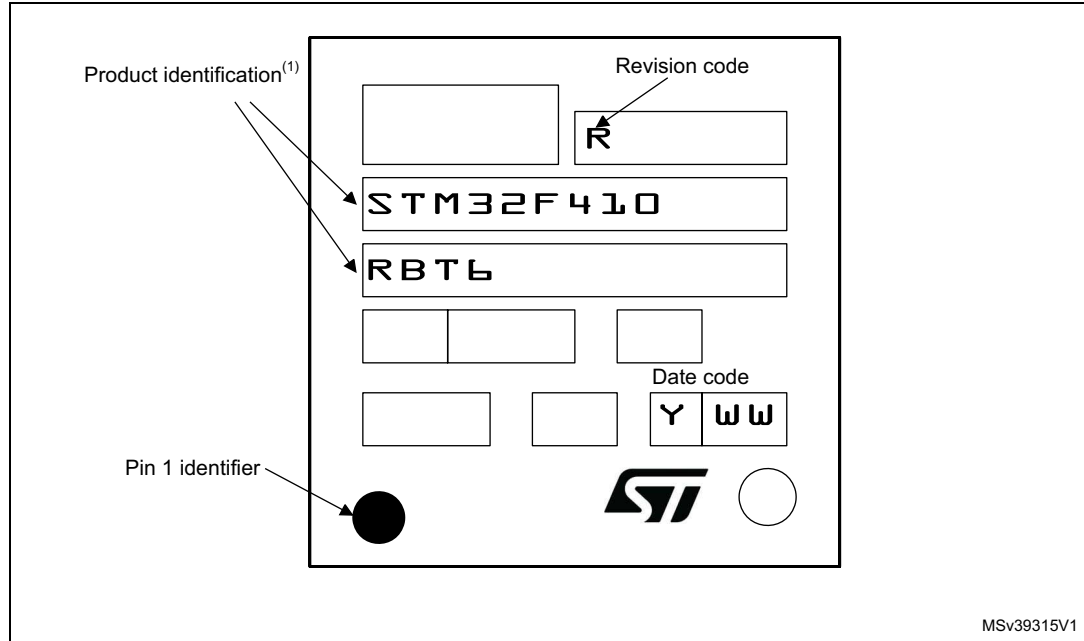

1. Parts marked as “ES”, “E” or accompanied by an Engineering Sample notification letter, are not yet qualified and therefore not yet ready to be used in production and any consequences deriving from such usage will not be at ST charge. In no event, ST will be liable for any customer usage of these engineering samples in production. ST Quality has to be contacted prior to any decision to use these Engineering samples to run qualification activity.

7.5 UFBGA64 package information

Figure 53. UFBGA64 – 64-ball, 5 x 5 mm, 0.5 mm pitch ultra profile fine pitch ball grid array package outline

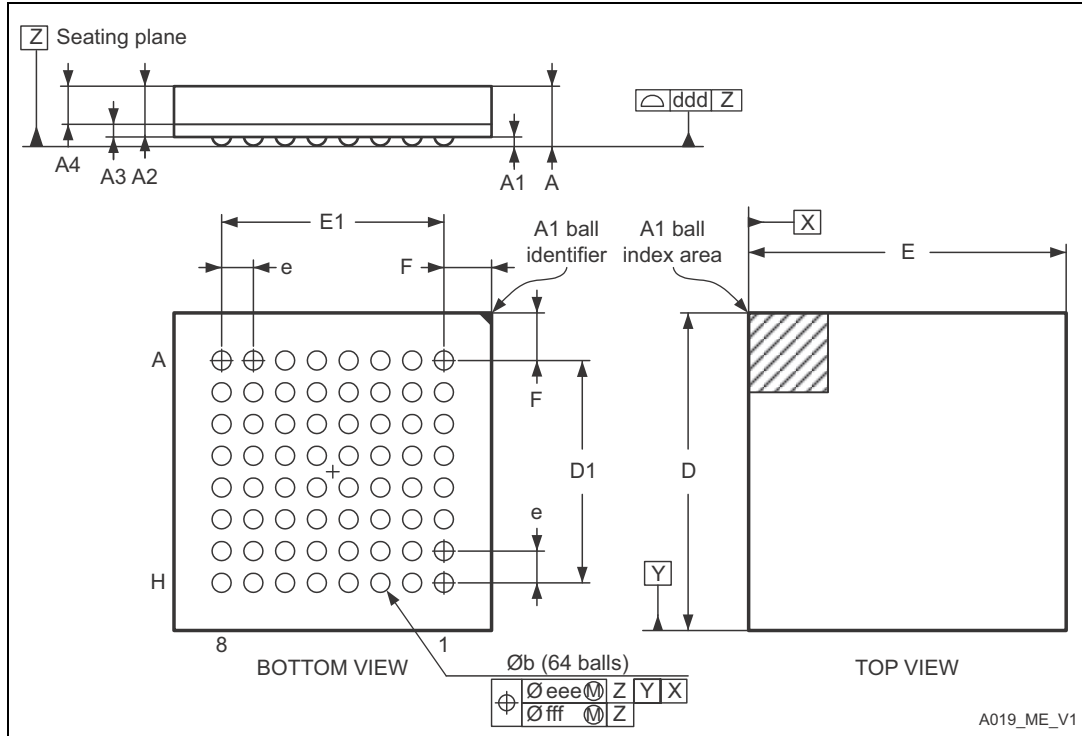

1. Drawing is not to scale.

Table 84. UFBGA64 – 64-ball, 5 x 5 mm, 0.5 mm pitch ultra profile fine pitch ball grid array package mechanical data

Symbol	millimeters			inches ⁽¹⁾		
	Min	Typ	Max	Min	Typ	Max
A	0.460	0.530	0.600	0.0181	0.0209	0.0236
A1	0.050	0.080	0.110	0.0020	0.0031	0.0043
A2	0.400	0.450	0.500	0.0157	0.0177	0.0197
A3	0.080	0.130	0.180	0.0031	0.0051	0.0071
A4	0.270	0.320	0.370	0.0106	0.0126	0.0146
b	0.170	0.280	0.330	0.0067	0.0110	0.0130
D	4.850	5.000	5.150	0.1909	0.1969	0.2028
D1	3.450	3.500	3.550	0.1358	0.1378	0.1398
E	4.850	5.000	5.150	0.1909	0.1969	0.2028
E1	3.450	3.500	3.550	0.1358	0.1378	0.1398
e	-	0.500	-	-	0.0197	-

Table 84. UFBGA64 – 64-ball, 5 x 5 mm, 0.5 mm pitch ultra profile fine pitch ball grid array package mechanical data (continued)

Symbol	millimeters			inches ⁽¹⁾		
	Min	Typ	Max	Min	Typ	Max
A	0.460	0.530	0.600	0.0181	0.0209	0.0236
F	0.700	0.750	0.800	0.0276	0.0295	0.0315
ddd	-	-	0.080	-	-	0.0031
eee	-	-	0.150	-	-	0.0059
fff	-	-	0.050	-	-	0.0020

1. Values in inches are converted from mm and rounded to 4 decimal digits.

Figure 54. UFBGA64 – 64-ball, 5 x 5 mm, 0.5 mm pitch ultra profile fine pitch ball grid array package recommended footprint

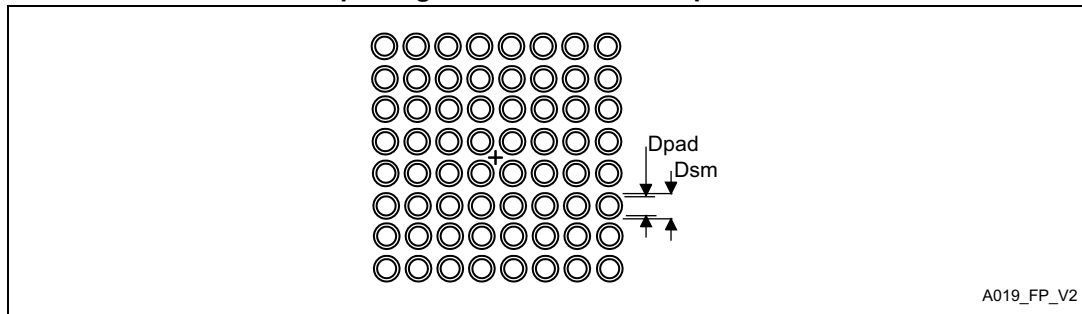

A019_FP_V2

Table 85. UFBGA64 recommended PCB design rules (0.5 mm pitch BGA)

Dimension	Recommended values
Pitch	0.5
Dpad	0.280 mm
Dsm	0.370 mm typ. (depends on the soldermask registration tolerance)
Stencil opening	0.280 mm
Stencil thickness	Between 0.100 mm and 0.125 mm
Pad trace width	0.100 mm

UFBGA64 device marking

The following figure gives an example of topside marking orientation versus ball A1 identifier location.

Other optional marking or inset/upset marks, which identify the parts throughout supply chain operations, are not indicated below.

Figure 55. UFBGA64 marking example (package top view)

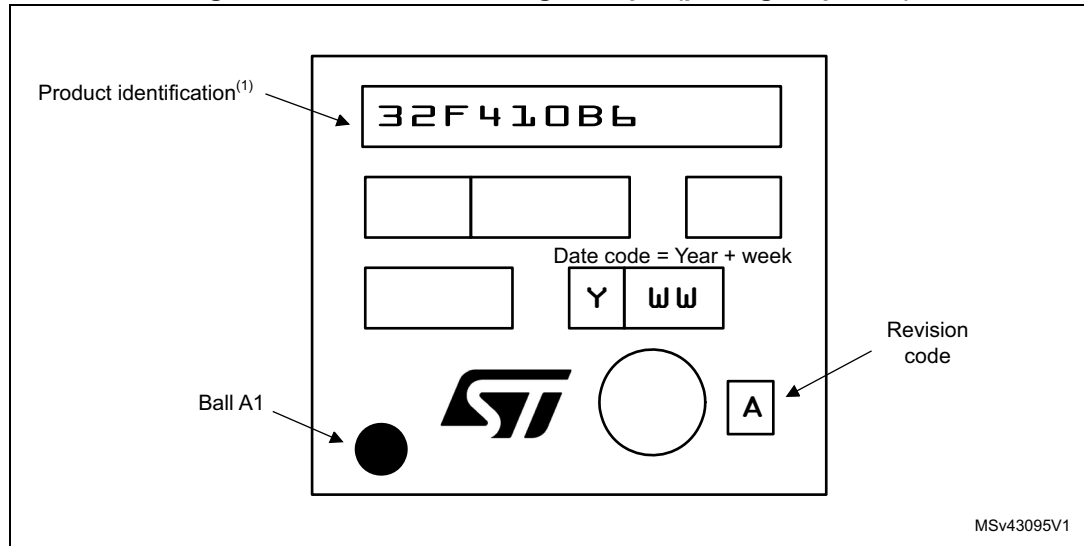

1. Parts marked as "ES", "E" or accompanied by an Engineering Sample notification letter, are not yet qualified and therefore not yet ready to be used in production and any consequences deriving from such usage will not be at ST charge. In no event, ST will be liable for any customer usage of these engineering samples in production. ST Quality has to be contacted prior to any decision to use these Engineering samples to run qualification activity.

7.6 Thermal characteristics

The maximum chip junction temperature (T_{Jmax}) must never exceed the values given in [Table 15: General operating conditions on page 53](#).

The maximum chip-junction temperature, $T_J max.$, in degrees Celsius, may be calculated using the following equation:

$$T_J max = T_A max + (PD max \times \Theta_{JA})$$

Where:

- $T_A max$ is the maximum ambient temperature in °C,
- Θ_{JA} is the package junction-to-ambient thermal resistance, in °C/W,
- PD max is the sum of $P_{INT max}$ and $P_{I/O max}$ ($PD max = P_{INT max} + P_{I/O max}$),
- $P_{INT max}$ is the product of I_{DD} and V_{DD} , expressed in Watts. This is the maximum chip internal power.

$P_{I/O max}$ represents the maximum power dissipation on output pins where:

$$P_{I/O max} = \Sigma (V_{OL} \times I_{OL}) + \Sigma (V_{DD} - V_{OH}) \times I_{OH},$$

taking into account the actual V_{OL} / I_{OL} and V_{OH} / I_{OH} of the I/Os at low and high level in the application.

Table 86. Package thermal characteristics

Symbol	Parameter	Value	Unit
Θ_{JA}	Thermal resistance junction-ambient LQFP48	55	°C/W
	Thermal resistance junction-ambient LQFP64	46	
	Thermal resistance junction-ambient UFQFPN48	33	
	Thermal resistance junction-ambient WLCSP36	61	
	Thermal resistance junction-ambient UFBGA64	79	

7.6.1 Reference document

JESD51-2 Integrated Circuits Thermal Test Method Environment Conditions - Natural Convection (Still Air). Available from www.jedec.org.

8 Part numbering

Table 87. Ordering information scheme

Example:	STM32	F	410	C	B	Y	6	TR
Device family								
STM32 = Arm [®] -based 32-bit microcontroller								
Product type								
F = General-purpose								
Device subfamily								
410 = 410 line								
Pin count								
T = 36 pins								
C = 48 pins								
R = 64 pins								
Flash memory size								
8 = 64 Kbytes of Flash memory								
B = 128 Kbytes of Flash memory								
Package								
I = UFBGA								
T = LQFP								
U = UFQFPN								
Y = WLCSP								
Temperature range								
6 = Industrial temperature range, - 40 to 85 °C								
7 = Industrial temperature range, - 40 to 105 °C								
3 = Industrial temperature range, - 40 to 125 °C								
Packing								
TR = tape and reel								
No character = tray or tube								

Appendix A Recommendations when using the internal reset OFF

When the internal reset is OFF, the following integrated features are no longer supported:

- The integrated power-on-reset (POR)/power-down reset (PDR) circuitry is disabled.
- The brownout reset (BRO) circuitry must be disabled. By default BOR is OFF.
- The embedded programmable voltage detector (PVD) is disabled.
- VBAT functionality is no more available and VBAT pin should be connected to VDD.

A.1 Operating conditions

Table 88. Limitations depending on the operating power supply range

Operating power supply range	ADC operation	Maximum Flash memory access frequency with no wait state ($f_{Flashmax}$)	Maximum Flash memory access frequency with no wait states ^{(1) (2)}	I/O operation	Possible Flash memory operations
$V_{DD} = 1.7$ to 2.1 V ⁽³⁾	Conversion time up to 1.2 Msps	20 MHz ⁽⁴⁾	100 MHz with 6 wait states	No I/O compensation	8-bit erase and program operations only

1. Applicable only when the code is executed from Flash memory. When the code is executed from RAM, no wait state is required.
2. Thanks to the ART Accelerator and the 128-bit Flash memory, the number of wait states given here does not impact the execution speed from Flash memory since the ART Accelerator allows to achieve a performance equivalent to 0 wait state program execution.
3. V_{DD}/V_{DDA} minimum value of 1.7 V, with the use of an external power supply supervisor (refer to [Section 3.15.1: Internal reset ON](#)).
4. Prefetch is not available. Refer to AN3430 application note for details on how to adjust performance and power.

Appendix B Application block diagrams

B.1 Sensor Hub application example

Figure 56. Sensor hub application example 1

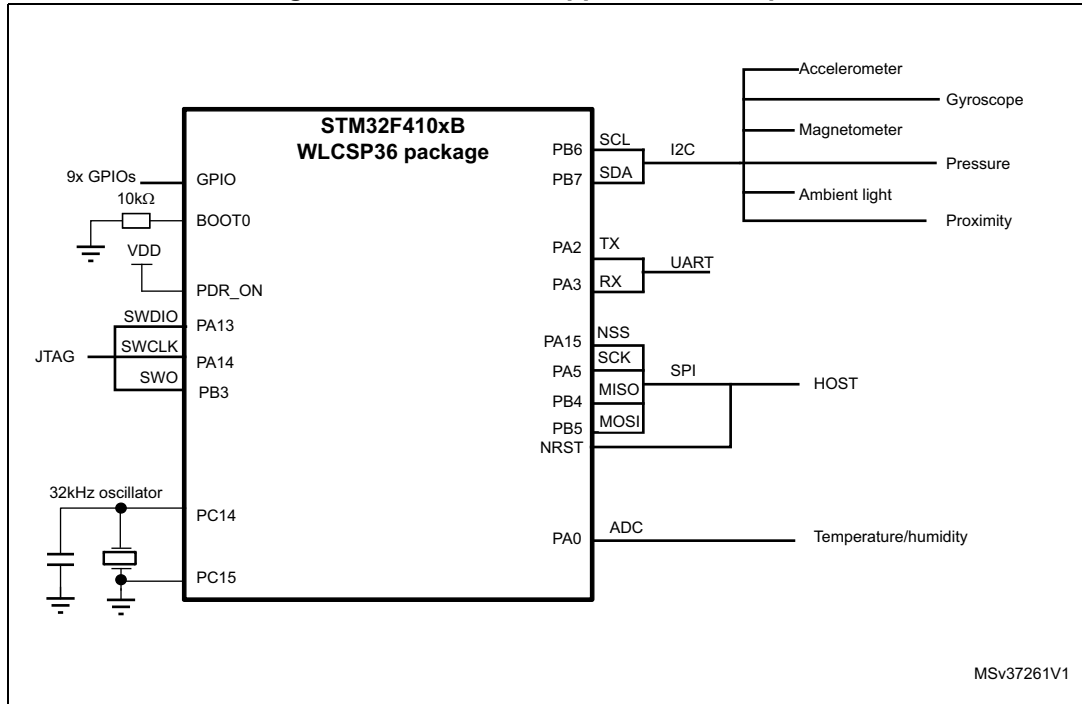
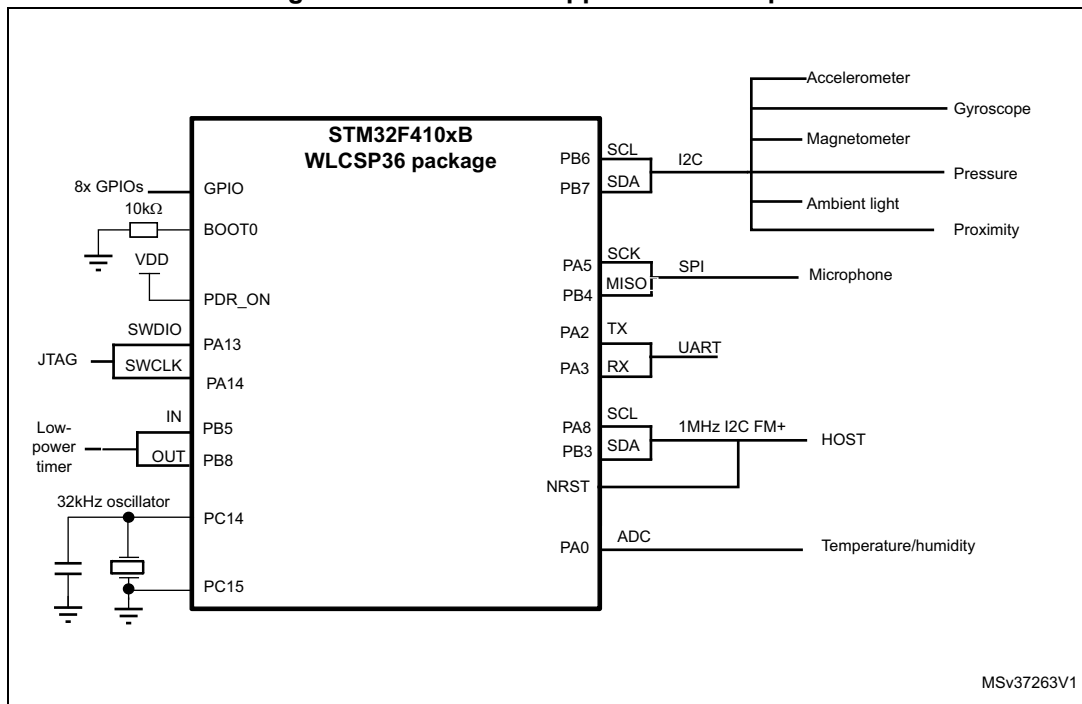

Figure 57. Sensor hub application example 2



B.2 Batch Acquisition Mode (BAM) example

Data is transferred through the DMA from interfaces into the internal SRAM while the rest of the MCU is set in low power mode.

- Code execution from RAM before switching off the Flash.
- Flash is set in power down and flash interface (ART accelerator™) clock is stopped.
- The clocks are enabled only for the required interfaces.
- MCU core is set in sleep mode (core clock stopped waiting for interrupt).
- Only the needed DMA channels are enabled and running.

Figure 58. Batch Acquisition Mode (BAM) example

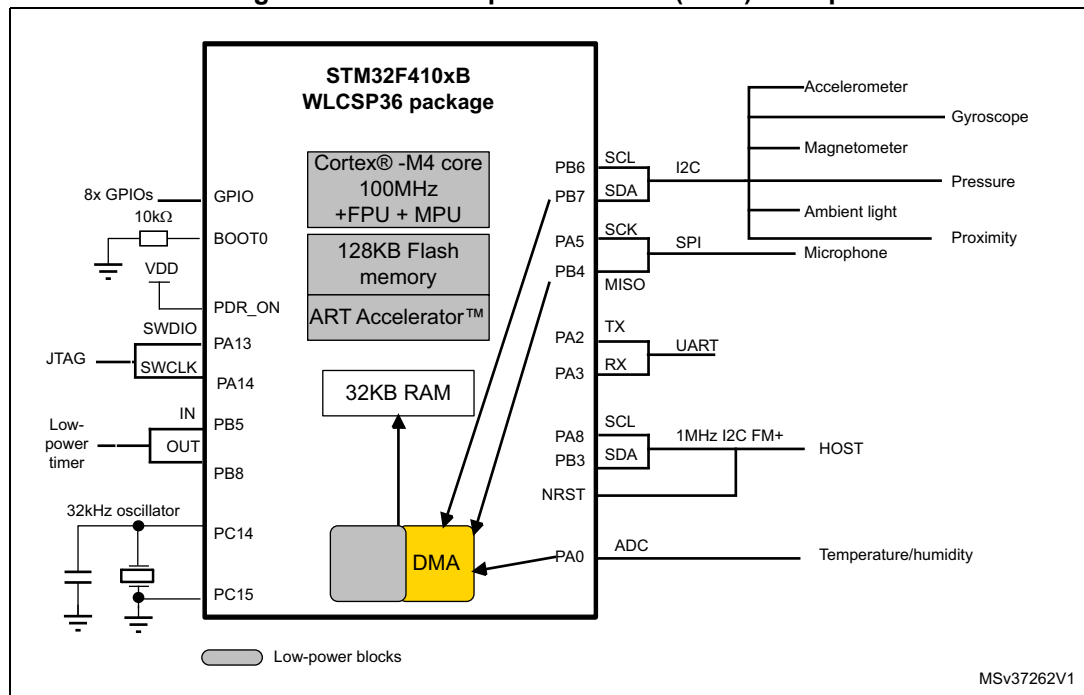

Revision history

Table 89. Document revision history

Date	Revision	Changes
28-Sep-2015	1	Initial release.
07-Dec-2015	2	Junction temperature range changed to –40 to + 110 °C for WLCSP49 package. Updated Figure 7: UFQFPN48 pinout .
10-Aug-2016	3	Updated: <ul style="list-style-type: none"> – Table 2: STM32F410x8/B features and peripheral counts – Table 9: STM32F410x8/B pin definitions – Table 14: Thermal characteristics – Table 15: General operating conditions – Table 20: Embedded reset and power control block characteristics – Tables from Table 21: Typical and maximum current consumption, code with data processing (ART accelerator disabled) running from SRAM - $V_{DD} = 1.7 V$ to Table 34: Typical and maximum current consumptions in V_{BAT} mode (LSE and RTC ON, LSE low-drive mode) – Table 42: HSI oscillator characteristics – Table 43: LSI oscillator characteristics – Table 49: Flash memory endurance and data retention – Table 52: ESD absolute maximum ratings – Table 55: I/O static characteristics – Table 66: ADC characteristics – Table 75: Embedded internal reference voltage – Table 77: DAC characteristics – Table 87: Ordering information scheme – Figure 16: Typical V_{BAT} current consumption (LSE and RTC ON/LSE oscillator in “low power” mode selection) – Section 7: Package information Added: <ul style="list-style-type: none"> – Figure 5: LQFP48 pinout – Figure 8: UFBGA64 pinout – Figure 49: LQFP48 marking example (package top view) – Figure 55: UFBGA64 marking example (package top view)

Table 89. Document revision history (continued)

Date	Revision	Changes
06-Mar-2017	4	Updated: <ul style="list-style-type: none"> – Features – Section 3.20: Timers and watchdogs – Table 9: STM32F410x8/B pin definitions – Table 21: Typical and maximum current consumption, code with data processing (ART accelerator disabled) running from SRAM - V_{DD} = 1.7 V – Table 22: Typical and maximum current consumption, code with data processing (ART accelerator disabled) running from SRAM - V_{DD} = 3.6 V – Table 24: Typical and maximum current consumption in run mode, code with data processing (ART accelerator enabled except prefetch) running from Flash memory - V_{DD} = 3.6 V – Table 28: Typical and maximum current consumption in Sleep mode - V_{DD} = 3.6 V – Table 31: Typical and maximum current consumption in Stop mode - V_{DD}=3.6 V – Table 34: Typical and maximum current consumptions in V_{BAT} mode (LSE and RTC ON, LSE low- drive mode)
04-Apr-2017	5	The maximum current consumption at 30 °C has been redefined to be in line with the actual silicon performance. For a typical customer application the impact on the average current consumption will be insignificant. <p>Updated:</p> <ul style="list-style-type: none"> – Table 21: Typical and maximum current consumption, code with data processing (ART accelerator disabled) running from SRAM - V_{DD} = 1.7 V – Table 22: Typical and maximum current consumption, code with data processing (ART accelerator disabled) running from SRAM - V_{DD} = 3.6 V – Table 23: Typical and maximum current consumption in run mode, code with data processing (ART accelerator enabled except prefetch) running from Flash memory- V_{DD} = 1.7 V – Table 24: Typical and maximum current consumption in run mode, code with data processing (ART accelerator enabled except prefetch) running from Flash memory - V_{DD} = 3.6 V – Table 25: Typical and maximum current consumption in run mode, code with data processing (ART accelerator disabled) running from Flash memory - V_{DD} = 3.6 V – Table 26: Typical and maximum current consumption in run mode, code with data processing (ART accelerator disabled) running from Flash memory - V_{DD} = 1.7 V – Table 27: Typical and maximum current consumption in run mode, code with data processing (ART accelerator enabled with prefetch) running from Flash memory - V_{DD} = 3.6 V – Table 37: Low-power mode wakeup timings – Figure 30: I²C bus AC waveforms and measurement circuit – Figure 31: FMP²C timing diagram and measurement circuit

Table 89. Document revision history (continued)

Date	Revision	Changes
15-Dec-2017	6	Updated: <ul style="list-style-type: none"> – <i>Table 21: Typical and maximum current consumption, code with data processing (ART accelerator disabled) running from SRAM - $V_{DD} = 1.7\text{ V}$</i> – <i>Table 22: Typical and maximum current consumption, code with data processing (ART accelerator disabled) running from SRAM - $V_{DD} = 3.6\text{ V}$</i> – <i>Table 24: Typical and maximum current consumption in run mode, code with data processing (ART accelerator enabled except prefetch) running from Flash memory - $V_{DD} = 3.6\text{ V}$</i> – <i>Table 28: Typical and maximum current consumption in Sleep mode - $V_{DD} = 3.6\text{ V}$</i> – <i>Table 31: Typical and maximum current consumption in Stop mode - $V_{DD} = 3.6\text{ V}$</i> – <i>Table 33: Typical and maximum current consumption in Standby mode - $V_{DD} = 3.6\text{ V}$</i> – <i>Table 87: Ordering information scheme</i>

IMPORTANT NOTICE – PLEASE READ CAREFULLY

STMicroelectronics NV and its subsidiaries ("ST") reserve the right to make changes, corrections, enhancements, modifications, and improvements to ST products and/or to this document at any time without notice. Purchasers should obtain the latest relevant information on ST products before placing orders. ST products are sold pursuant to ST's terms and conditions of sale in place at the time of order acknowledgement.

Purchasers are solely responsible for the choice, selection, and use of ST products and ST assumes no liability for application assistance or the design of Purchasers' products.

No license, express or implied, to any intellectual property right is granted by ST herein.

Resale of ST products with provisions different from the information set forth herein shall void any warranty granted by ST for such product.

ST and the ST logo are trademarks of ST. All other product or service names are the property of their respective owners.

Information in this document supersedes and replaces information previously supplied in any prior versions of this document.

© 2017 STMicroelectronics – All rights reserved

