



HESTORE.HU

elektronikai alkatrész áruház

EN: This Datasheet is presented by the manufacturer.

Please visit our website for pricing and availability at www.hestore.hu.

Version:
July 4, 2017



(PT-IC-AC) Visible Light Sensor RoHS Compliant

Token Electronics Industry Co., Ltd.

Taiwan: No.137, Sec. 1, Zhongxing Rd., Wugu District,
New Taipei City, Taiwan, R.O.C. 24872
Tel: +886 2981 0109 Fax: +886 2988 7487

China: 12F, Zhong Xing Industry Bld., Chuang Ye Road,
Nan Shan District, Shen Zhen City,
Guang Dong, China 518054
Tel: +86 755 26055363; Fax: +86 755 26055365

[Web: www.token.com.tw](http://www.token.com.tw)

[Email: rfq@token.com.tw](mailto:rfq@token.com.tw)



▶ Product Introduction

Token providing optimized light sensing solutions to enhance system efficiency and ease-of-design.

Features :

- Simulate the human eye, peak wavelength 550nm.
- Built-in infrared filter, can be anti-infrared interference.
- Good batch consistency, completely solve the infrared light start too early.
- Fast response, stable performance, aging at +85°C/ 65% humidity for 1000 Hr.
- The starting point does not drift. Nice appearance.

Applications :

- Replace the traditional CDS photoresistor.
- Cadmium and lead free with RoHS compliant.
- Dedicated to infrared monitoring products.
- When control the infrared light, it is no need to add extra casing and filter on low illumination.

Customization :

- For the convenience of installation in all kinds of products in any position, different sizes are available upon request.
- Token offers various option of the bright current/dark current (bright resistance/dark resistance) to costume the most products.

(PT-IC-AC) visible light sensor is a silicon NPN epitaxial planar phototransistor in a T-1 package. It is sensitive to visible light much like the human eye and has peak sensitivity at 520nm ~ 580nm.

The spectral response of the integrated light sensor with a very low dark current that are optimized for sensing low level light signals. So it ignores light such as infrared which emits energy but does not aid vision. This eliminates the need for an Infrared filter required with competitor light sensors.

The (PT-IC-AC) Plate Edge IR visible light detector using high quality chip packaging and processing super-plated infrared filter membrane on chip surface, so this sensor can fully filter infrared interference. It is no need to add the casing and extra filter and effective filtering out the effect of light reflection due to infrared emission on security products.

By selecting the accuracy of chips, under strict management of production process, (PT-IC-AC) visible light sensors finished batch consistency uniform. The consistency is 3 to 5 times higher on comparison of similar photosensitive devices. The precision can be controlled as narrow as 10%. Fully meet the customer requirements for starting the LUX value. Token taking the advantage of temperature compensation internal process on the chip, (PT-IC-AC) features one times higher temperature resistance than other similar products while working on high temperature environment. Please contact our sales or link to Token official website "[Visible Light Sensors](http://www.token.com.tw)" for more information.



► **Dimensions**

Dimensions & Configurations (Unit: mm) (PT-IC-AC-PE-550) Plate Edge

Part NO.	A (mm)	B (mm)	C (mm)	D (mm)	E (mm)	F (mm)	G (mm)	H (mm)	I (mm)
PT-IC-AC-3-PE-550	4.05 ± 0.20	3.00 ± 0.20	1.50 Max.	1.50 ± 0.5	2.54 ± 0.20	3.85 ± 0.20	0.75 ± 0.20	25.4 Min.	0.50 ± 0.20
PT-IC-AC-5-PE-550	5.80 ± 0.20	5.00 ± 0.20	1.50 Max.	1.50 ± 0.50	2.54 ± 0.20	5.30 ± 0.20	1.00 ± 0.20	25.4 Min.	0.50 ± 0.50

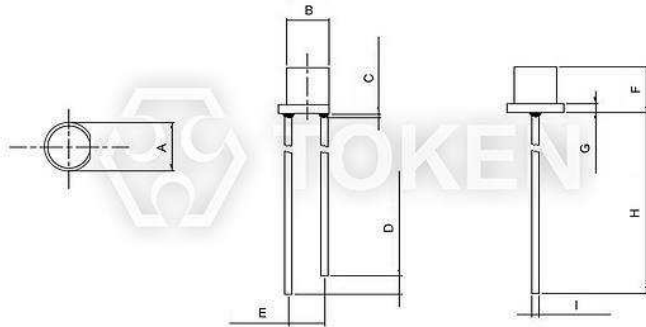

Visible Light Sensor RoHS Compliant (PT-IC-AC-PE-550) Dimensions



Visible Light Sensor RoHS Compliant (PT-IC-AC-PE-550)

Remark:

- The epoxy resin highest: 1.5mm max.
- Product images, plastic color of appearance, and all other information is for reference only, goods in-kind prevail.
- Short Lead—Collector Long Lead—Emitter.

Dimensions & Configurations (Unit: mm) (PT-IC-AC-5-BN-520) Bullet None

Part NO.	A (mm)	B (mm)	C (mm)	D (mm)	E (mm)	F (mm)	G (mm)	H (mm)
PT-IC-AC-5-BN-520	5.00 ± 0.20	5.00 ± 0.20	1.50 Max.	2.00 ± 0.5	2.54 ± 0.20	7.00 ± 0.20	14.00 Min.	0.50 ± 0.20

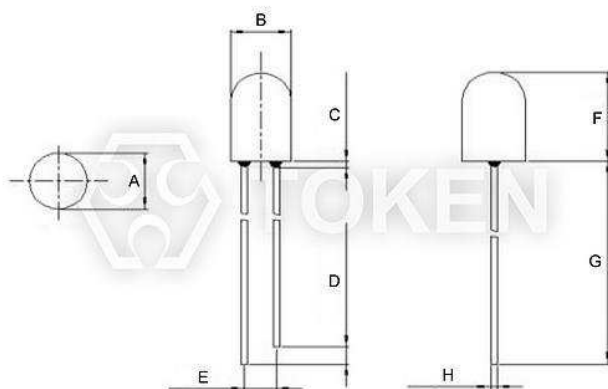

Visible Light Sensor RoHS Compliant (PT-IC-AC-5-BN-520) Dimensions



Visible Light Sensor RoHS Compliant (PT-IC-AC-5-PN-580)

Remark:

- The epoxy resin highest: 1.5mm max.
- Product images, plastic color of appearance, and all other information is for reference only, goods in-kind prevail.
- Short Lead—Collector Long Lead—Emitter.

Dimensions & Configurations (Unit: mm) (PT-IC-AC-5-PN-580) Plate None

Part NO.	A (mm)	B (mm)	C (mm)	D (mm)	E (mm)	F (mm)
PT-IC-AC-5-PN-580	5.00 ± 0.20	5.00 ± 0.20	5.30 ± 0.20	14.0 Min.	2.00 ± 0.50	2.54 ± 0.20

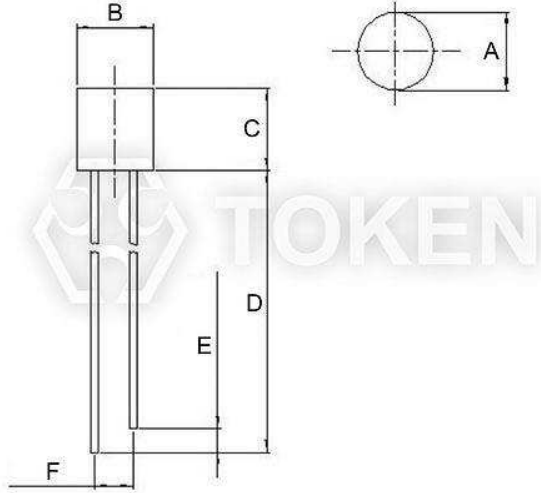

Visible Light Sensor RoHS Compliant (PT-IC-AC-5-PN-580) Dimensions



**Visible Light Sensor RoHS Compliant
(PT-IC-AC-5-PN-580)**

Remark:

- The epoxy resin highest: 1.5mm max.
- Product images, plastic color of appearance, and all other information is for reference only, goods in-kind prevail.
- Short Lead—Collector Long Lead—Emitter.

► PE Electro-Optical

Electro-Optical Characteristics (Ta=25 ° C) (PT-IC-AC-3-PE-550) Plate Edge

Parameter	Symbol	Condition	Min.	Typ.	Max.	Unit
Peak Wavelength	λ_p	\	-	550	-	nm
Spectral Response Range	λ	\	400	-	-	nm
Operating Voltage	V_{cc}	\	-	5	-	V
Photo Current	$I_{L(1)}$	$V_{cc}=5V$ $E_v=10Lux$	7	13	18	μA
	$I_{L(2)}$	$V_{cc}=5V$ $E_v=30Lux$	21	39	54	μA
	$I_{L(3)}$	$V_{cc}=5V$ $E_v=100Lux$	70	130	180	μA
Collector Dark Current	I_d	$V_{cc}=5V/85^\circ C$ $E_v=0Lux$	-	-	0.8	μA
Rise Time	t_r	$V_{cc}=5V$ $E_v=30Lux$	4.5			ms
Fall Time	t_f	$RL=1000\Omega$	4.5			

Electro-Optical Characteristics (Ta=25 ° C) (PT-IC-AC-5-PE-550) Plate Edge

Parameter	Symbol	Condition	Min.	Typ.	Max.	Unit
Peak Wavelength	λ_p	\	-	550	-	nm
Spectral Response Range	λ	\	400	-	-	nm
Operating Voltage	V_{cc}	\	-	5	-	V
Photo Current	$I_{L(1)}$	$V_{cc}=5V$ $E_v=10Lux$	7	13	18	μA
	$I_{L(2)}$	$V_{cc}=5V$ $E_v=30Lux$	20	39	54	μA
	$I_{L(3)}$	$V_{cc}=5V$ $E_v=100Lux$	70	130	180	μA
Collector Dark Current	I_d	$V_{cc}=5V/85^\circ C$ $E_v=0Lux$	-	-	0.8	μA
Rise Time	t_r	$V_{cc}=5V$ $E_v=30Lux$	4.5			ms
Fall Time	t_f	$RL=1000\Omega$	4.5			

Absolute maximum ratings (Ta=25 ° C) (PT-IC-AC-3-PE-550) & (PT-IC-AC-5-PE-550) Plate Edge

Parameter	Symbol	Value		Unit
		Min.	Max.	
Operating Voltage	V_{cc}			V
		1	10	V
Power Dissipation	P_c	70		m^W
Operating Temperature Range	T_{opr}	-25 ~ +85		$^\circ C$
Storage Temperature	T_{stg}	-40 ~ +100		$^\circ C$



▶ **BN Electro-Optical**

Electro-Optical Characteristics (Ta=25 ° C) (PT-IC-AC-5-BN-520) Bullet None

Parameter	Symbol	Condition	Min.	Typ.	Max.	Unit
Peak Wavelength	λ_p	\	-	520	-	nm
Spectral Response Bandwidth	λ	\	400	-	700	nm
Operating Voltage	V_{cc}	\	-	5	-	V
Photo Current	$I_{L(1)}$	$V_{cc}=5V$ $E_v=10L_{ux}$	4	8	12	μA
	$I_{L(2)}$	$V_{cc}=5V$ $E_v=30L_{ux}$	12	24	36	μA
	$I_{L(3)}$	$V_{cc}=5V$ $E_v=100L_{ux}$	40	80	120	μA
Collector Dark Current	I_d	$V_{cc}=5V/85^\circ C$ $E_v=0L_{ux}$	-	-	0.8	μA
IR Receiving Current	$I_{L(4)}$	$V_{cc}=5V/850nm$ IR LED $E_e=1m^W/cm^2$	-	-	0.05	μA
Rise Time	t_r	$V_{cc}=5V$	4.5			ms
Fall Time	t_f	$RL=1000\Omega$	4.5			

Absolute maximum ratings (Ta=25 ° C) (PT-IC-AC-5-BN-520) Bullet None

Parameter	Symbol	Value	Unit
Collector-Emitter Breakdown Voltage	V_{CEO}	60	V
Emitter-Base Breakdown Voltage	V_{ECO}	7	V
Power Dissipation	P_C	50	m^W
Operating Temperature Range	T_{opr}	-25 ~ +85	$^\circ C$
Storage Temperature	T_{stg}	-40 ~ +100	$^\circ C$



▶ PN Electro-Optical

Electro-Optical Characteristics (Ta=25 ° C) (PT-IC-AC-5-PN-580) Plate None

Parameter	Symbol	Condition	Min.	Typ.	Max.	Unit
Peak Wavelength	λ_p	\	-	580	-	nm
Spectral Response Bandwidth	λ	\	400	-	700	nm
Operating Voltage	V_{cc}	\	-	5	-	V
Photo Current	$I_{L(1)}$	$V_{cc}=5V$ $E_v=10L_{ux}$	1.5	3.5	5.5	μA
	$I_{L(2)}$	$V_{cc}=5V$ $E_v=30L_{ux}$	4.5	10.5	16.5	μA
	$I_{L(3)}$	$V_{cc}=5V$ $E_v=100L_{ux}$	15	35	55	μA
Collector Dark Current	I_D	$V_{cc}=5V/85^\circ C$ $E_v=0L_{ux}$	-	-	0.8	μA
IR Receiving Current	$I_{L(4)}$	$V_{cc}=5V/850nm$ ir LED $E_c=1m^w/cm^2$	-	-	0.05	μA
Rise Time	t_r	$V_{cc}=5V$	4.5			ms
Fall Time	t_f	$RL=1000\Omega$	4.5			

Absolute maximum ratings (Ta=25 ° C) (PT-IC-AC-5-PN-580) Plate None

Parameter	Symbol	Value		Unit
		Min.	Max.	
Operating Voltage	V_{cc}			V
		1	10	V
Operating Temperature Range	T_{opr}	-25 ~ +85		$^\circ C$
Storage Temperature	T_{stg}	-40 ~ +100		$^\circ C$
Soldering Temperature	T_{sol}	260		$^\circ C$



▶ 3-PE Curve

Relative Spectral Sensitivity vs. Wavelength (PT-IC-AC-3-PE-550)

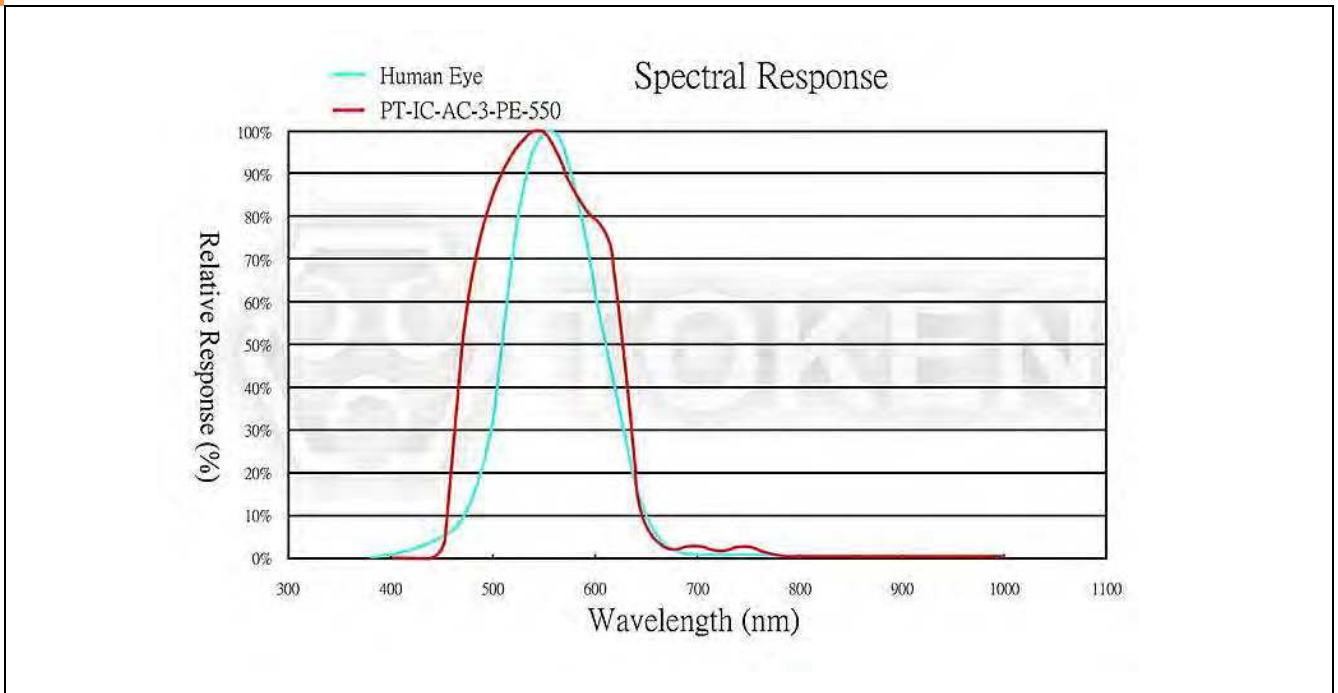
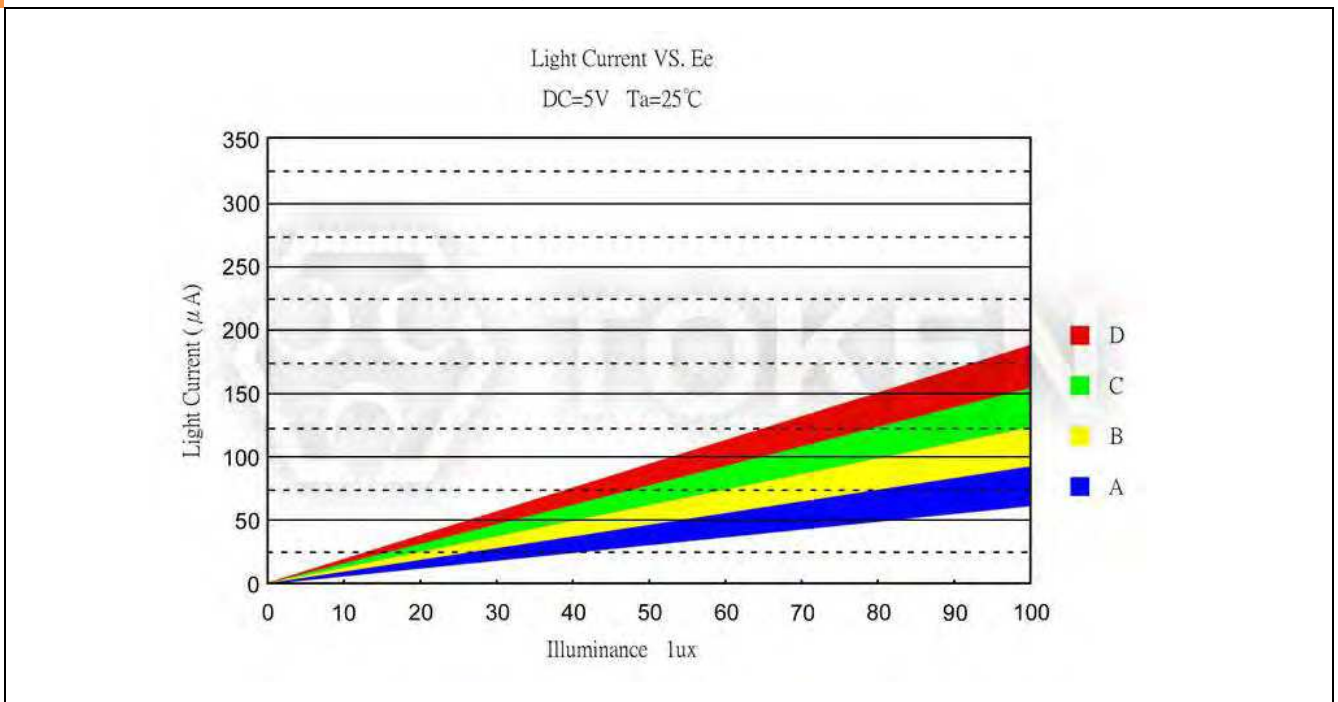
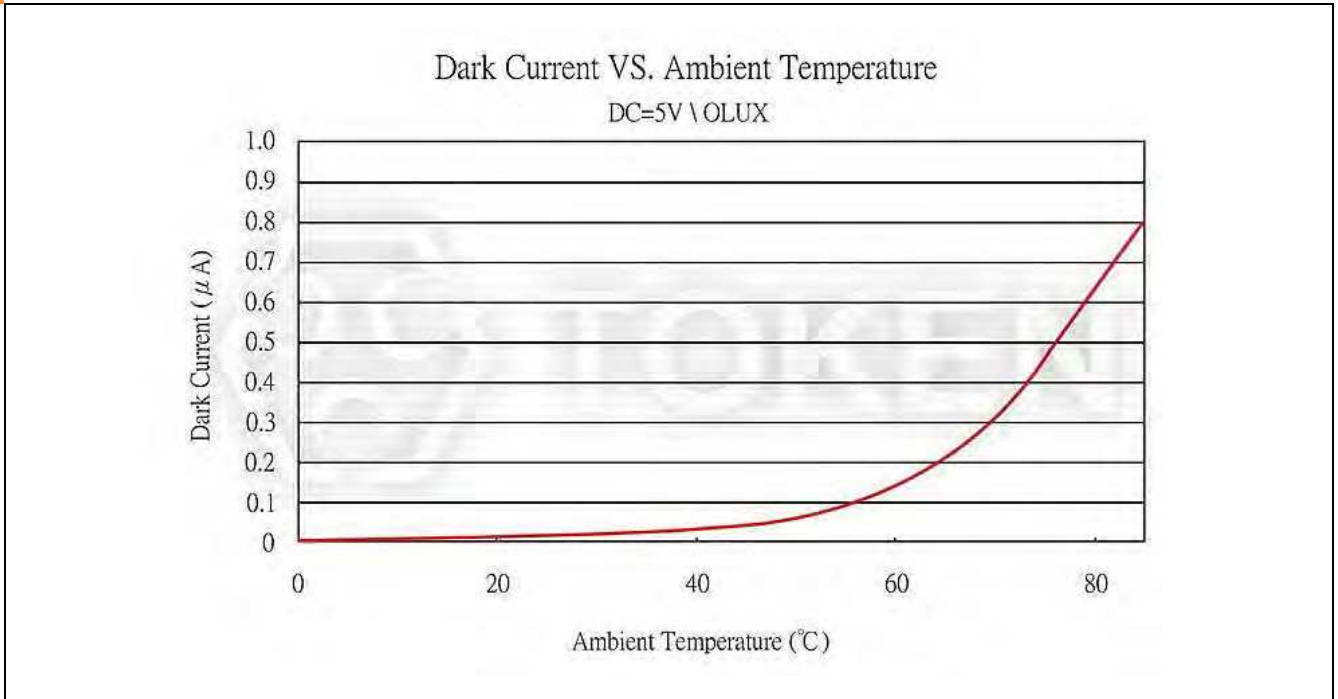

Photo Current vs. Illuminance (PT-IC-AC-3-PE-550)



Dark Current vs. Ambient Temperature (PT-IC-AC-3-PE-550)



► 5-PE Curve

Relative Spectral Sensitivity vs. Wavelength (PT-IC-AC-5-PE-550)

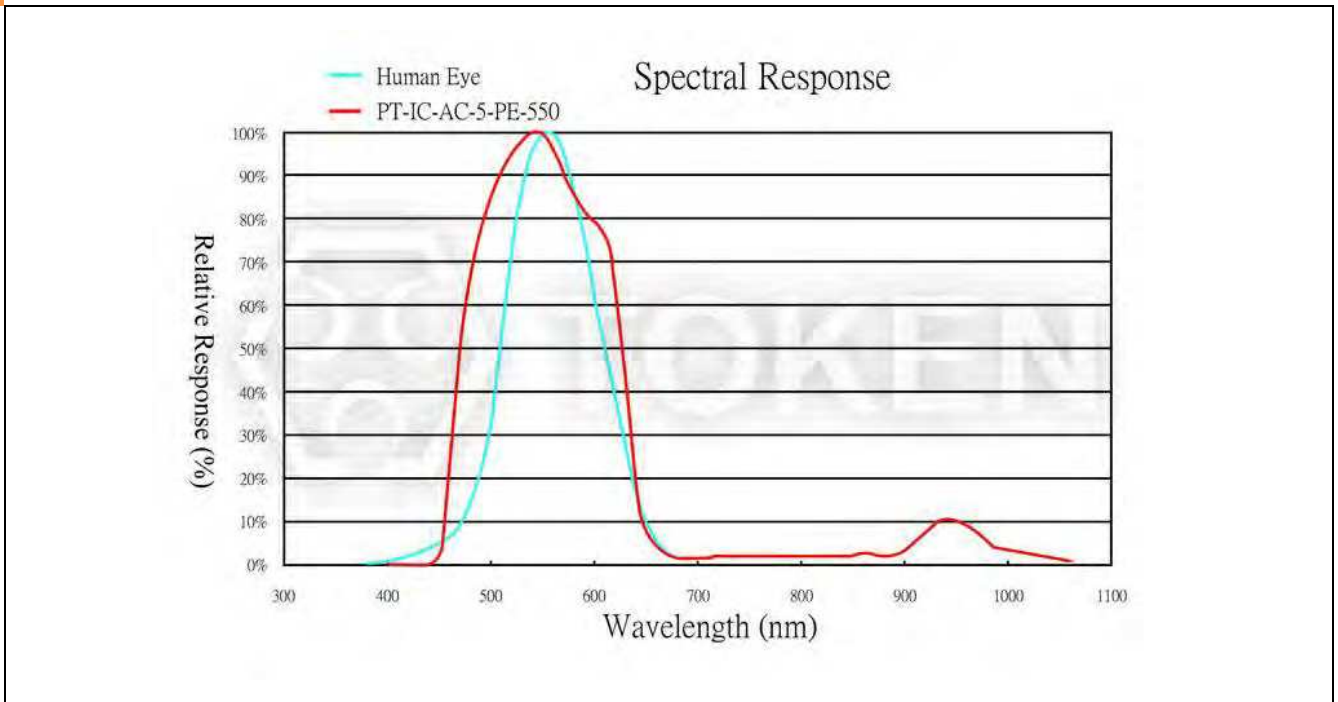
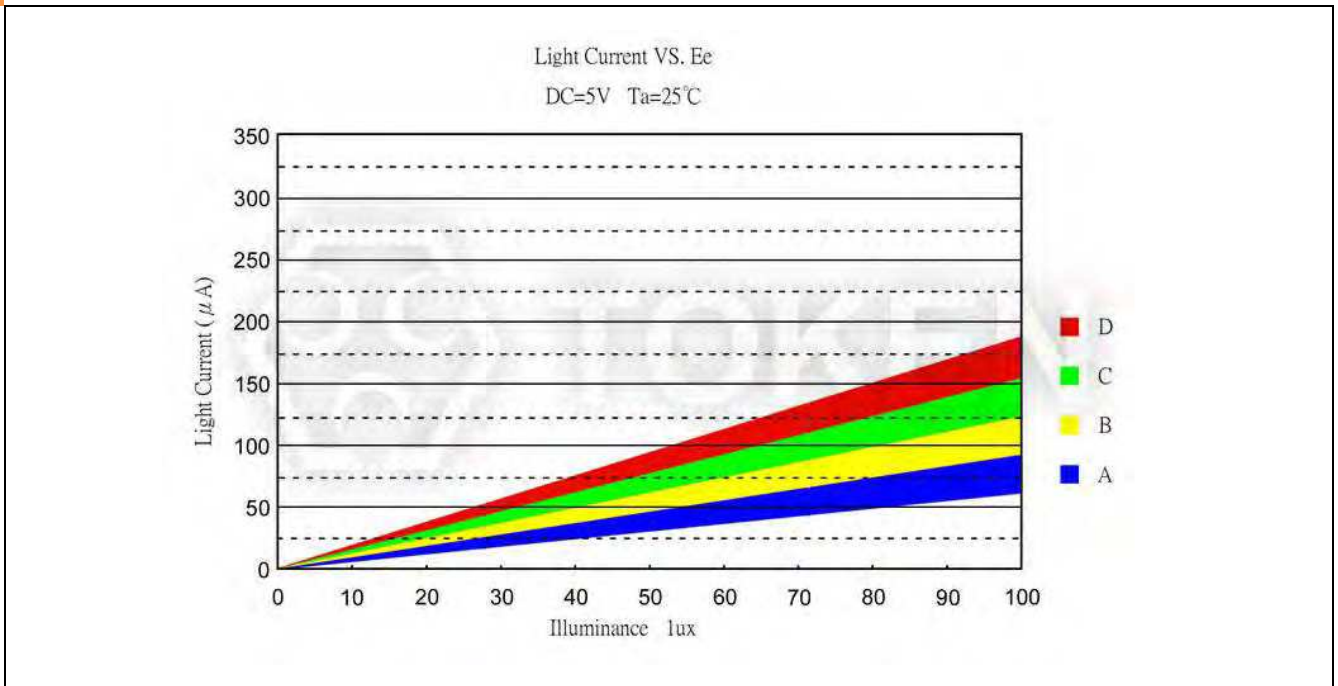
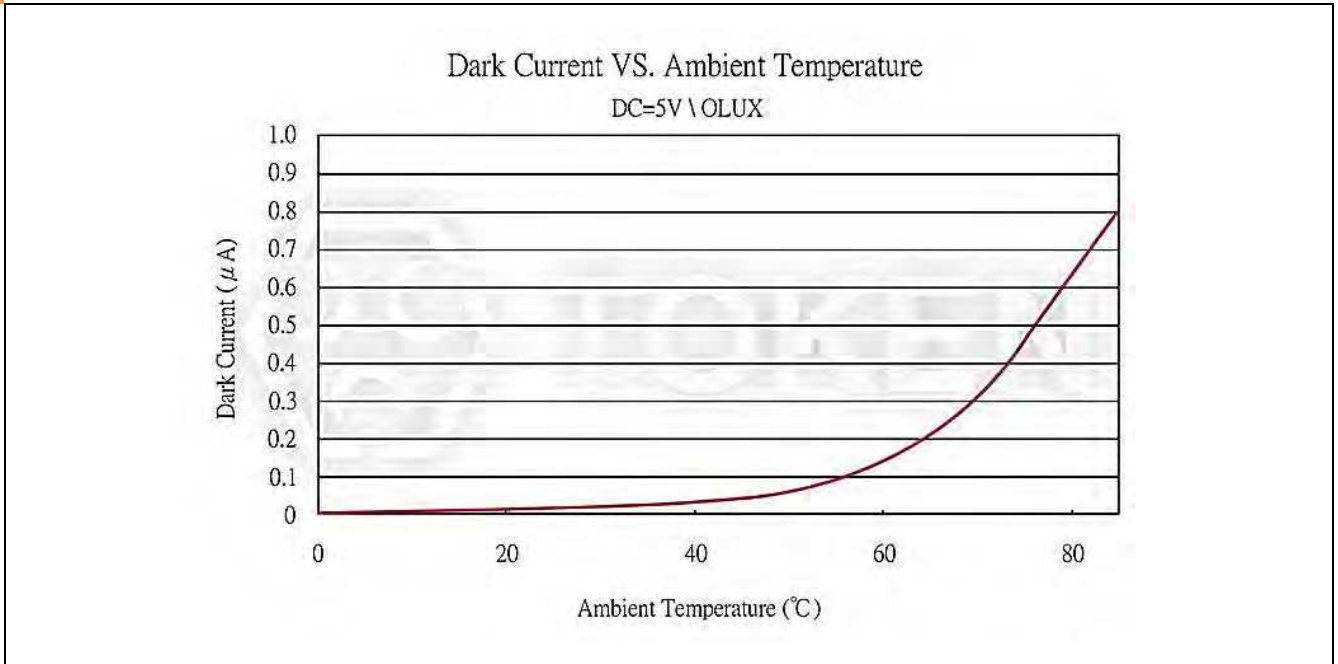

Photo Current vs. Illuminance (PT-IC-AC-5-PE-550)



Dark Current vs. Ambient Temperature (PT-IC-AC-5-PE-550)



▶ **BN Curve**

Relative Spectral Sensitivity vs. Wavelength (PT-IC-AC-5-BN-520)

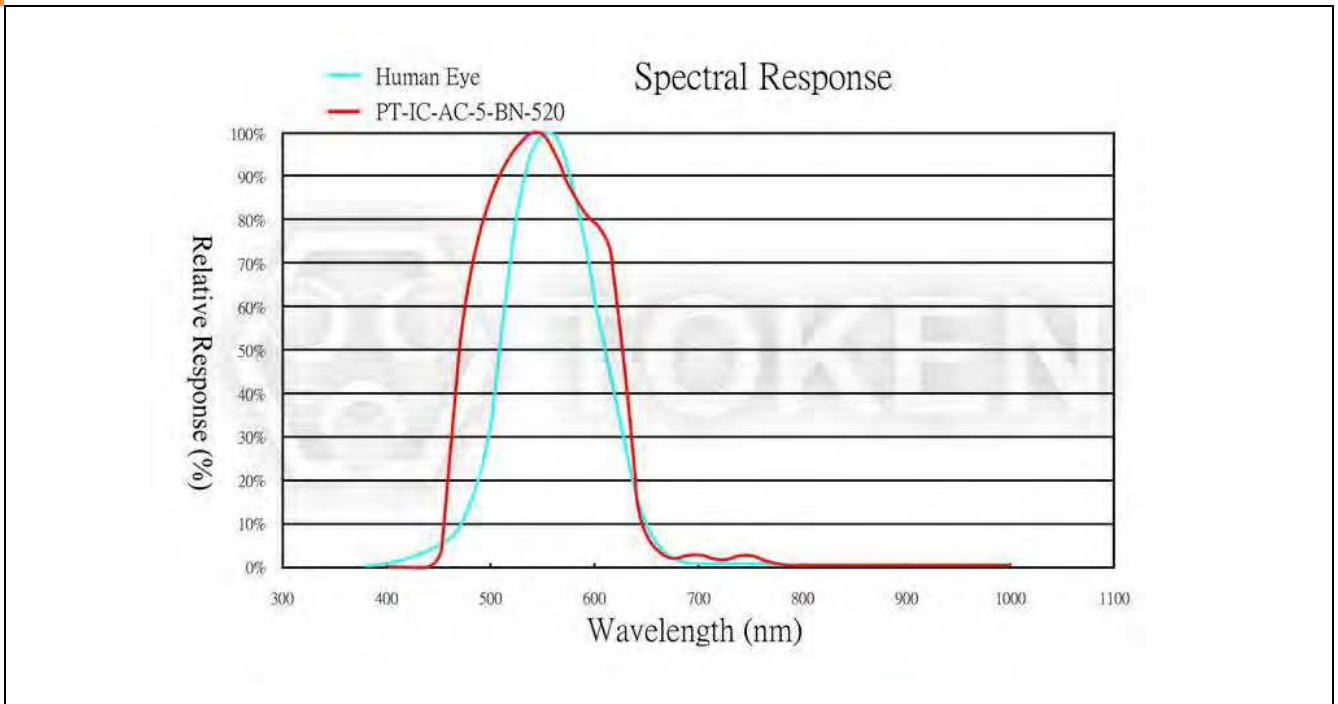
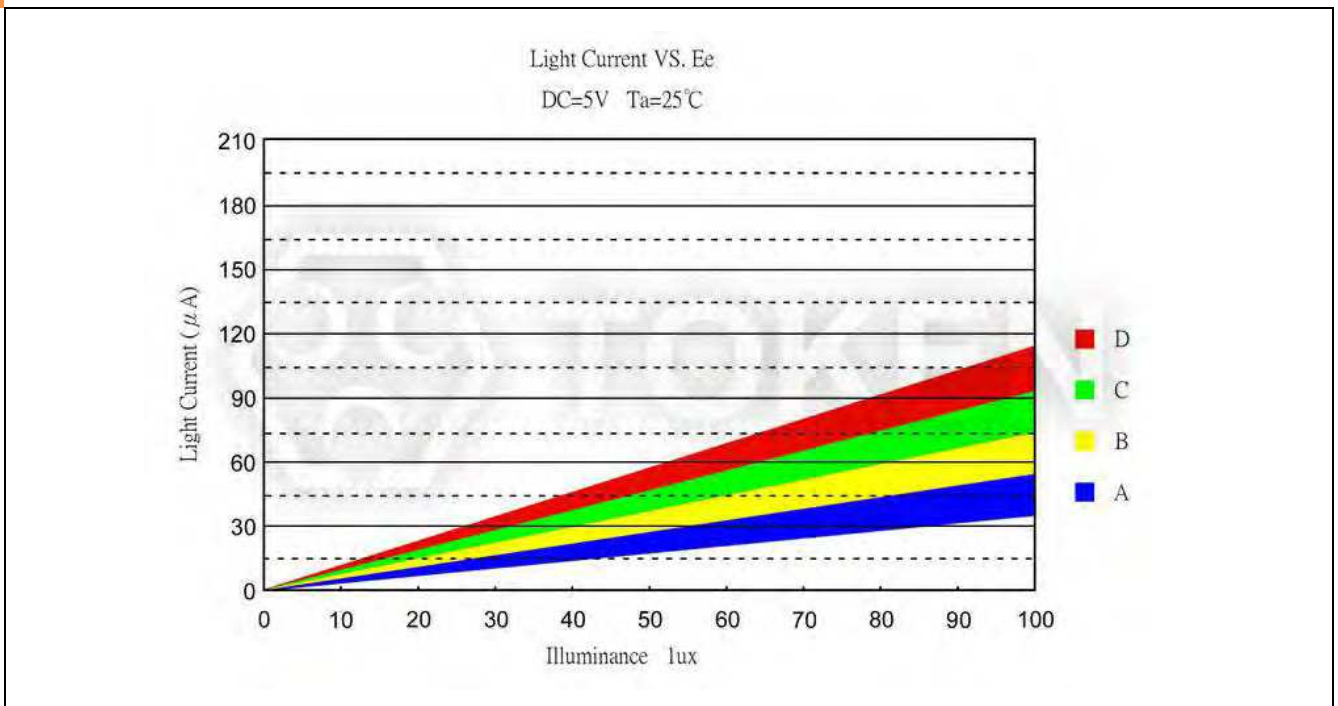
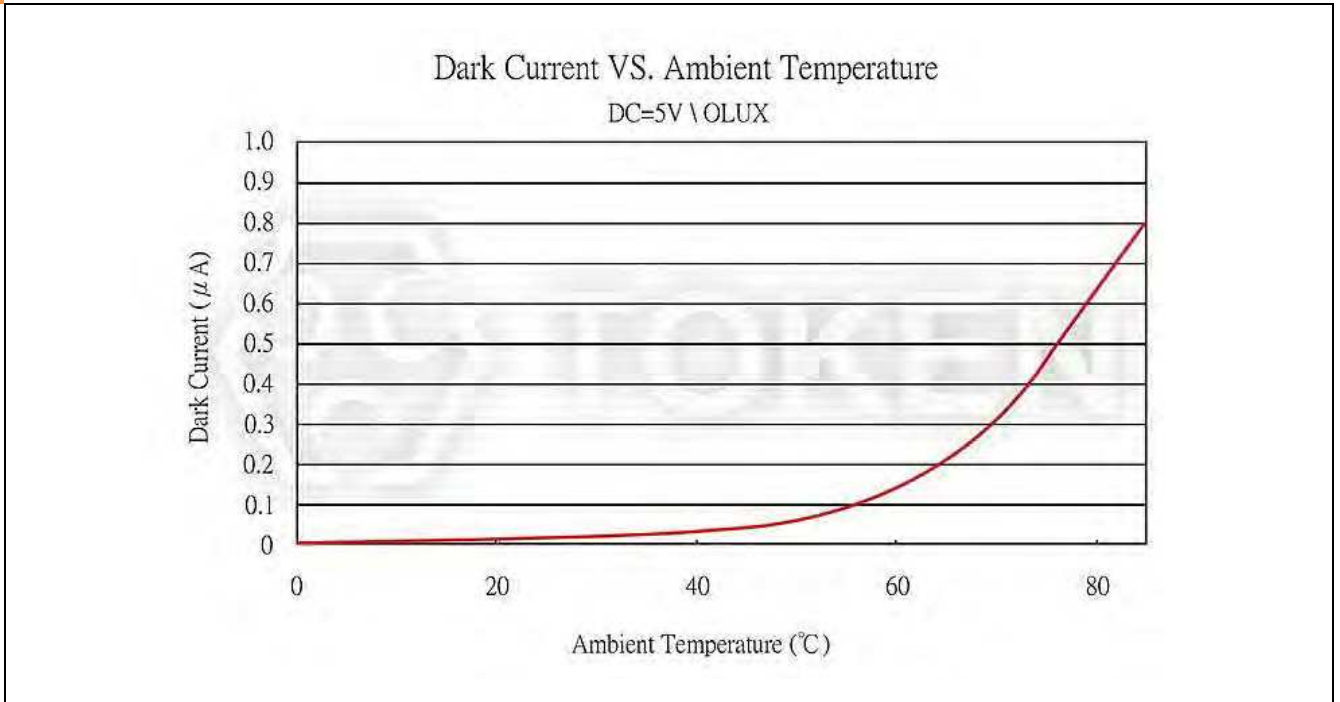

Photo Current vs. Illuminance (PT-IC-AC-5-BN-520)



Dark Current vs. Ambient Temperature (PT-IC-AC-5-BN-520)



▶ PN Curve

Relative Spectral Sensitivity vs. Wavelength (PT-IC-AC-5-PN-580)

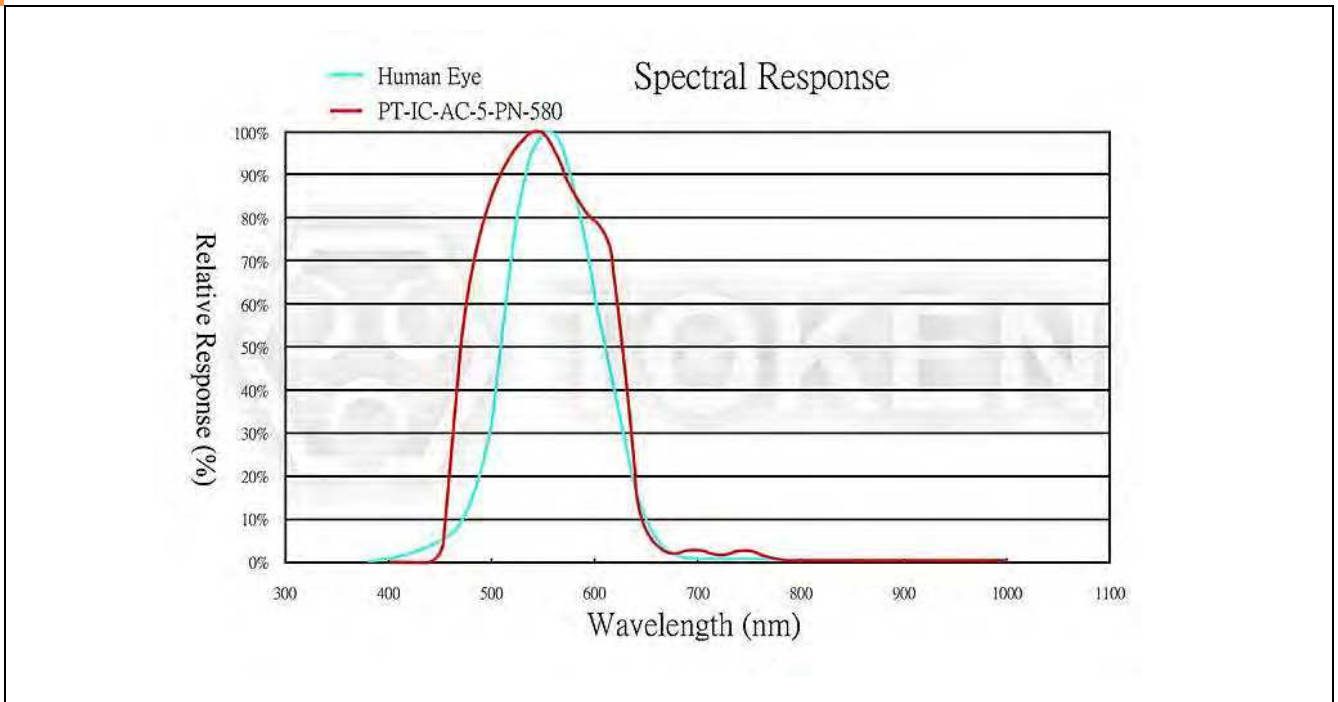
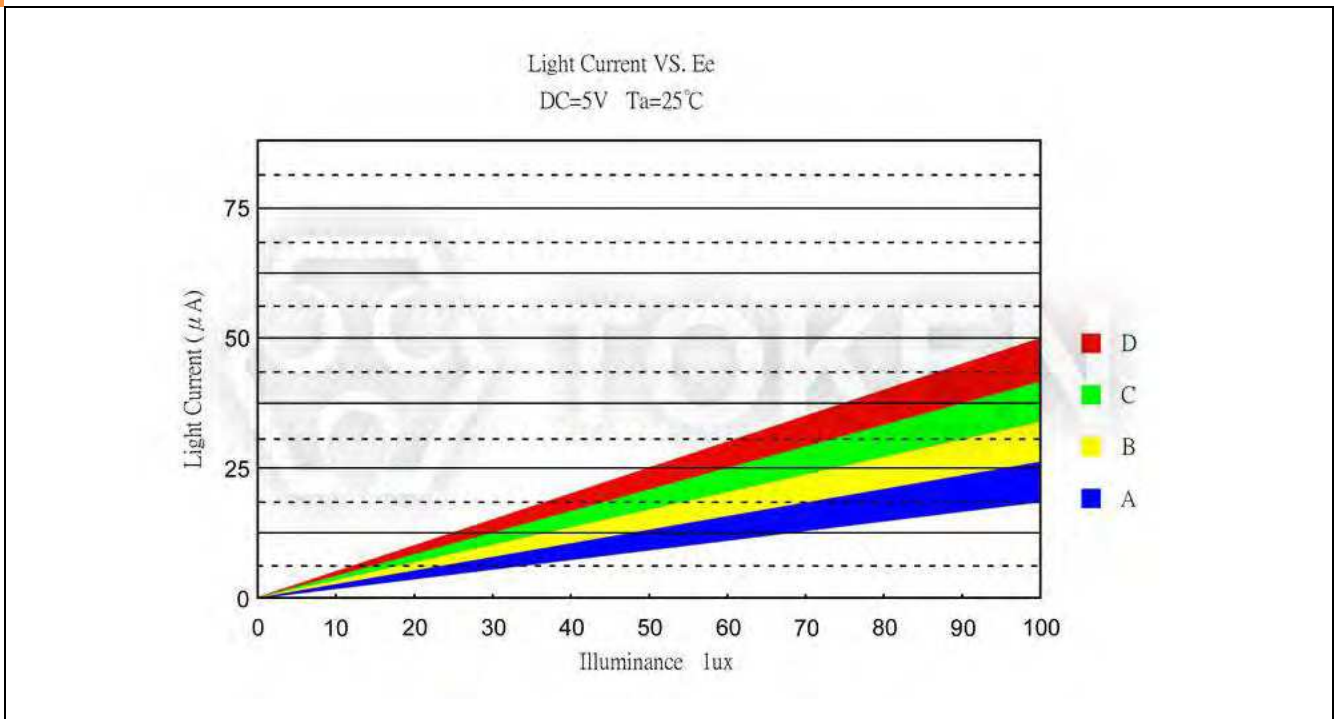
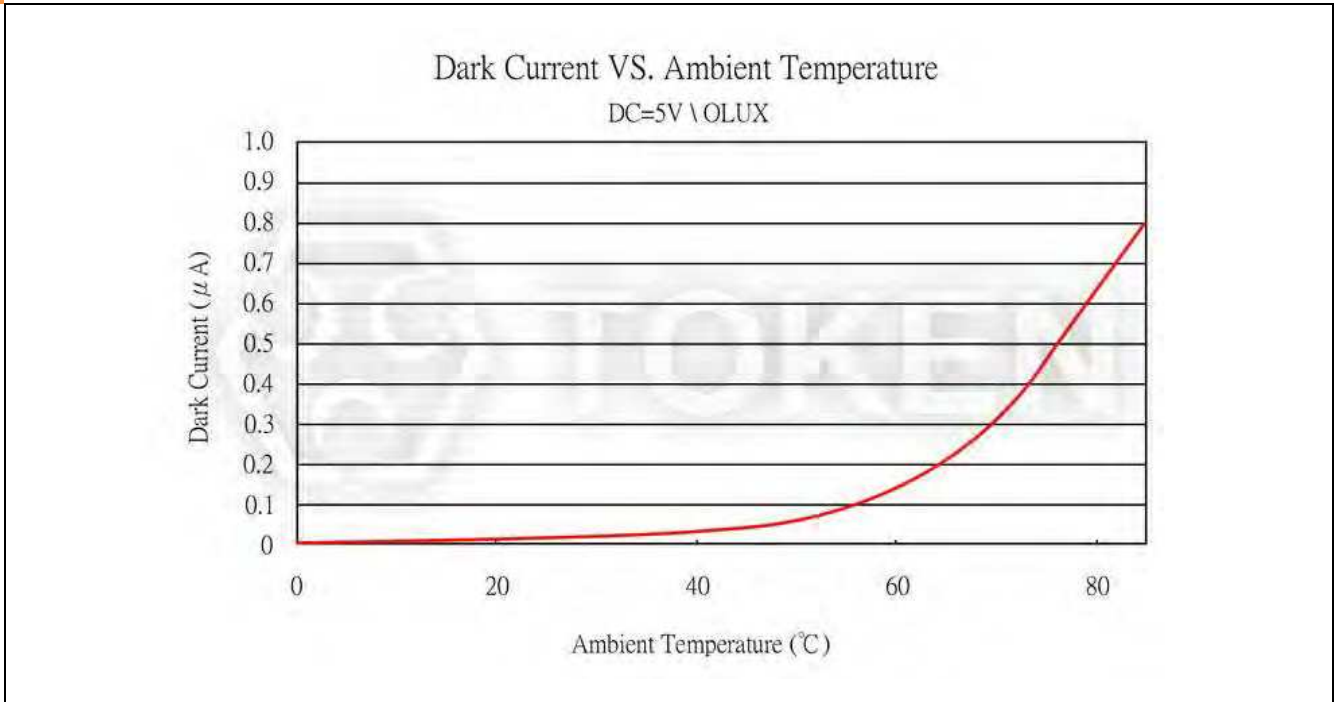

Photo Current vs. Illuminance (PT-IC-AC-5-PN-580)



Dark Current vs. Ambient Temperature (PT-IC-AC-5-PN-580)



Note

Visible Light Detector (PT-IC-AC) Precaution Usage :

- The light source : Select 590nm LED Surface light source.

Mounting :

- While packages are on one circuit board, avoid mismatching in the thermal expansion of each component, generate cracks in the package and break the bonding wire.

Soldering :

- Do not immerse plastic parts in tin tank.
- During soldering, when adding thermal stress in a moisture absorbing state, moisture evaporates, swells and generates stress to the internal package.
- To avoid swellings and cracks in the surface of the package, followsoldering conditions below.
- Wave soldering method: $120^{\circ}\text{C} < 60\text{s}$ 、 $260^{\circ}\text{C} < 5\text{s}$.
- Manual soldering: $260^{\circ}\text{C} < 5\text{s}$ 、 $340^{\circ}\text{C} < 3\text{s}$.

Lead-forming and cuttings :

- Before soldering, perform lead forming at normal temperature.
- While forming or cutting the lead, stay the area at a distance of 5 mm or greater from the root of the lead.
- Avoid mounting which may cause force on the root of the lead.

Storage :

The sensor is incorporated in the transparent resin package. Because of its sensitivity to humidity, the package is moisture-proof. When storing the sensor, do as instructed below.

- Quickly use after opening. (within 2 days, below $30^{\circ}\text{C}/60\% \text{ R.H.}$).
- Once unpacked, use within three months, or keeping within a moisture-proof method, which include maintaining within a moisture-proof container with silica gels, is suggested for longterm safe-keeping.
- Very bad storage conditions may deteriorate solderability or characteristics, and defect the appearance. Recommended conditions of the storage place, temperature 0°C to 30°C , humidity below 60% R.H. (Avoid freezingand dew condensation).

Cleaning :

- Do not wash with water to avoid corrosion.
- Under any circumstance, the cleaning time should be within 1 minute of normal temperature.
- Alcohol is recommended as a cleaning agent when cleaning products.
- If you use other cleaning agents, you need to confirm whether the cleaning agent will corrode the epoxy body.
- Freon can not be used as a cleaning agent.
- When cleaning products with ultrasonic cleaning, ultrasonic power and time should be less than 300W and 30 seconds, respectively.
- PCB and product can not touch the oscillator. Can not make the product on the PCB resonance.
- This model is static sensitive devices, so static electricity and surges can damage the product.
- To all the equipment, machines, tables, and the ground must be anti-static ground.
- Requires the use of anti-static wrist strap wear.

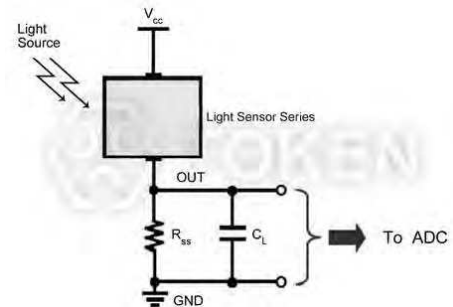

**Photo Current Measurement Method -
(PT-IC-AC)**

▶ Order Codes

Order Codes (PT-IC-AC)

PT		-	IC		-	AC		-	3		-	PE		-	550	
Part Number			Chip Type			Lens Color			Size			Shape			Spectral Bandwidth	
PT			IC			AC	Water Clear		3	3 mm		PE	Plate Edge		520	520 nm
									5	5 mm		BN	Bullet None		550	550 nm
												PN	Plate None		580	580 nm