



HESTORE.HU

elektronikai alkatrész áruház

EN: This Datasheet is presented by the manufacturer.

Please visit our website for pricing and availability at www.hestore.hu.

10 kPa On-Chip Temperature Compensated & Calibrated Silicon Pressure Sensors

The MPX2010/MPXV2010G series silicon piezoresistive pressure sensors provide a very accurate and linear voltage output — directly proportional to the applied pressure. These sensors house a single monolithic silicon die with the strain gauge and thin-film resistor network integrated on each chip. The sensor is laser trimmed for precise span, offset calibration and temperature compensation.

Features

- Temperature Compensated over 0°C to +85°C
- Ratiometric to Supply Voltage
- Differential and Gauge Options

Application Examples

- Respiratory Diagnostics
- Air Movement Control
- Controllers
- Pressure Switching

Figure 1 shows a block diagram of the internal circuitry on the stand-alone pressure sensor chip.

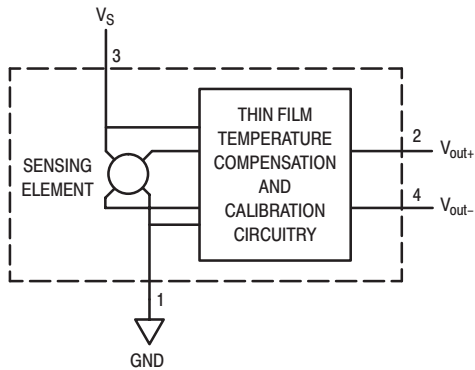

Figure 1. Temperature Compensated and Calibrated Pressure Sensor Schematic

VOLTAGE OUTPUT versus APPLIED DIFFERENTIAL PRESSURE

The output voltage of the differential or gauge sensor increases with increasing pressure applied to the pressure side (P1) relative to the vacuum side (P2). Similarly, output voltage increases as increasing vacuum is applied to the vacuum side (P2) relative to the pressure side (P1).

Preferred devices are Motorola recommended choices for future use and best overall value.

REV 9

MPX2010 MPXV2010G SERIES

Motorola Preferred Device

**COMPENSATED
PRESSURE SENSOR**
0 to 10 kPa (0 to 1.45 psi)
FULL SCALE SPAN: 25 mV

SMALL OUTLINE PACKAGE SURFACE MOUNT

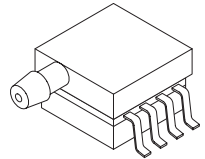

MPXV2010GP
CASE 1369

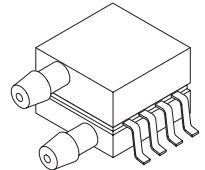

MPXV2010DP
CASE 1351

PIN NUMBER

1	Gnd	5	N/C
2	+V _{out}	6	N/C
3	V _S	7	N/C
4	-V _{out}	8	N/C

NOTE: Pin 1 is noted by the notch in the lead.

UNIBODY PACKAGE

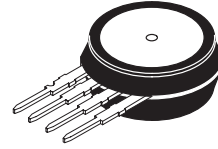

MPX2010D
CASE 344

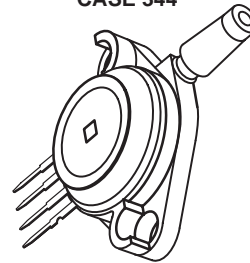

MPX2010GP
CASE 344B

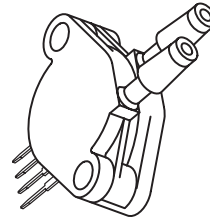

MPX2010DP
CASE 344C

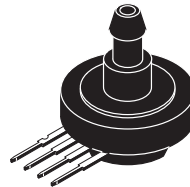

MPX2010GS
CASE 344E

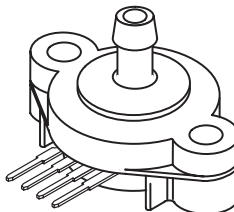

MPX2010GSX
CASE 344F

PIN NUMBER

1	Gnd	3	V _S
2	+V _{out}	4	-V _{out}

NOTE: Pin 1 is noted by the notch in the lead.

MPX2010 MPXV2010G SERIES

MAXIMUM RATINGS(NOTE)

Rating	Symbol	Value	Unit
Maximum Pressure (P1 > P2)	P_{max}	75	kPa
Storage Temperature	T_{stg}	-40 to +125	°C
Operating Temperature	T_A	-40 to +125	°C

NOTE: Exposure beyond the specified limits may cause permanent damage or degradation to the device.

OPERATING CHARACTERISTICS ($V_S = 10$ Vdc, $T_A = 25^\circ\text{C}$ unless otherwise noted, $P1 > P2$)

Characteristic	Symbol	Min	Typ	Max	Unit
Pressure Range ⁽¹⁾	P_{OP}	0	—	10	kPa
Supply Voltage ⁽²⁾	V_S	—	10	16	Vdc
Supply Current	I_o	—	6.0	—	mAdc
Full Scale Span ⁽³⁾	V_{FSS}	24	25	26	mV
Offset ⁽⁴⁾	V_{off}	-1.0	—	1.0	mV
Sensitivity	$\Delta V/\Delta P$	—	2.5	—	mV/kPa
Linearity ⁽⁵⁾	—	-1.0	—	1.0	% V_{FSS}
Pressure Hysteresis ⁽⁵⁾ (0 to 10 kPa)	—	—	± 0.1	—	% V_{FSS}
Temperature Hysteresis ⁽⁵⁾ (-40°C to +125°C)	—	—	± 0.5	—	% V_{FSS}
Temperature Effect on Full Scale Span ⁽⁵⁾	TCV_{FSS}	-1.0	—	1.0	% V_{FSS}
Temperature Effect on Offset ⁽⁵⁾	TCV_{off}	-1.0	—	1.0	mV
Input Impedance	Z_{in}	1000	—	2550	Ω
Output Impedance	Z_{out}	1400	—	3000	Ω
Response Time ⁽⁶⁾ (10% to 90%)	t_R	—	1.0	—	ms
Warm-Up	—	—	20	—	ms
Offset Stability ⁽⁷⁾	—	—	± 0.5	—	% V_{FSS}

NOTES:

- 1.0 kPa (kiloPascal) equals 0.145 psi.
- Device is ratiometric within this specified excitation range. Operating the device above the specified excitation range may induce additional error due to device self-heating.
- Full Scale Span (V_{FSS}) is defined as the algebraic difference between the output voltage at full rated pressure and the output voltage at the minimum rated pressure.
- Offset (V_{off}) is defined as the output voltage at the minimum rated pressure.
- Accuracy (error budget) consists of the following:
 - Linearity: Output deviation from a straight line relationship with pressure, using end point method, over the specified pressure range.
 - Temperature Hysteresis: Output deviation at any temperature within the operating temperature range, after the temperature is cycled to and from the minimum or maximum operating temperature points, with zero differential pressure applied.
 - Pressure Hysteresis: Output deviation at any pressure within the specified range, when this pressure is cycled to and from the minimum or maximum rated pressure, at 25°C.
 - TcSpan: Output deviation at full rated pressure over the temperature range of 0 to 85°C, relative to 25°C.
 - TcOffset: Output deviation with minimum rated pressure applied, over the temperature range of 0 to 85°C, relative to 25°C.
- Response Time is defined as the time for the incremental change in the output to go from 10% to 90% of its final value when subjected to a specified step change in pressure.
- Offset stability is the product's output deviation when subjected to 1000 hours of Pulsed Pressure, Temperature Cycling with Bias Test.

ON-CHIP TEMPERATURE COMPENSATION and CALIBRATION

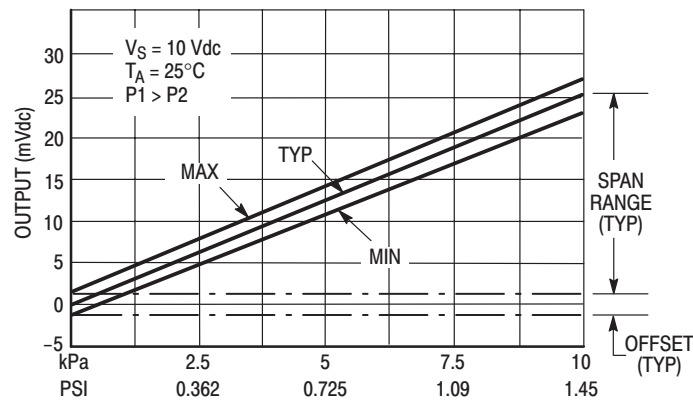

Figure 2. Output versus Pressure Differential

Figure 2 shows the output characteristics of the MPX2010/MPXV2010G series at 25°C. The output is directly proportional to the differential pressure and is essentially a straight line.

The effects of temperature on full scale span and offset are very small and are shown under Operating Characteristics.

This performance over temperature is achieved by having both the shear stress strain gauge and the thin-film resistor circuitry on the same silicon diaphragm. Each chip is dynamically laser trimmed for precise span and offset calibration and temperature compensation.

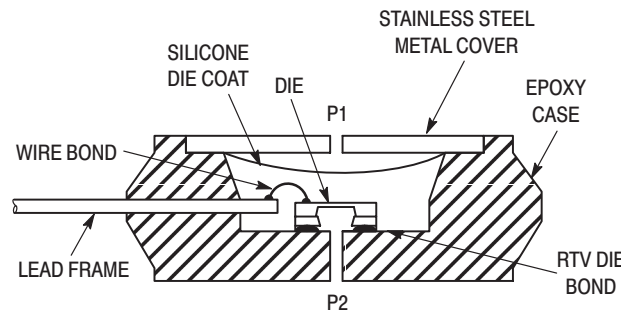

Figure 3. Unibody Package — Cross-Sectional Diagram (not to scale)

Figure 3 illustrates the differential/gauge die in the basic chip carrier (Case 344). A silicone gel isolates the die surface and wire bonds from the environment, while allowing the pressure signal to be transmitted to the silicon diaphragm.

The MPX2010/MPXV2010G series pressure sensor oper-

ating characteristics and internal reliability and qualification tests are based on use of dry air as the pressure media. Media other than dry air may have adverse effects on sensor performance and long term reliability. Contact the factory for information regarding media compatibility in your application.

MPX2010 MPXV2010G SERIES

LINEARITY

Linearity refers to how well a transducer's output follows the equation: $V_{out} = V_{off} + \text{sensitivity} \times P$ over the operating pressure range. There are two basic methods for calculating nonlinearity: (1) end point straight line fit (see Figure 5) or (2) a least squares best line fit. While a least squares fit gives the "best case" linearity error (lower numerical value), the calculations required are burdensome.

Conversely, an end point fit will give the "worst case" error (often more desirable in error budget calculations) and the calculations are more straightforward for the user. Motorola's specified pressure sensor linearities are based on the end point straight line method measured at the midrange pressure.

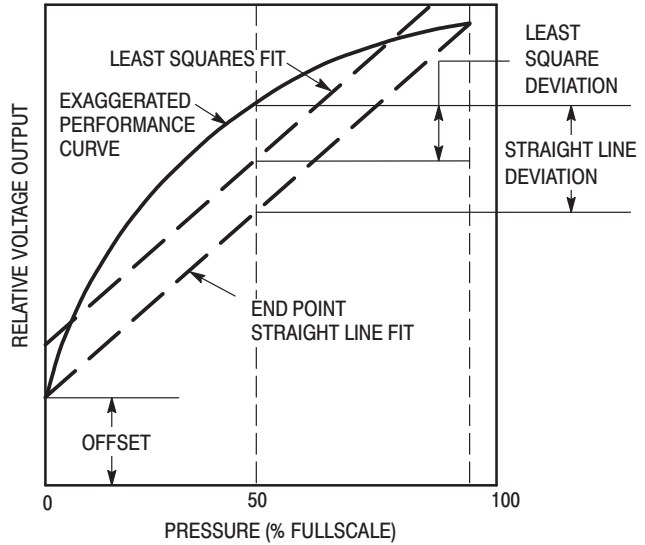

Figure 4. Linearity Specification Comparison

PRESSURE (P1)/VACUUM (P2) SIDE IDENTIFICATION TABLE

Motorola designates the two sides of the pressure sensor as the Pressure (P1) side and the Vacuum (P2) side. The Pressure (P1) side is the side containing silicone gel which isolates the die from the environment. The Motorola MPX

pressure sensor is designed to operate with positive differential pressure applied, $P1 > P2$.

The Pressure (P1) side may be identified by using the table below:

Part Number	Case Type	Pressure (P1) Side Identifier
MPX2010D	344	Stainless Steel Cap
MPX2010DP	344C	Side with Part Marking
MPX2010GP	344B	Side with Port Attached
MPX2010GS	344E	Side with Port Attached
MPX2010GSX	344F	Side with Port Attached
MPXV2010GP	1369	Side with Port Attached
MPXV2010DP	1351	Side with Part Marking

ORDERING INFORMATION — UNIBODY PACKAGE (MPX2010 SERIES)

Device Type	Options	Case Type	MPX Series	
			Order Number	Device Marking
Basic Element	Differential	344	MPX2010D	MPX2010D
Ported Elements	Differential, Dual Port	344C	MPX2010DP	MPX2010DP
	Gauge	344B	MPX2010GP	MPX2010GP
	Gauge, Axial	344E	MPX2010GS	MPX2010D
	Gauge, Axial PC Mount	344F	MPX2010GSX	MPX2010D

ORDERING INFORMATION — SMALL OUTLINE PACKAGE (MPXV2010G SERIES)

Device Type	Options	Case No.	MPX Series Order No.	Packing Options	Marking
Ported Elements	Gauge, Side Port, SMT	1369	MPXV2010GP	Trays	MPXV2010G
	Differential, Dual Port, SMT	1351	MPXV2010DP	Trays	MPXV2010G

SMALL OUTLINE PACKAGE DIMENSIONS

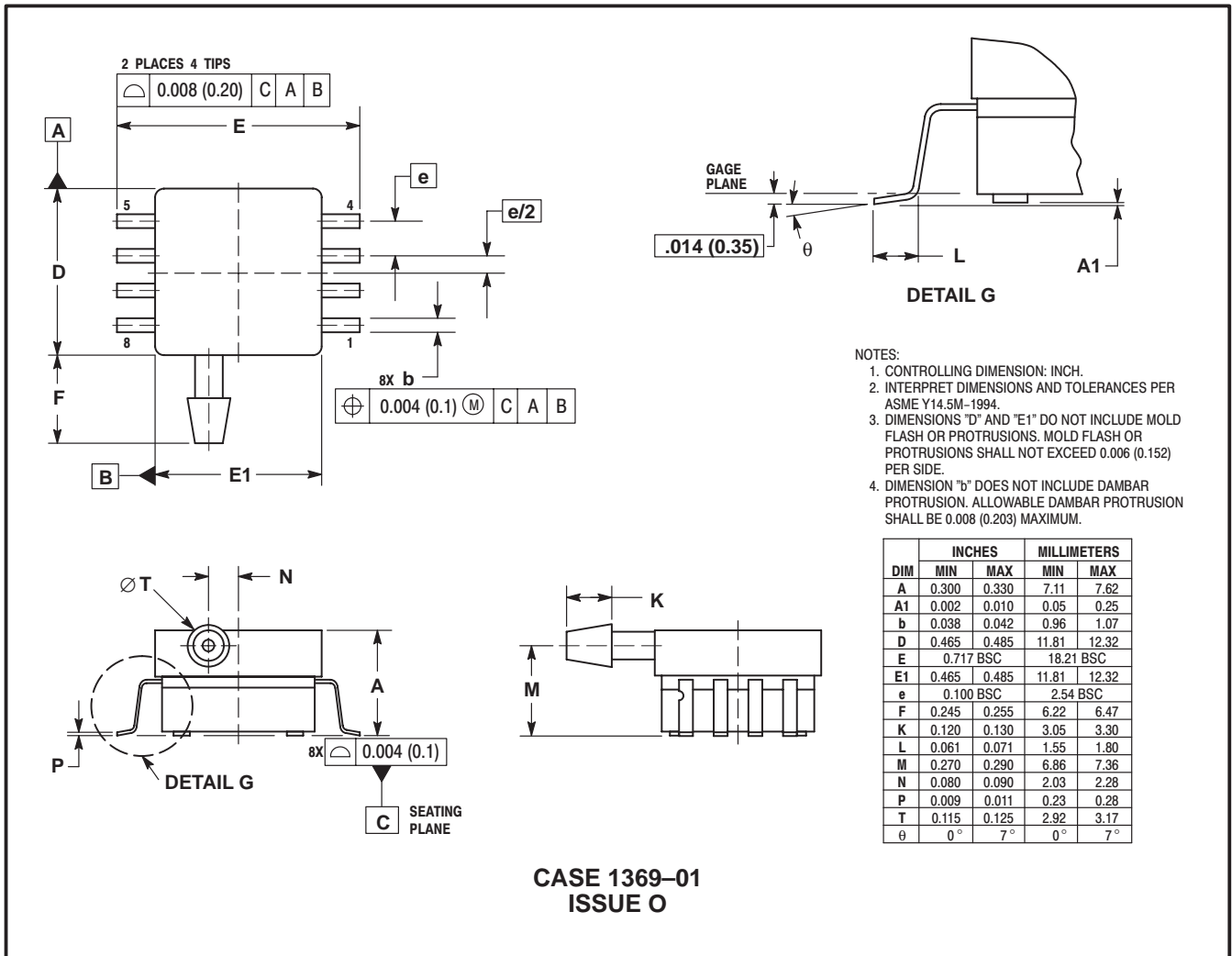

MPX2010 MPXV2010G SERIES

SMALL OUTLINE PACKAGE DIMENSIONS—CONTINUED

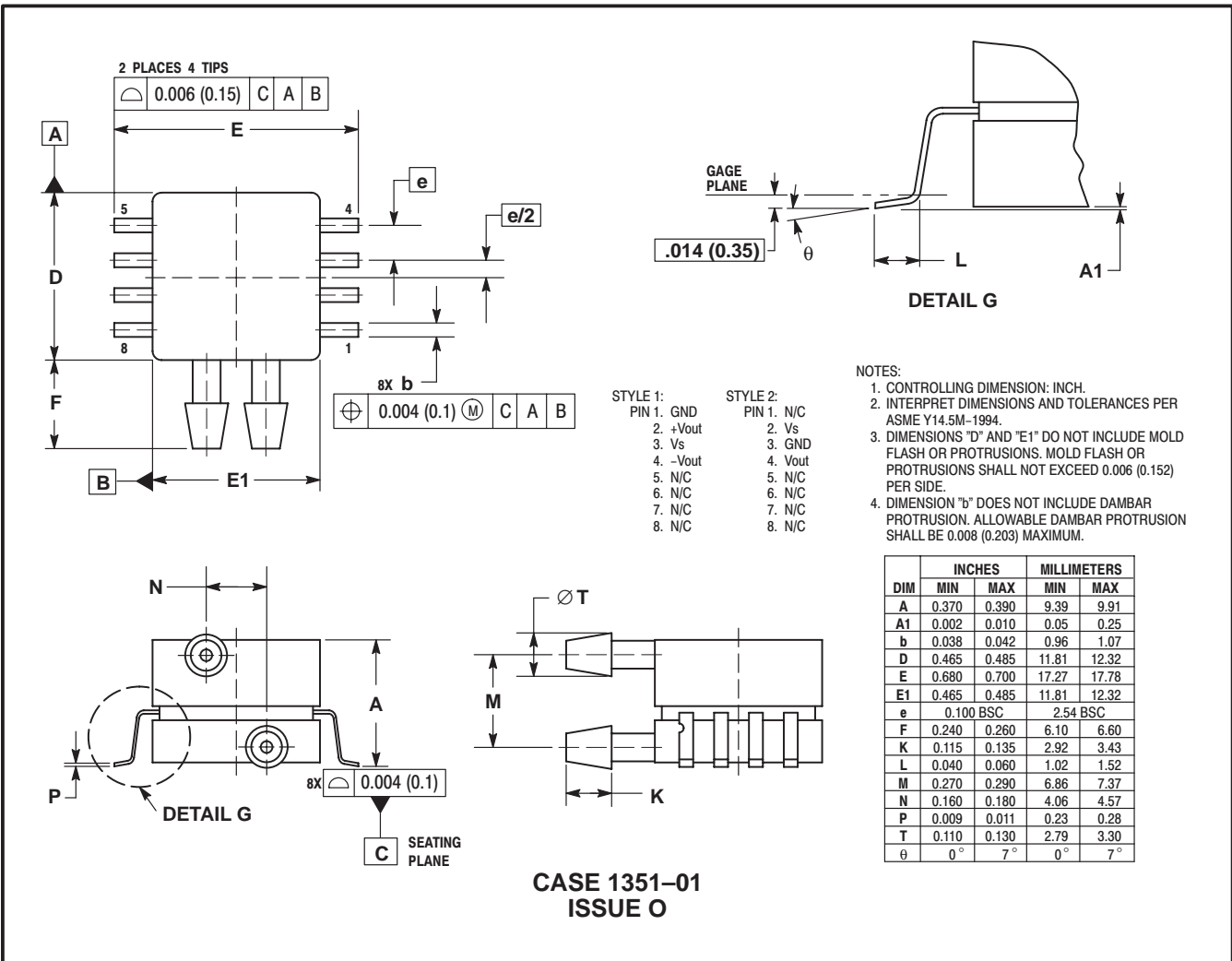

UNIBODY PACKAGE DIMENSIONS

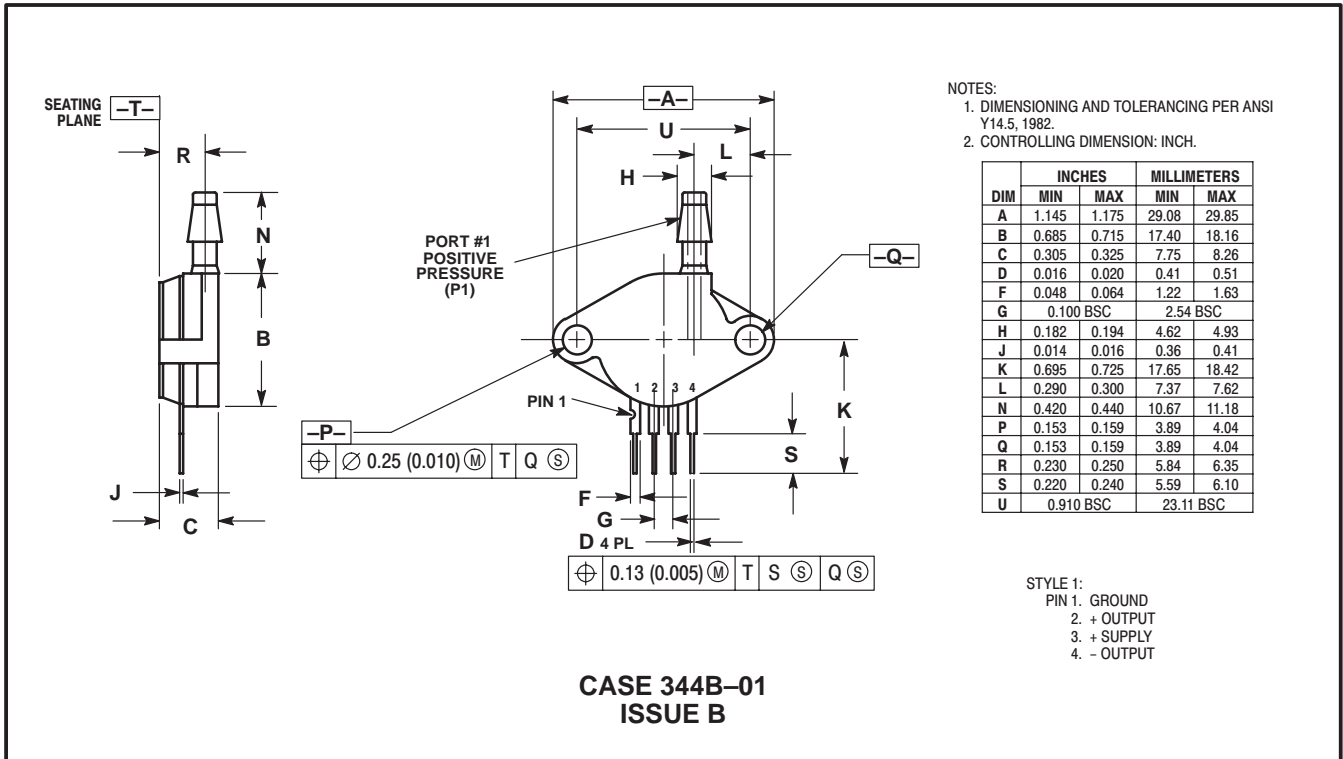
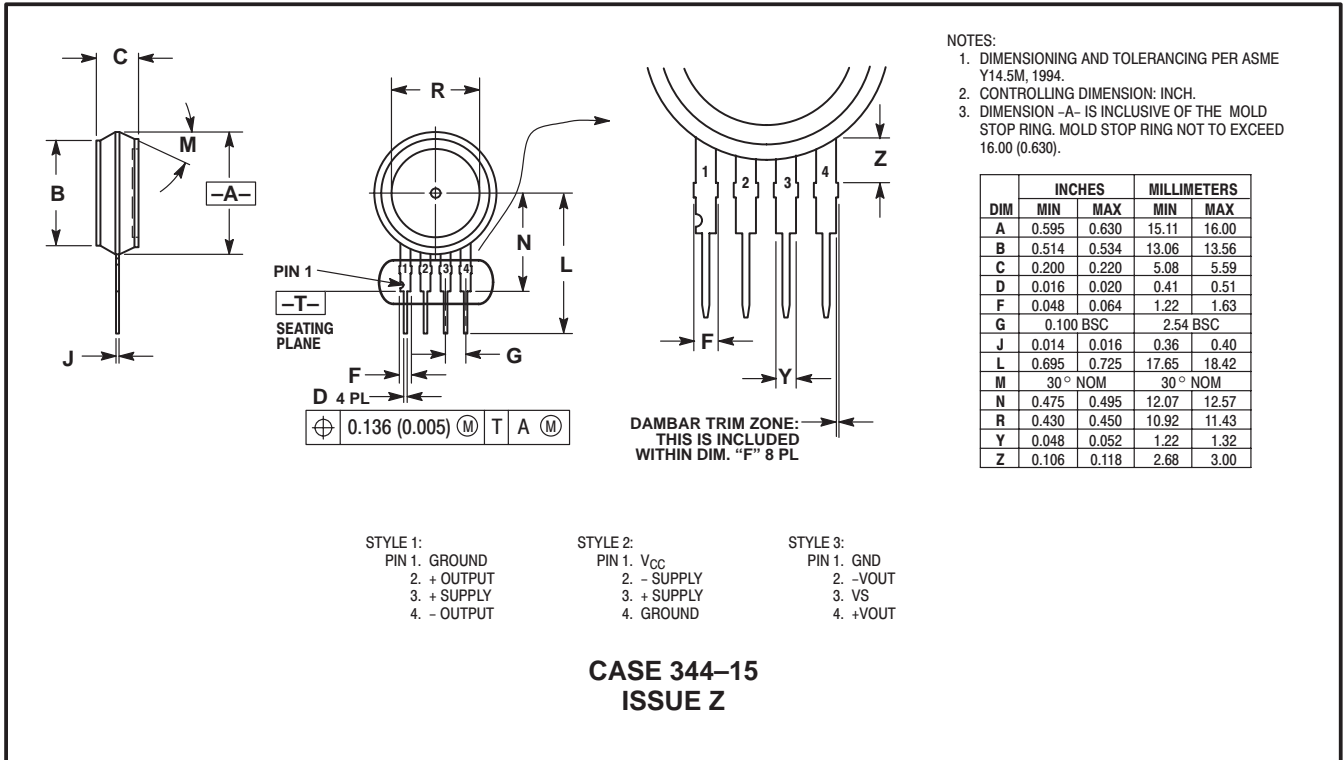

MPX2010 MPXV2010G SERIES

UNIBODY PACKAGE DIMENSIONS — CONTINUED

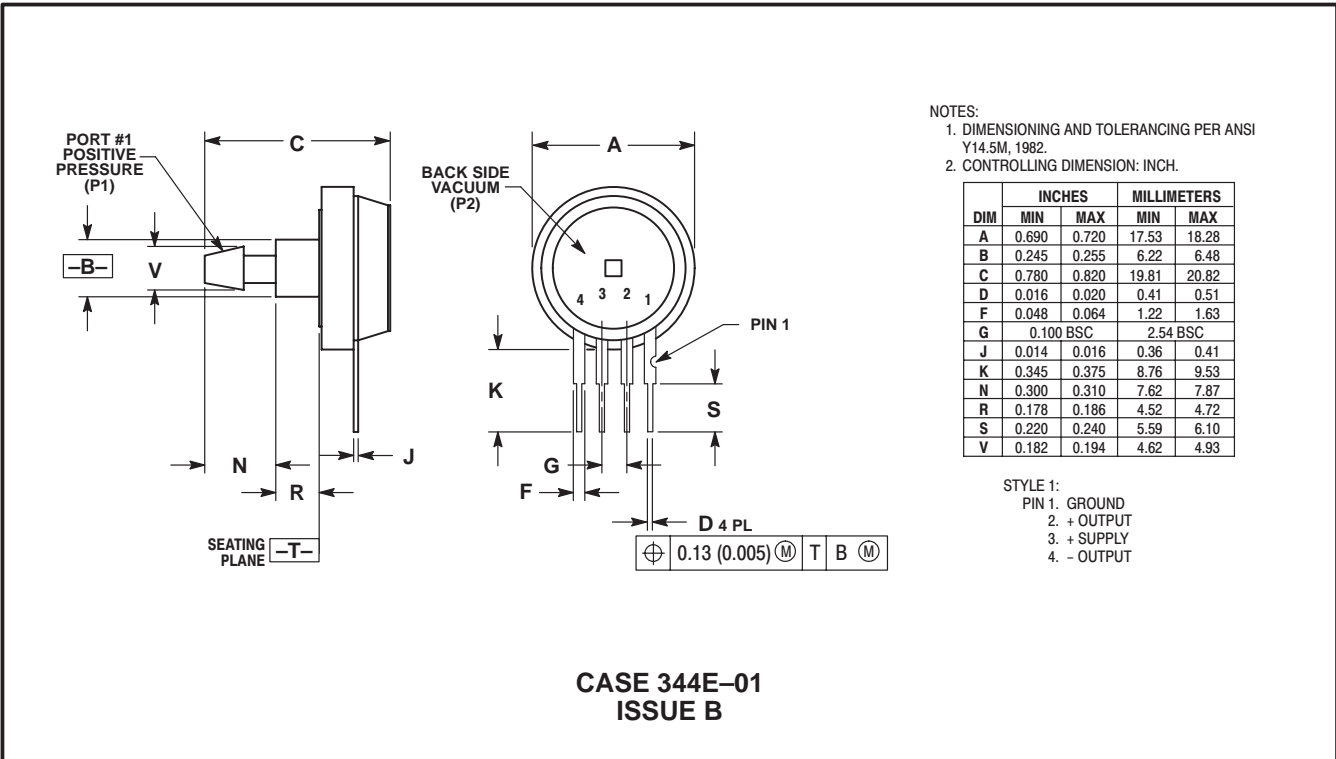
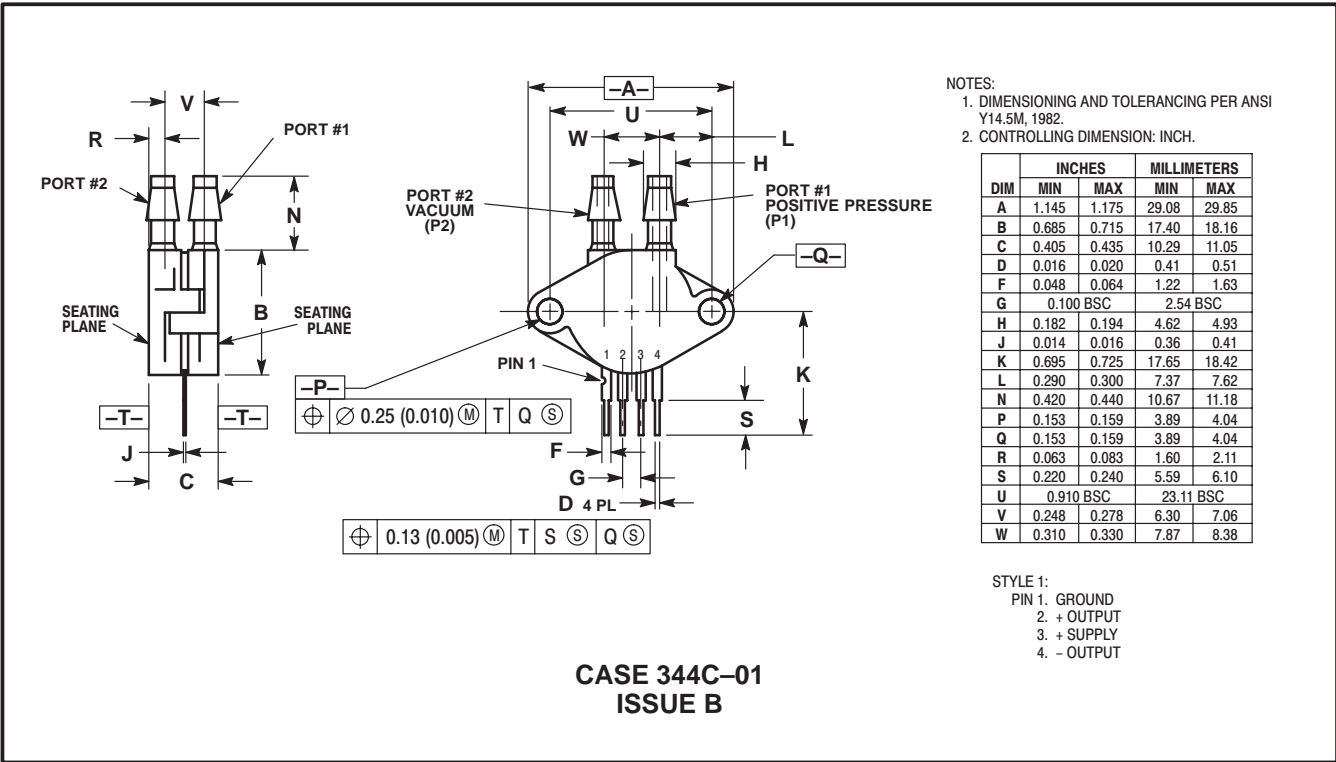

UNIBODY PACKAGE DIMENSIONS — CONTINUED

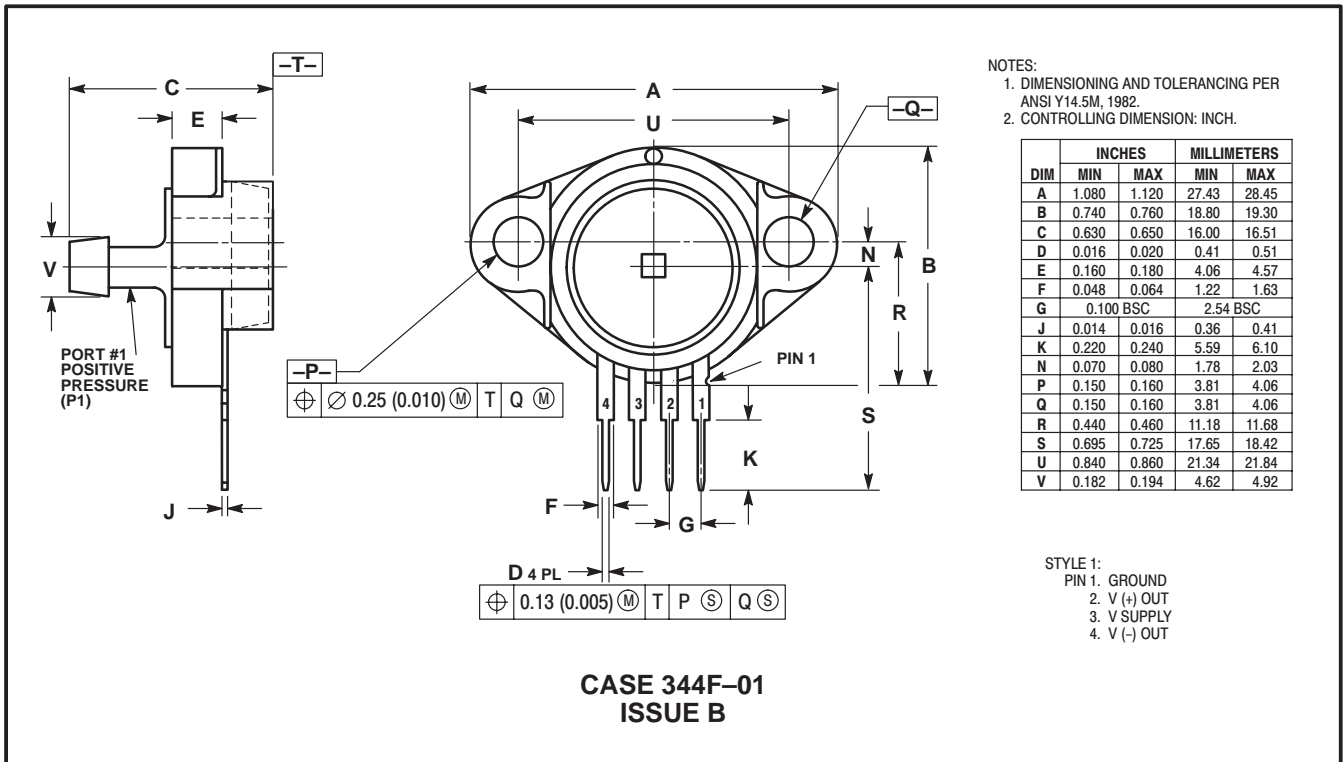

NOTES

NOTES

MPX2010 MPXV2010G SERIES

Motorola reserves the right to make changes without further notice to any products herein. Motorola makes no warranty, representation or guarantee regarding the suitability of its products for any particular purpose, nor does Motorola assume any liability arising out of the application or use of any product or circuit, and specifically disclaims any and all liability, including without limitation consequential or incidental damages. "Typical" parameters can and do vary in different applications and actual performance may vary over time. All operating parameters, including "Typicals" must be validated for each customer application by customer's technical experts. Motorola does not convey any license under its patent rights nor the rights of others. Motorola products are not designed, intended, or authorized for use as components in systems intended for surgical implant into the body, or other applications intended to support or sustain life, or for any other application in which the failure of the Motorola product could create a situation where personal injury or death may occur. Should Buyer purchase or use Motorola products for any such unintended or unauthorized application, Buyer shall indemnify and hold Motorola and its officers, employees, subsidiaries, affiliates, and distributors harmless against all claims, costs, damages, and expenses, and reasonable attorney fees arising out of, directly or indirectly, any claim of personal injury or death associated with such unintended or unauthorized use, even if such claim alleges that Motorola was negligent regarding the design or manufacture of the part. Motorola and the Stylized M Logo are registered trademarks of Motorola, Inc. Motorola, Inc. is an Equal Opportunity/Affirmative Action Employer.

MOTOROLA and the Stylized M Logo are registered in the US Patent & Trademark Office. All other product or service names are the property of their respective owners.

© Motorola, Inc. 2002.

How to reach us:

USA/EUROPE/Locations Not Listed: Motorola Literature Distribution; P.O. Box 5405, Denver, Colorado 80217. 1-303-675-2140 or 1-800-441-2447

JAPAN: Motorola Japan Ltd.; SPS, Technical Information Center, 3-20-1, Minami-Azabu, Minato-ku, Tokyo 106-8573 Japan. 81-3-3440-3569

ASIA/PACIFIC: Motorola Semiconductors H.K. Ltd.; Silicon Harbour Centre, 2 Dai King Street, Tai Po Industrial Estate, Tai Po, N.T., Hong Kong. 852-26668334

Technical Information Center: 1-800-521-6274

HOME PAGE: <http://www.motorola.com/semiconductors/>



MOTOROLA



MPX2010/D