



HESTORE.HU

elektronikai alkatrész áruház

EN: This Datasheet is presented by the manufacturer.

Please visit our website for pricing and availability at www.hestore.hu.

INFRARED RECEIVER MODULE

● Description

The OS-1838B is miniaturized infrared receivers for remote control and other applications requiring improved ambient light rejection.

The separate PIN diode and preamplifier IC are assembled on a single leadframe.

The epoxy package contains a special IR filter.

This module has excellent performance even in disturbed ambient light applications and provides protection against uncontrolled output pulses.



● Features

- Photo detector and preamplifier in one package .
- Internal filter for PCM frequency.
- Inner shield,good anti-interference ability.
- High immunity against ambient light.
- Improved shielding against electric field disturbance
- 3.0V or 5.0V supply voltage; low power consumption.
- TTL and CMOS compatibility.
- Suitable transmission code:NEC code,RC5 code.

● Applications:

1. Optical switch
2. Light detecting protion of remote contol
 - AV instruments such as Audio,TV,VCR,CD,MD,DVD,etc.
 - Home appliances such as Air-conditioner,Fan,etc.
 - CATV set top boxes
 - Multi-media Equipment

● Absolute Maximum Ratings (Ta=25°C)

| Parameter | Symbol | Ratings | Unit | Notice |
|-----------------------|------------------|---------|------|---------------------------------------|
| Supply Voltage | V _s | 2.7-5.5 | V | — |
| Operating Temperature | T _{opr} | -20~+65 | °C | — |
| Storage Temperature | T _{stg} | -40~+85 | °C | — |
| Soldering Temperature | T _{sd} | 260 | °C | 4mm from mold body less than 5 sec |

OS-1838B

● Electrical And Optical Characteristics (Ta=25°C)

| Parameter | Symbol | Ratings | | | Unit | Condition |
|---------------------------|-----------------|---------|------|------|------|---|
| | | Min. | Typ. | Max. | | |
| Supply Voltage | V _s | 2.7 | -- | 5.5 | V | |
| Supply Current | I _{cc} | — | 0.35 | 0.6 | mA | I _{in} =0uA, V _{cc} =5V |
| Reception Distance | L ₀ | 18 | — | — | m | At the ray axis*1 |
| | L ₃₅ | 12 | — | — | | |
| B.P.F Center Frequency | f _o | — | 38 | — | KHz | |
| Peak Wavelength | λ _p | — | 940 | — | nm | |
| Half Angle | λ ± | — | 35 | — | deg | At the ray axis *1 |
| High Level Pulse Width | T _H | 450 | 600 | 750 | μS | At the ray axis *2 |
| Low Level Pulse Width | T _L | 450 | 600 | 750 | μS | |
| High Level Output Voltage | V _H | 4.5 | — | — | V | |
| Low Level Output Voltage | V _L | — | — | 0.5 | V | |

*1: The ray receiving surface at a vertex and relation to the ray axis in the range of $\theta=0^\circ$ and $\theta=45^\circ$

*2: A range from 30cm to the arrival distance. Average value of 50 pulses

● BLOCK DIAGRAM

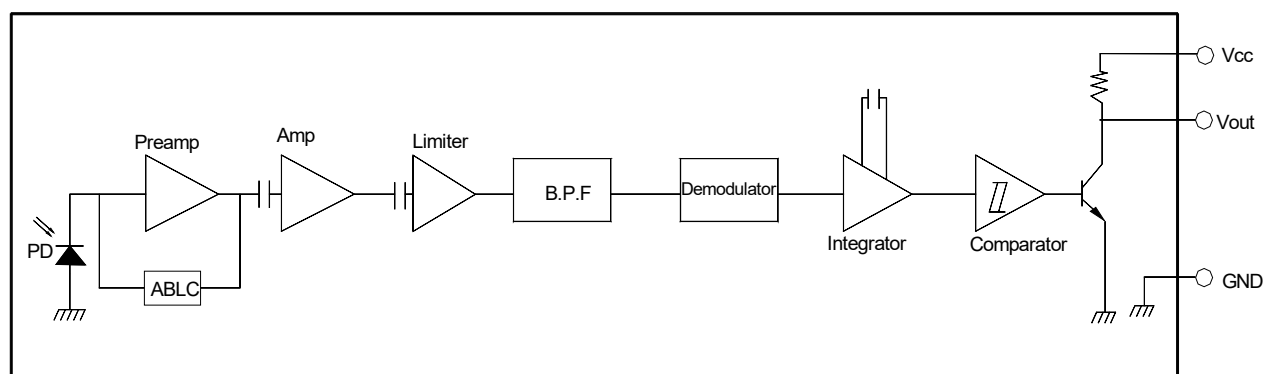

● Test Method

OS-1838B

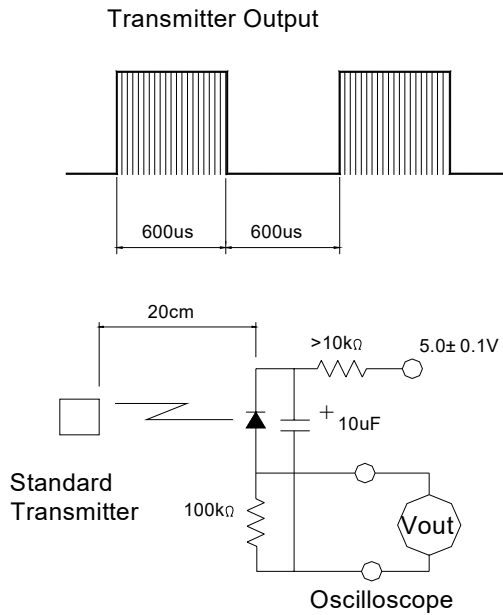
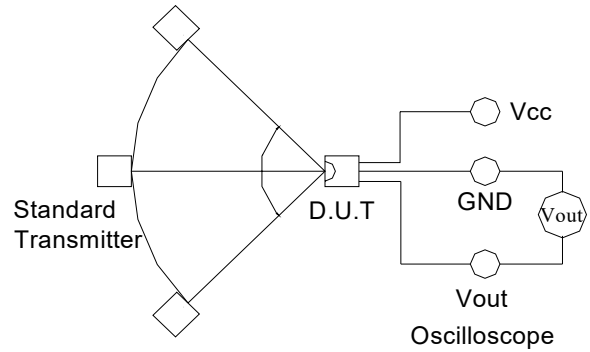
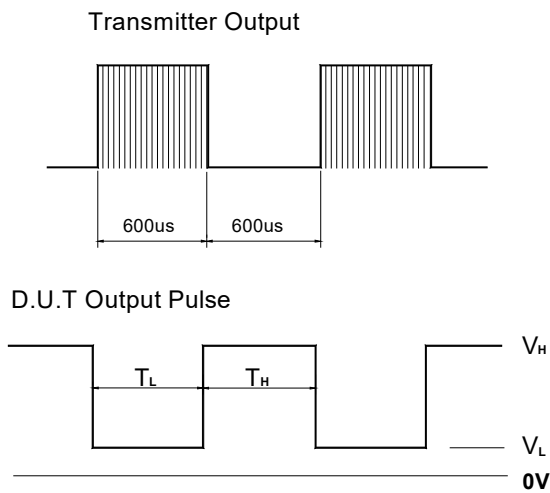
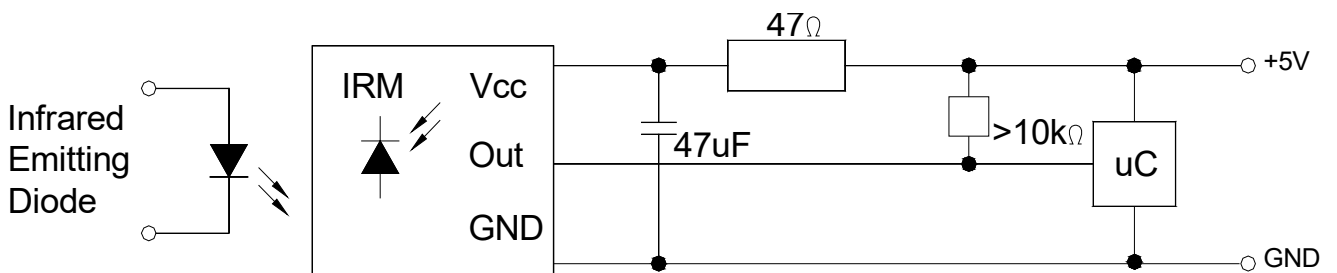
A. Standard Transmitter

B. Detection Length Test

C. Pulse Width Test

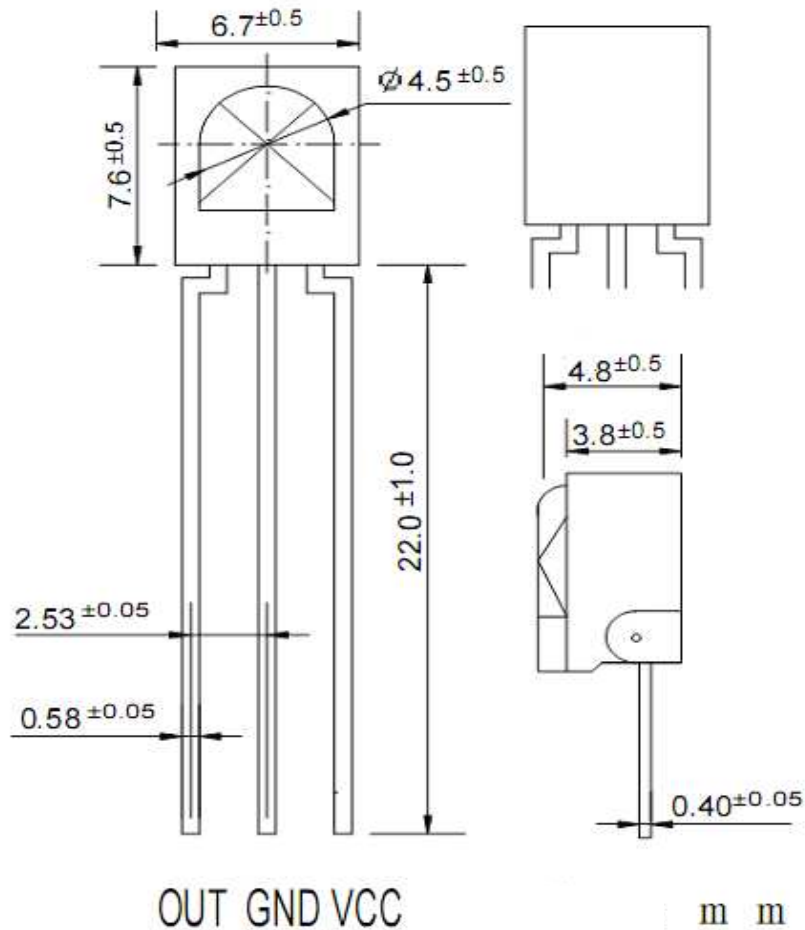
● Application Circuit

OS-1838B

● Package Dimensions:



NOTES:

1. All dimensions are in millimeters (inches).
2. Tolerance is $\pm 0.30\text{mm}$ (0.012") unless otherwise specified.
3. Specifications are subject to change without notice.

OS-1838B

● Electrical And Optical Curves(Ta=25°C)

Fig.1 Relative Spectral Sensitivity vs. Wavelength

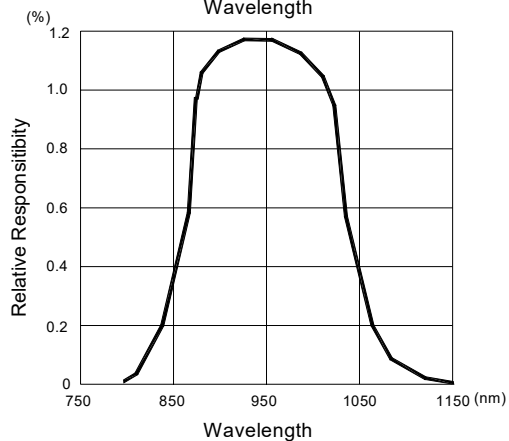

Fig.2 Relative Transmission Distance Vs. Direction

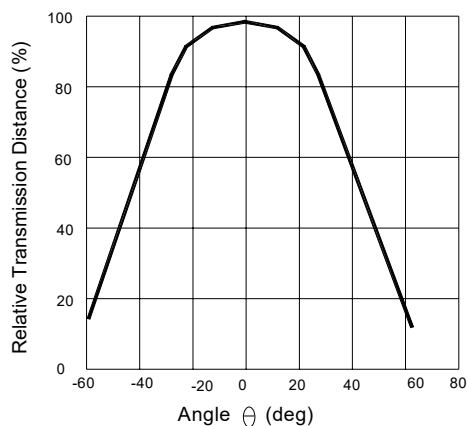

Fig.3 Frequency Dependence of Responsivity

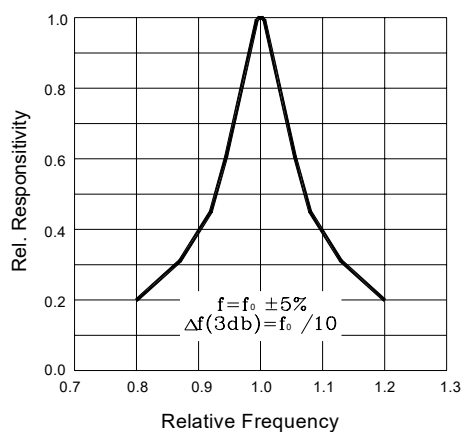

Fig.4 Supply Current vs. Ambient Temperature

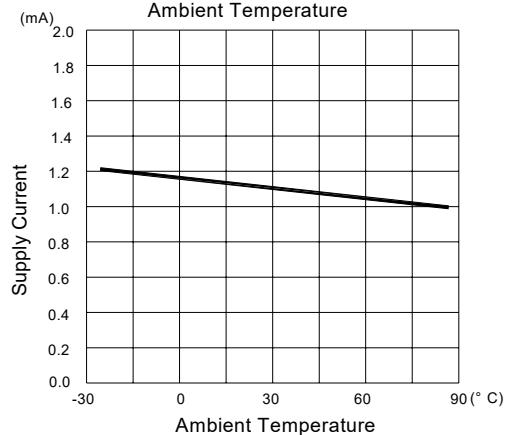

Fig.5 Relative Transmission Distance vs. Direction

