



HESTORE.HU

elektronikai alkatrész áruház

EN: This Datasheet is presented by the manufacturer.

Please visit our website for pricing and availability at www.hestore.hu.

REV.	DESCRIPTION	DRAWN	CHECKED	APPROVED
A	NEW RELEASE	LL 07/03/06'	~	LJC 04/04/06'
F	ADD DIM	LL 11/16/06'	~	LJC 11/05/06'
H	ADD DIM	LL 11/29/06'	~	LJC 11/29/06'
J	ADD DIM	YCH 09/12/07'	~	LJC 09/24/07'
K	ADD DIM	YCH 09/12/07'	~	LJC 01/27/10'
L	ADD DIM	DGQ 03/18/11'	~	LJC 01/27/10'
N	ADD DIM	JLZ 10/06/14'	~	

SINGLE ROW
 N:NUMBER OF CONTACTS
 A/B:CUSTOMER LENGTH AVAILABLE

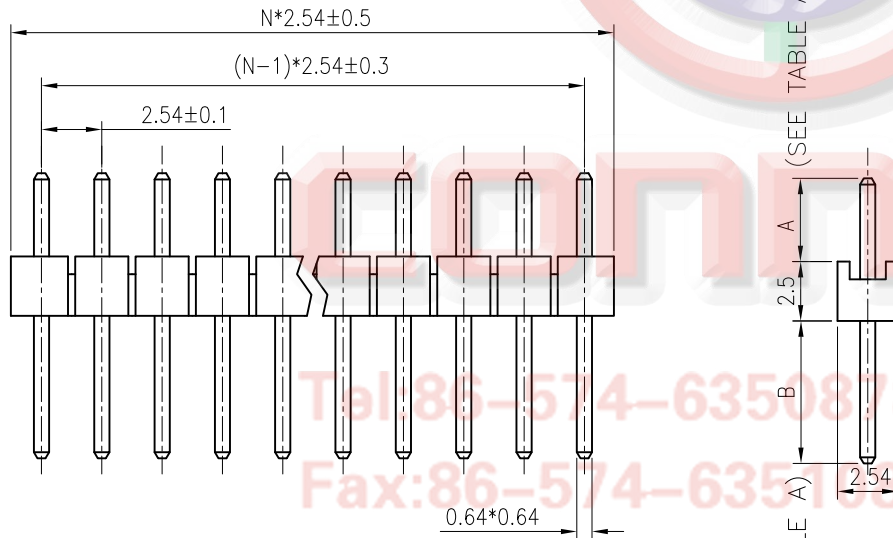

NOTES:

1. ELECTRICAL CHARACTERISTICS:

- 1.1 CONTACT RESISTANCE: 20mΩ Max.
- 1.2 DIELECTRIC WITHSTANDING VOLTAGE: 500V AC(rms) FOR 1 MINUTE.
- 1.3 INSULATION RESISTANCE: 1000MΩ Min.

2. ENVIRONMENT CHARACTERISTICS:

- 2.1 TEMPERATURE: -40°C~+105°C.

3. PRODUCT NUMBER CODE:

DS1021- X X X X - X

PLATING LEVEL(FOR GOLD ONLY)
 3A: LEVEL 3A B: LEVEL B
 N: LEVEL N

TABLE A & DIM. TYPE

- 1: TYPE 1
- 2: TYPE 2
- 3: TYPE 3
- 4: TYPE 4
- 5: TYPE 5
- 6: TYPE 6
- 7: TYPE 7
- 8: TYPE 8
- 9: TYPE 9

CONTACT PLATING
 F1: FULL GOLD FLASH
 6: FULL TIN

MOUNTING TYPE
 S: STRAIGHT TYPE

No. OF CONTACTS
 1*1~1*40

Tel:86-574-63508787
 Fax:86-574-63515317
 E-mail:sale@connfly.com
 http://www.connfly.com
 Add:East Industry Zone KuangYan
 Town Cixi Ningbo China
 P.C:315333

GENERAL TOLERANCE		ANGLE TOLERANCE		PROJECTION		TITLE	2.54mm PIN HEADER V/T TYPE
X.	±0.60	X.	±5'	UNITS	mm	Single ROW	
.X	±0.38	.X	±3'	SHEET SIZE	A4	SERIES	DS1021 SERIES
.XX	±0.25	.XX	±2'	晨翔电子有限公司 CONNFLY ELECTRONIC CO., LTD			
DRAWING TYPE		CUSTOMER					
SCALE		SHEET 1 OF 2					
DRAWING NO.		C-DS1021-1*XXXX-X					

TABLE A:

TYPE	Dimension	
	A	B
1	3.00	6.10
2	0.00	9.15
3	0.00	12.50
4	0.00	21.50
5	3.00	12.50
6	3.00	3.00
7	3.00	17.30
8	2.50	5.80
9	3.00	7.10
10	3.00	8.30
11	3.00	9.30
12	3.00	12.30
13	0.40	7.30
14	3.00	14.50
15	3.00	5.30
16	3.00	3.50
17	0.00	9.00
18	6.00	11.50
19	3.00	18.80
20	3.00	10.50
21	6.25	6.25
22	3.00	12.10
23	3.00	11.50
24	3.00	13.50
25	3.00	8.50
26	3.00	15.50
27	3.00	17.50
28	3.00	20.50
29	3.00	8.90

TABLE A:

TYPE	Dimension	
	A	B
30	3.20	19.40
31	5.00	12.50
32	3.00	9.50
33	3.00	19.50
34	3.00	29.50
35	3.00	6.96
36	3.00	5.96
37	3.00	5.50
38	3.00	14.30
39	3.00	15.90
40	3.00	21.50
41	3.34	13.96
42	3.50	22.00
43	3.00	24.50
44	3.00	34.50
45	3.00	18.50
46	3.00	8.00
47	6.00	6.00
48	3.00	7.50
49	3.00	5.00
50	3.00	9.00
51	3.00	11.00
52	3.20	14.20
53	3.00	23.50
54	3.00	9.46
55	3.00	16.50
56	0.60	8.50
57	3.00	28.50
58	3.30	15.60

TABLE A:

TYPE	Dimension	
	A	B
59	3.00	30.50
60	4.00	4.00
61	2.00	4.00
62	3.00	6.50
63	3.00	10.00
64	2.00	4.50
65	1.00	4.50
66	4.00	6.00
67	3.00	4.00
68	4.50	7.00
69	3.00	15.00
70	4.50	4.50
71	2.50	25.00
72	3.50	24.00
73	3.00	4.50
74	3.50	17.00
75	3.50	13.00
76	3.50	9.00
77	3.50	6.10
78	3.10	15.40
79	5.50	9.00
80	5.50	13.00
81	3.50	5.60
82	8.60	8.60
83	3.30	6.80
84	3.10	6.00
85	2.50	3.50
86	3.00	22.50
87	3.00	12.00

TABLE A:

TYPE	Dimension	
	A	B
88	4.20	7.80
89	1.60	5.80
90	5.00	12.00
91	4.20	4.20
92	1.20	12.30
93	5.33	5.84
94	5.84	15.49
95	1.50	5.80
96	3.50	3.50
97	3.00	26.50
98	0.00	6.00
99	3.00	20.00
100	5.33	5.84
101	2.85	4.15
102	8.00	2.70
103	3.00	25.00

TABLE A:

TYPE	Dimension	
	A	B

TABLE A:

TYPE	Dimension	
	A	B

P.C:315333

GENERAL TOLERANCE	ANGLE TOLERANCE	PROJECTION		TITLE	2.54mm PIN HEADER V/T TYPE Single ROW
X. ±0.60 .X ±0.38 .XX ±0.25	X. ±5' .X ±3' .XX ±2'	UNITS	mm	SHEET SIZE	A4
DRAWING TYPE	CUSTOMER	SHEET	2 OF 2	SERIES	DS1021 SERIES
SCALE	~	DRAWING NO.	C-DS1021-1*XXX-X	晨翔电子有限公司 CONNFLY CONNFLY ELECTRONIC CO., LTD	

REV.	DESCRIPTION	DRAWN	CHECKED	APPROVED
A	NEW RELEASE	LL 07/03/06'	~	LJC 04/04/06'
F	ADD DIM	LL 11/05/06'	~	LJC 11/05/06'
H	ADD DIM	LL 11/16/06'	~	LJC 11/16/06'
J	ADD DIM	YCH 09/12/07'	~	LJC 09/12/07'
K	ADD DIM	LBG 01/27/10'	~	LJC 01/27/10'
M	ADD P/N CODE	LJC 12/08/13'		

NOTES:

- ELECTRICAL CHARACTERISTICS:
 - CONTACT RESISTANCE: 20mΩ Max.
 - DIELECTRIC WITHSTANDING VOLTAGE: 500V AC(rms) FOR 1 MINUTE.
 - INSULATION RESISTANCE: 1000MΩ Min.

- ENVIRONMENT CHARACTERISTICS:
 - TEMPERATURE: -40°C~+105°C.

3. PRODUCT NUMBER CODE:

DS1021- X X X X - X

PLATING LEVEL(FOR GOLD ONLY)
 3A: LEVEL 3A B: LEVEL B
 N: LEVEL N

TABLE A & DIM. TYPE

- 1: TYPE 1
- 2: TYPE 2
- 3: TYPE 3
- 4: TYPE 4
- 5: TYPE 5
- 6: TYPE 6
- 7: TYPE 7
- 8: TYPE 8
- 9: TYPE 9

CONTACT PLATING
 F1: FULL GOLD FLASH
 6: FULL TIN

MOUNTING TYPE
 S: STRAIGHT TYPE
 No. OF CONTACTS
 2*1~2*40

DUAL ROWS
 N:NUMBER OF CONTACTS/2
 C/D:CUSTOMER LENGTH AVAILABLE

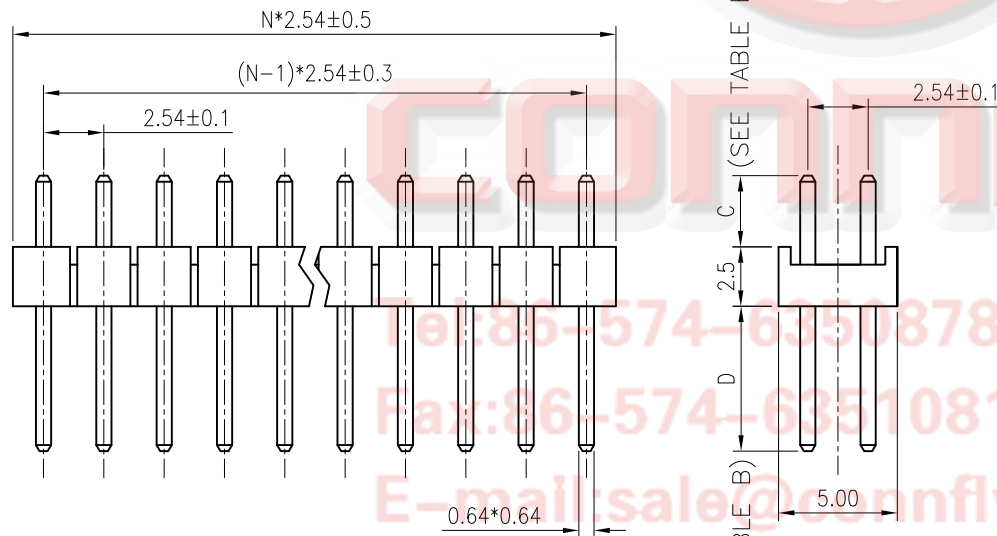

CONNFLY

Tel: 86-574-63508787
 Fax: 86-574-63510817
 E-mail: sale@connfly.com
 http://www.connfly.com
 Add: East Industry Zone KuangYan
 Town Cixi Ningbo China
 P.C: 315333

GENERAL TOLERANCE		ANGLE TOLERANCE		PROJECTION		TITLE	2.54mm PIN HEADER V/T TYPE
X.	±0.60	X.	±5'	UNITS	mm	2 ROWS	
.X	±0.38	.X	±3'	SHEET SIZE	A4	SERIES	DS1021 SERIES
.XX	±0.25	.XX	±2'	晨翔电子有限公司 CONNFLY CONNFLY ELECTRONIC CO., LTD			
DRAWING TYPE		CUSTOMER					
SCALE		SHEET 1 OF 2					
DRAWING NO.		C-DS1021-2*XXXX-X					

THREE ROWS
 N:NUMBER OF CONTACTS/3
 E/F:CUSTOMER LENGTH AVAILABLE

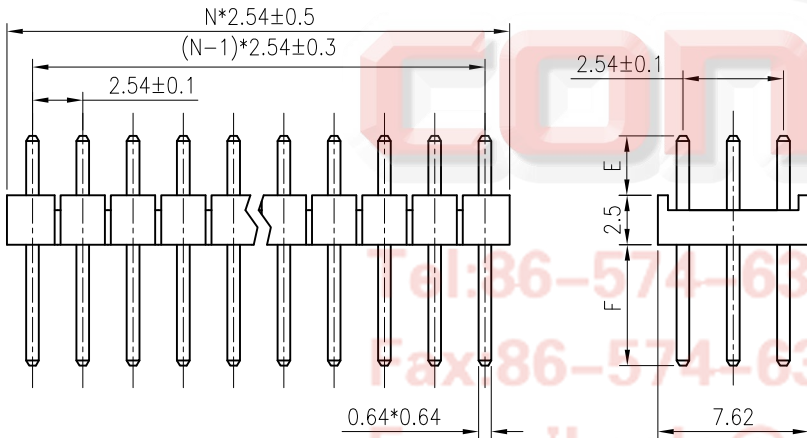

TABLE B:

TYPE	Dimension	
	E	F
1	3.00	6.10
2	7.15	7.15
3		
4		
5		
6		
7		
8		
9		
10		
11		
12		
13		
14		
15		
16		
17		
18		
19		
20		
21		
22		
23		
24		
25		
26		
27		
28		
29		

REV.	DESCRIPTION	DRAWN	CHECKED	APPROVED
A	NEW RELEASE	YCH 07/27/10'	~	

NOTES:

- ELECTRICAL CHARACTERISTICS:
 - CONTACT RESISTANCE: 20mΩ Max.
 - DIELECTRIC WITHSTANDING VOLTAGE: 500V AC(rms) FOR 1 MINUTE.
 - INSULATION RESISTANCE: 1000MΩ Min.

- ENVIRONMENT CHARACTERISTICS:
 - TEMPERATURE: -40°C~+105°C.

3. PRODUCT NUMBER CODE:

DS1021- X X X X - X

PLATING LEVEL(FOR GOLD ONLY)
 3A: LEVEL 3A B: LEVEL B
 N: LEVEL N

TABLE A & DIM. TYPE
 1: TYPE 1
 2: TYPE 2

CONTACT PLATING
 F1: FULL GOLD FLASH
 6: FULL TIN

MOUNTING TYPE
 S: STRAIGHT TYPE

No. OF CONTACTS
 3*1~3*40

Tel: 86-574-63506787
 Fax: 86-574-63513817
 E-mail: sale@connfly.com
 http://www.connfly.com
 Add: East Industry Zone Kuang Yan
 Town Cixi Ningbo China
 P.C: 315333

GENERAL TOLERANCE		ANGLE TOLERANCE		PROJECTION		TITLE	2.54mm PIN HEADER V/T TYPE		
X.	±0.60	X.	±5'	UNITS	mm	3 ROWS			
.X	±0.38	.X	±3'	SHEET SIZE	A4	SERIES	DS1021 SERIES		
.XX	±0.25	.XX	±2'	晨翔电子有限公司 CONNFLY CONNFLY ELECTRONIC CO., LTD					
DRAWING TYPE		CUSTOMER							
SCALE		1:1	SHEET 1 OF 1						
DRAWING NO.		C-DS1021-3*XXXX-X							