



HESTORE.HU

elektronikai alkatrész áruház

EN: This Datasheet is presented by the manufacturer.

Please visit our website for pricing and availability at www.hestore.hu.

SA-15

HALL sensor module

HESTORE Part no.: 1003.5596

Linear magnetic Hall module

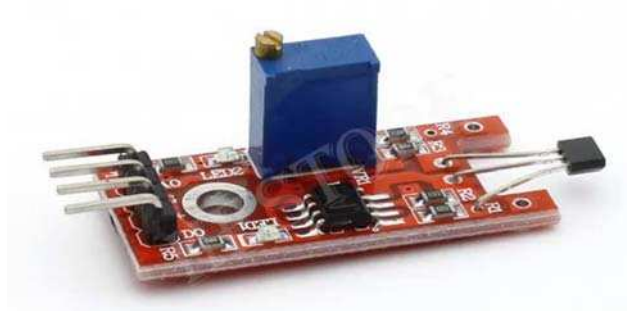

Technical specifications

Operating voltage	3.3-5V DC
Sensitivity	1.0 mV/G min., 1.4 mV/G typ., 1.75 mV/G max.
Compatibility	Arduino, Raspberry Pi, Esp8266 and Teensy
Dimensions	1.5cm x 3.6cm [0.6in x 1.4in]

Description

The SA-15 Linear magnetic Hall sensor reacts in the presence of a magnetic field. It has a potentiometer to adjust the sensitivity of the sensor and it provides both analog and digital outputs.

The digital output (DO) acts as a switch that will turn on/off when a magnet is near. On the other hand, the analog output (AO) can measure the polarity and relative strength of the magnetic field.

Connection with Arduino

SA-15	Arduino
AO	AO
G	GND
+	5V
DO	3

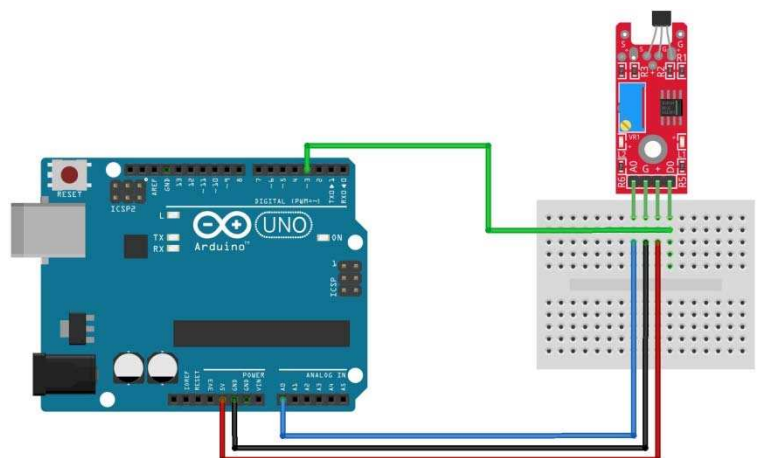

SA-15 example code

The following Arduino sketch will read values from both digital and analog interfaces on the KY-024. The digital interface will turn on the Arduino's LED when a magnetic field is detected.

The analog interface starts at an initial value determined by the input voltage and the potentiometer, this value will increase or decrease depending on the intensity and polarity of the magnetic field.

```
1  int led = 13 ; // LED on arduino
2  int digitalPin = 3; // linear Hall magnetic sensor digital interface
3  int analogPin = A0; // linear Hall magnetic sensor analog interface
4  int digitalVal ; // digital readings
5  int analogVal; // analog readings
6
7  void setup ()
8  {
9      pinMode (led, OUTPUT);
10     pinMode (digitalPin, INPUT);
11     //pinMode(analogPin, INPUT);
12     Serial.begin(9600);
13 }
14
15 void loop ()
16 {
17     // Read the digital interface
18     digitalVal = digitalRead(digitalPin) ;
19     if (digitalVal == HIGH) // When magnetic field is present, Arduino LED is on
20     {
21         digitalWrite (led, HIGH);
22     }
23     else
24     {
25         digitalWrite (led, LOW);
26     }
27
28     // Read the analog interface
29     analogVal = analogRead(analogPin);
30     Serial.println(analogVal); // print analog value
31
32     delay(100);
33 }
```

Setting analog pin as input (line 11) is not necessary, the analogRead() function will automatically set the pin as analog input when used.

Use **Tools > Serial Plotter** on the Arduino IDE to visualize the changes on intensity and polarity of the magnetic field.

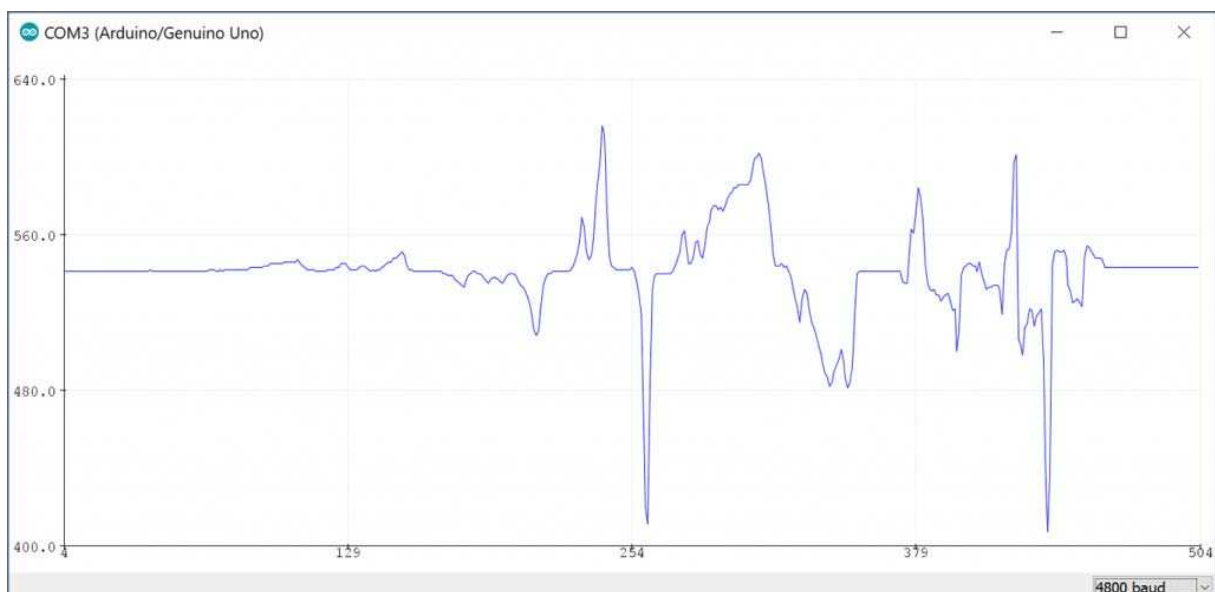

Made in PRC, distributed by HESTORE Hungary Ltd. in EU.

<https://www.hestore.hu/>