



HESTORE.HU

elektronikai alkatrész áruház

EN: This Datasheet is presented by the manufacturer.

Please visit our website for pricing and availability at www.hestore.hu.



8-bit Serial-In/Parallel-Out Constant Current Driver

Product Description

The SCT2168 serial-interfaced LED driver sinks 8 LED clusters with constant current to keep the uniform intensity of LED displays. In applications, an external resistor is used to set the full-scale constant output current from 5mA up to 120mA. The SCT2168 guarantees each output can endure maximum 17V DC voltage stress. The built-in shift registers and data latches making the SCT2168 effective solution in driving LED display. The output enable function gates all 8 outputs on and off, and is fast enough to be used as PWM input for LED intensity control. Since the serial data input rate can be reached up to 25MHz, the SCT2168 will satisfy system which needs high volume data transmission to control the LED display.

Features

- ◆ 8 constant current sinker with LED power-supply voltage up to 17V
- ◆ Constant output current : 5 – 120mA@5V, 3 – 80mA@3.3V
- ◆ Excellent current regulation to load, supply voltage and temperature
- ◆ ±1% Current matching between outputs
- ◆ ±3% Current matching between ICs
- ◆ Fast output current control: Minimum PWM pulse width = 120ns
- ◆ All output current are programmed together using a single external resistor
- ◆ CMOS Schmitt trigger inputs with clock rate up to 25MHz
- ◆ Operating supply voltage range of 3.3V to 5.5V
- ◆ Built-in power on reset circuit forces all the outputs off while power on
- ◆ Built-in thermal protection function to prevent damage from over current operation
- ◆ Gradually 2ns delayed outputs to lower output switching noise
- ◆ Package: SOP16, SSOP16,SOP16W
- ◆ Applications: LED Displays, Variable Message Signs, LED Traffic Signs

Selector Guide

Part	Number of Outputs	Max Output Current (mA)	Min PWM Pulse Width (ns)	Supply Voltage (V)
SCT2110	8	180	100	5
SCT2167	8	60	180	3.3/5
SCT2168	8	120	120	3.3/5
SCT2210	16	120	50	5
SCT2026	16	90	120	5
SCT2024	16	60	180	3.3/5

StarChips Technology, Inc.

4F, No.5, Technology Rd., Science-Based Industrial Park, Hsin-Chu, Taiwan, R.O.C

TEL: +886-3-577-5767 # 555 FAX: +886-3-577-6575 E-mail: service@starchips.com.tw

Block Diagram

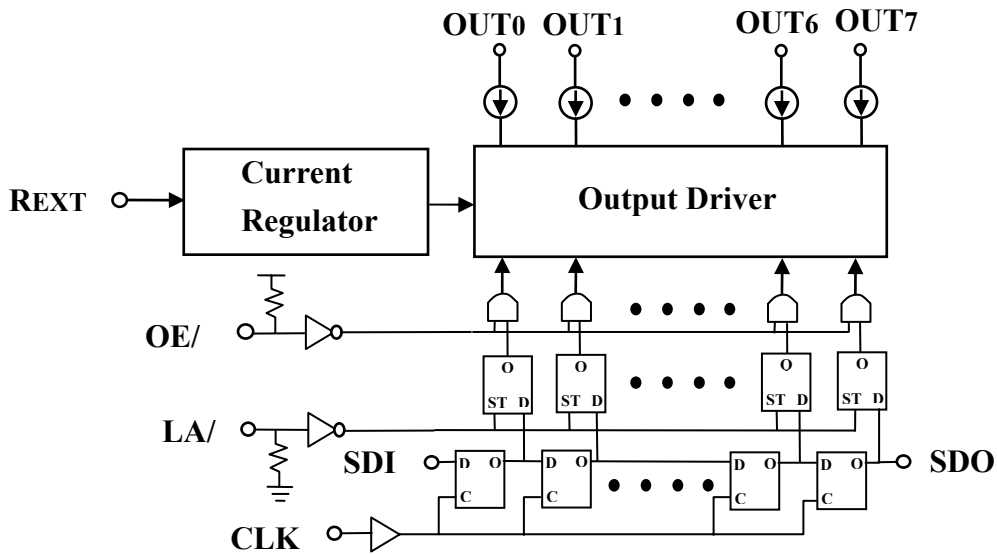

Pin Configuration

Ordering information

GND	1	●	16	VDD
SDI	2		15	REXT
CLK	3	SCT2168	14	SDO
LA/	4	C SOG	13	OE/
OUT0	5	C SS G	12	OUT7
OUT1	6	C SW G	11	OUT6
OUT2	7		10	OUT5
OUT3	8		9	OUT4

Part Number	Package
SCT2168CSOG	Green SOP16
SCT2168CSSG	Green SSOP16
SCT2168CSWG	Green SOP16W

Terminal Description

Pin No.	Pin Name	Function
1	GND	Ground terminal.
2	SDI	Serial input terminal of data shift register.
3	CLK	Clock input terminal of shift register, data is sampled at the rising edge of CLK.
4	LA/	Data is latched when LA/ is low. Data on shift register goes through when LA/ is high.
5 ~ 12	OUT0 ~ OUT7	Output terminals with constant current.
13	OE/	Input terminal of output enable signal. Output is enabled when OE/ is low.
14	SDO	Output terminal of serial-data output to the SDI of next SCT2168.
15	REXT	Input terminal used to connect an external resistor for setting up all output current.
16	VDD	Supply voltage terminal.

Truth Table

CLK	LA/	OE/	SDI	OUT0 ~ OUT7	SDO
↑	H	L	Dn	Dn Dn-1 ---- Dn-6 Dn-7	Dn-7
↑	L	L	Dn+1	No change	Dn-6
↑	H	L	Dn+2	Dn+2 Dn+1 ---- Dn-6 Dn-5	Dn-5
↓	X	L	Dn+3	Dn+2 Dn+1 ---- Dn-6 Dn-5	Dn-5
↓	X	H	Dn+3	Off	Dn-5

Timing Diagram

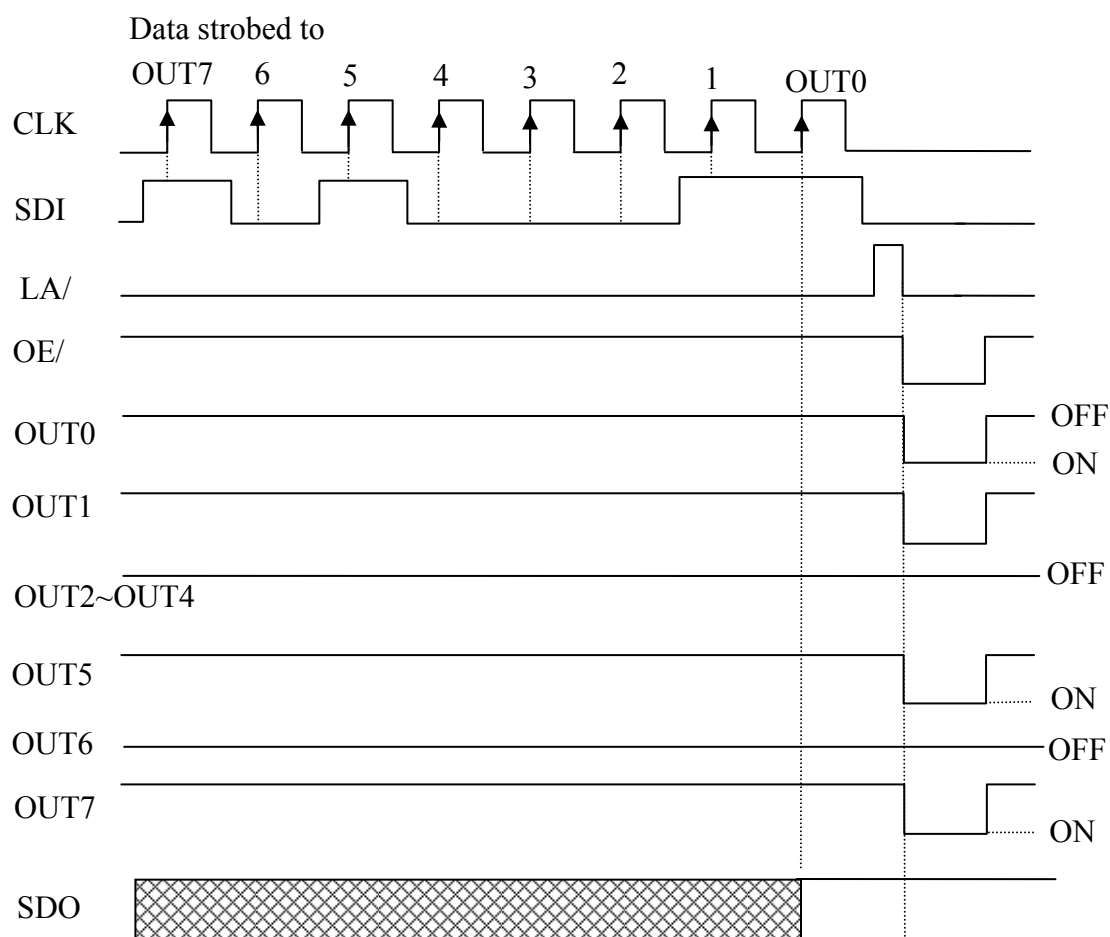

Equivalent Circuits of Inputs (1)

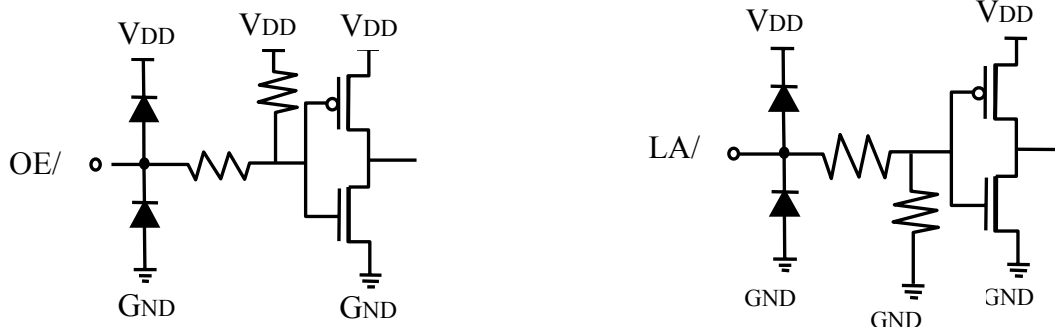

Equivalent Circuits of Inputs (2)

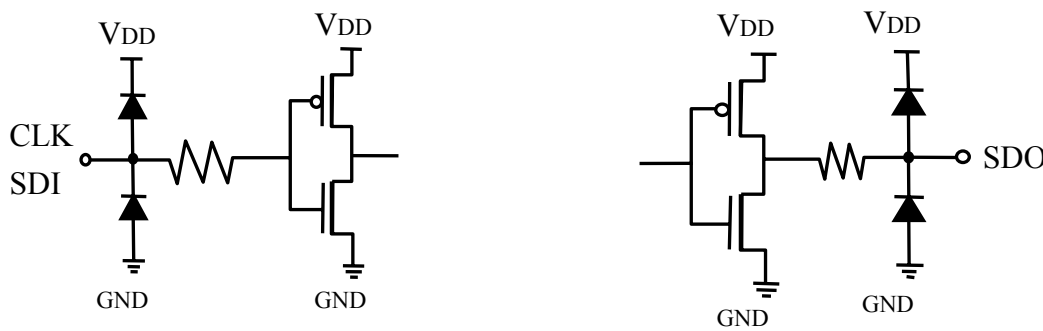

Maximum Ratings (Ta = 25 °C)

Characteristic	Symbol	Rating	Unit
Supply voltage	V _{DD}	7.0	V
Input voltage	V _{IN}	-0.2 ~ V _{DD} +0.2	V
Output current	I _{OUT}	120	mA/Channel
Output voltage	V _{OUT}	-0.2 ~ 17.0	V
Total GND terminals current	I _{GND}	960	mA
Power Dissipation(on PCB)	P _{DI}	1.47	W
	P _{DII}	1.79	
	P _{DIII}	1.07	
Thermal Resistance(on PCB)	R _{TH(j-a)I}	85	°C /W
	R _{TH(j-a)II}	70	
	R _{TH(j-a)III}	117	
Operating temperature	T _{OPR}	-40~+85	°C
Storage temperature	T _{STG}	-55~+150	°C

● Type I : SOP16, II : SOP16W, III : SSOP16

Recommended Operating Conditions ($T_a = -40$ to 85 °C unless otherwise noted)

Characteristic	Symbol	Condition	Min.	Typ.	Max.	Unit
Supply voltage	V_{DD}	-	3	-	5.5	V
Output voltage	V_{OUT}	Output OFF	-	-	17	V
Output voltage	V_{OUT}	Output ON	1	-	4	V
Output current	I_{OUT}	$V_{DD} = 3.3/5V$	5	-	60/90	mA
Input voltage	V_{IH}	Input signals	$0.7V_{DD}$	-	V_{DD}	V
	V_{IL}	Input signals	0	-	$0.3V_{DD}$	V
OE/ pulse width	t_w	$V_{DD} = 3.3/5V$	120	-	-	ns

Electrical Characteristics ($V_{DD} = 3.3/5V$, $T_a = 25$ °C unless otherwise noted)

Characteristic	Symbol	Condition	Min.	Typ	Max.	Unit	
Input voltage	V_{IH}	-	$0.7V_{DD}$	-	V_{DD}	V	
	V_{IL}	-	0	-	$0.3V_{DD}$	V	
SDO Output Voltage	V_{OH}	$V_{DD} = 3.3/5V$, $I_{OH} = -1mA$	3.0/4.5	-	-	V	
	V_{OL}	$V_{DD} = 3.3/5V$, $I_{OL} = +1mA$	-	-	0.4	V	
Output leakage current	I_{OL}	$V_{OUT} = 17V$	-	-	0.5	μA	
Output current	I_{OUT}	$V_{OUT} = 1.0V$, $R_{EXT} = 900\Omega$	-	42	-	mA	
Current bit skew	dI_{OUT}	$I_{OUT} = 42mA$, $V_{OUT} = 1.0V$, $R_{EXT} = 900\Omega$	-	± 1	± 2	%	
Output current	I_{OUT}	$V_{OUT} = 1.0V$, $R_{EXT} = 1860\Omega$	-	20	-	mA	
Current bit skew	dI_{OUT}	$I_{OUT} = 20mA$, $V_{OUT} = 1.0V$, $R_{EXT} = 1860\Omega$	-	± 1	± 2	%	
I_{OUT} vs. supply voltage regulation	$\%/dV_{DD}$	$3V < V_{DD} < 5.5V$, $V_{OUT} > 1.0V$, $R_{EXT} = 900\Omega$	-	-	± 1	%/V	
I_{OUT} vs. output voltage regulation	$\%/dV_{OUT}$	$1V < V_{OUT} < 4V$, $I_{OUT} = 42mA$, $R_{EXT} = 900\Omega$	-	± 0.1	± 0.5	%/V	
Pull-up resistor	$R_{in(up)}$	OE/	-	500	-	K Ω	
Pull-down resistor	$R_{in(down)}$	LA/	-	500	-	K Ω	
Thermal Shutdown	T_H	Junction Temp.	-	160	-	$^{\circ}C$	
	T_L		-	110	-	$^{\circ}C$	
Supply current	OFF	$I_{DD(off)1}$	$R_{EXT} = \text{Open}$, $V_{DD} = 3.3/5V$, $OUT_0 \sim OUT_7 = \text{Off}$	-	2	3	mA
		$I_{DD(off)2}$	$R_{EXT} = 900\Omega$, $V_{DD} = 3.3/5V$, $OUT_0 \sim OUT_7 = \text{Off}$	-	5	7	
	ON	$I_{DD(on)}$	$R_{EXT} = 900\Omega$, $V_{DD} = 3.3/5V$, $OUT_0 \sim OUT_7 = \text{On}$	-	8	10	

Switching Characteristics (Ta=25°C unless otherwise noted)

Characteristic		Symbol	Condition	Min.	Typ.	Max.	Unit
Propagation Delay Time ("L" to "H")	CLK - OUTn	t _{pLH1}	V _{DD} = 3.3/5V V _{LED} = 5V V _{IH} = V _{DD} V _{IL} = GND R _{EXT} = 1860 Ω R _L = 180 Ω C _L = 10 pF	-	80	100	ns
	LA/ - OUTn	t _{pLH2}		-	80	100	ns
	OE/ - OUTn	t _{pLH3}		-	80	100	ns
	CLK - SDO	t _{pLH}		-	20	40	ns
Propagation Delay Time ("H" to "L")	CLK - OUTn	t _{pHL1}		-	80	100	ns
	LA/ - OUTn	t _{pHL2}		-	80	100	ns
	OE/ - OUTn	t _{pHL3}		-	80	100	ns
	CLK - SDO	t _{pHL}		-	20	40	ns
Pulse Width	CLK	t _{w(CLK)}		20	-	-	ns
	LA/	t _{w(L)}		20	-	-	ns
	OE/	t _{w(OE/)}		120	-	-	ns
Hold Time for LA/		t _{h(L)}		5	-	-	ns
Setup Time for LA/		t _{s(L)}	5	-	-	ns	
Output Rise Time of Iout		t _{oR}	-	80	100	ns	
Output Fall Time of Iout		t _{oF}	-	80	100	ns	
Output Delay		t _{dR}	OUT _{n+1} - OUT _n	-	2	-	ns
		t _{dF}		-	2	-	ns
Slow CLK rise time		t _R	Cascade	-	-	500	ns
Slow CLK fall time		t _F		-	-	500	ns

Test Circuit for Switching Characteristics

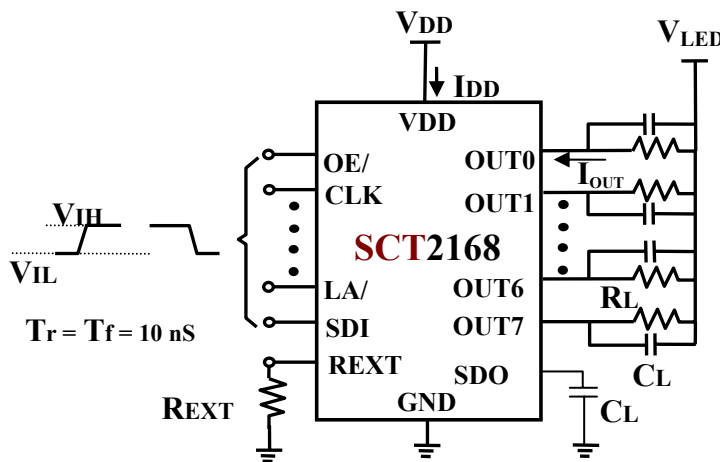

Timing Waveform

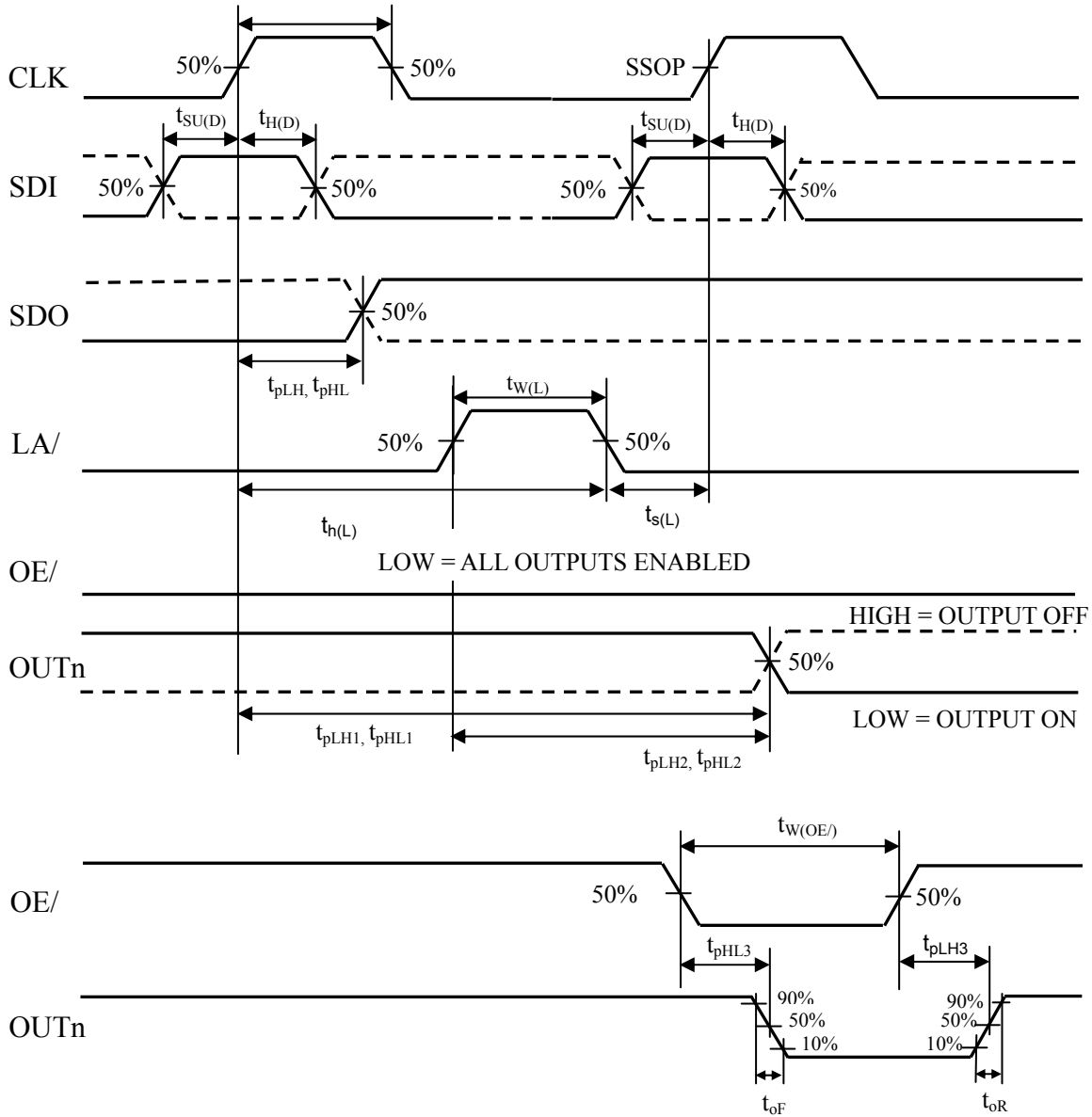

Adjusting Output Current

All SCT2168's output current (I_{OUT}) are set by one external resistor at pin R_{EXT} . The relationship between I_{OUT} and resistance R_{EXT} is shown as the following figure.

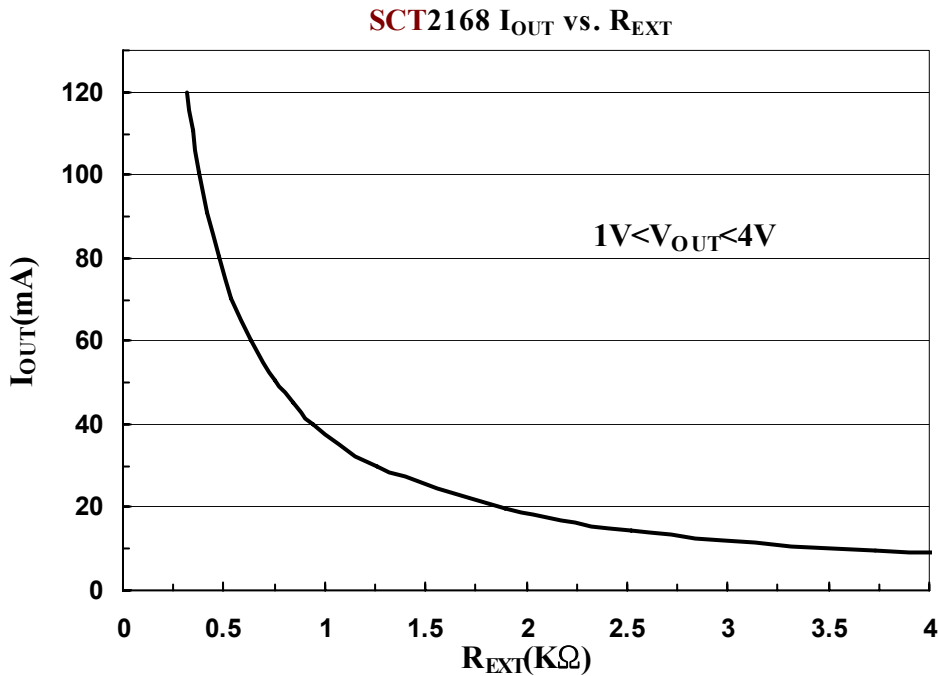

Also, when SCT2168's output voltage is set between 1 Volt and 4 Volt, the output current can be estimated approximately by: $I_{OUT} = 60(620 / R_{EXT})$ (mA)(chip skew ± 5). Thus the output current are all set to be about 42mA at $R_{EXT} = 900\Omega$.

Load Supply Voltage (V_{LED})

The SCT2168 can operate very well when V_{OUT} ranging from 1V to 4V. So it is recommended to use the lowest possible supply voltage or set a voltage reducer to reduce the V_{OUT} voltage. A voltage reducer lets $V_{OUT} = V_{LED} - V_{DROP} - V_F$. Resistors or Zener diode can be used in the applications as shown in the following figures.

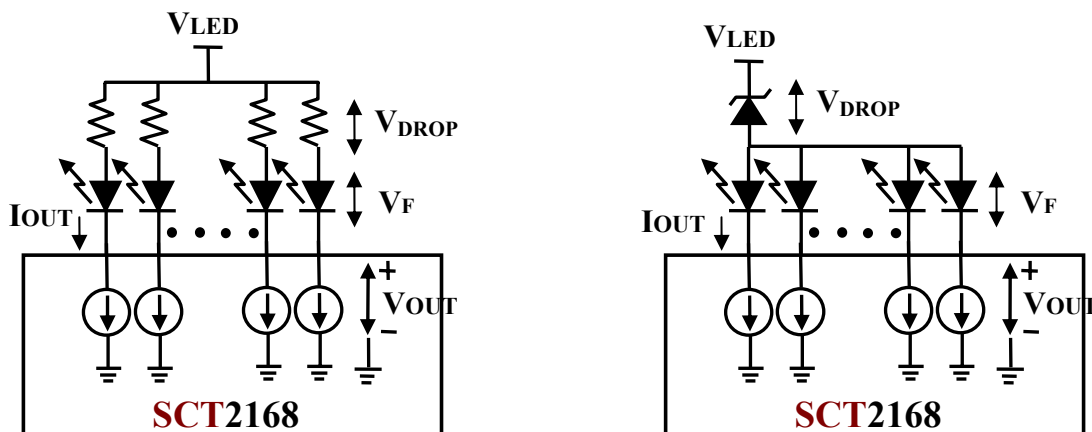

Constant Current

The current characteristic of output stage is flat. The output current can be kept constant regardless of the variations of LED forward voltage when $V_{OUT} > 1.0V$.

The relationship between I_{OUT} and V_{OUT} is shown as below:

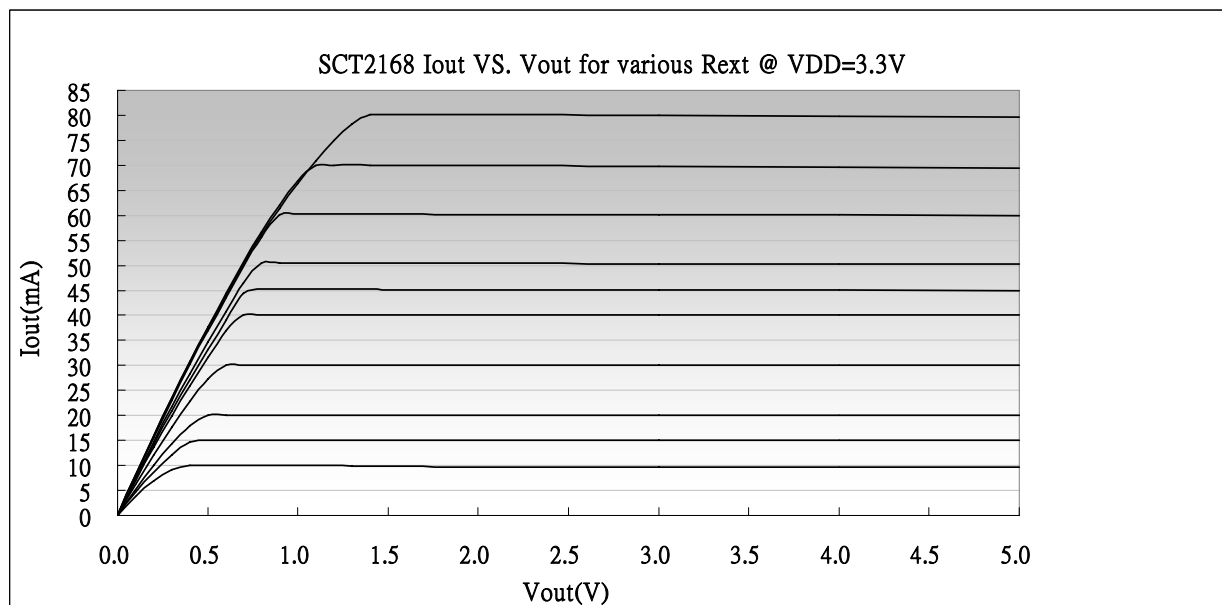
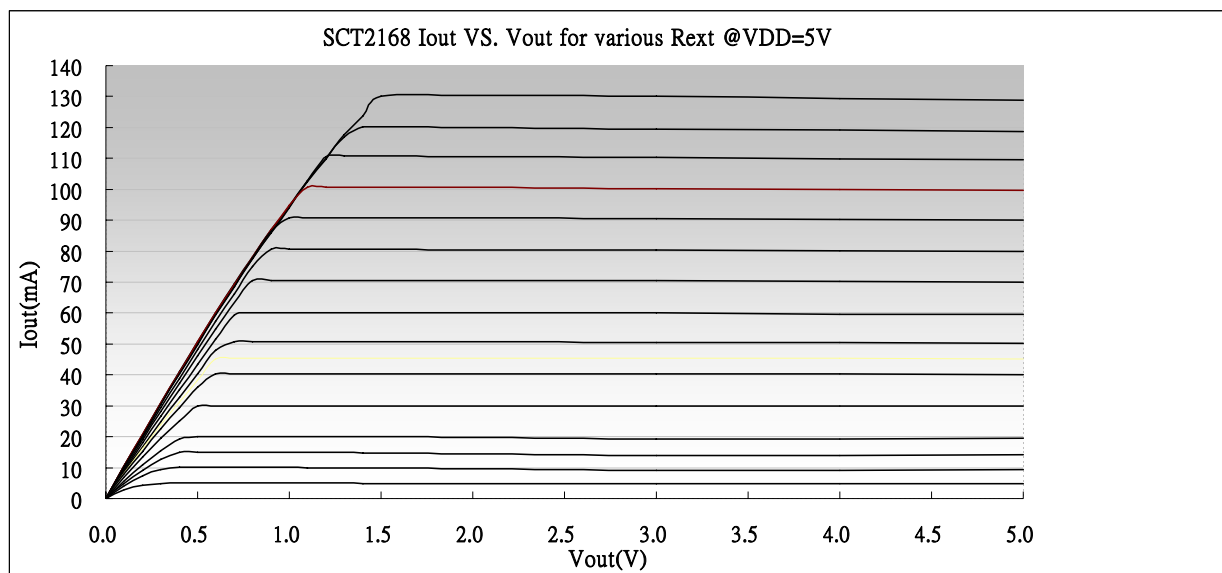

Power Dissipation

The power dissipation (P_D) of a semiconductor chip is limited by its package and ambient temperature. The maximum allowable power dissipation $P_{D(max)}$ is determined by $P_{D(max)} = (T_{j(max)} - T_a) / R_{th(j-a)}$ where $T_{j(max)}$: maximum chip junction temperature, usually considered as 150°C , T_a : ambient temperature, $R_{th(j-a)}$: thermal resistance of the package. The relationship between $P_{D(max)}$ and T_a is shown as the below figure:

SCT2168 Max. Power Dissipation at Various Ambient Temperature

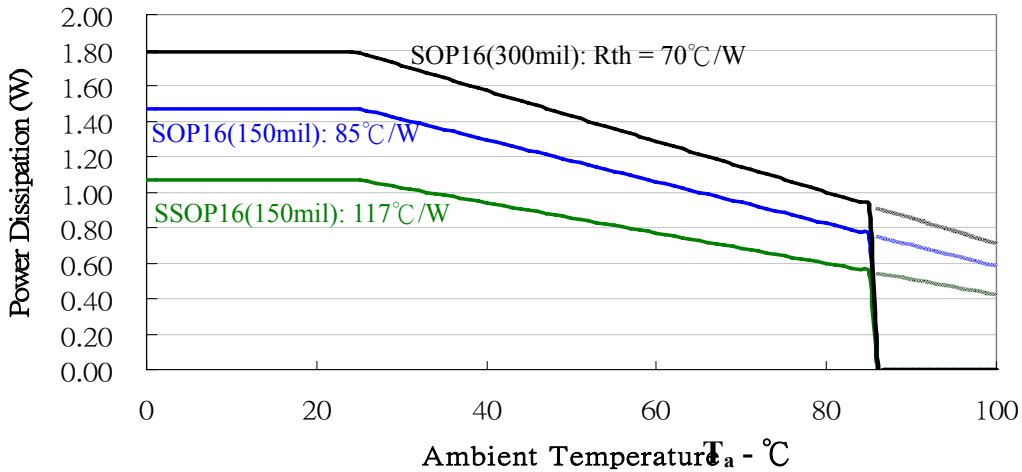

Limitation on Maximum Output Current

The maximum output current vs. duty cycle is estimated by:

$$I_{OUT(max)} = \frac{((T_{j(max)} - T_a) / R_{th(j-a)}) - (V_{DD} * I_{DD})}{V_{OUT} / \text{Duty} / N}$$

Where $T_{j(max)} = 150^\circ\text{C}$, $N = 8$ (all ON)

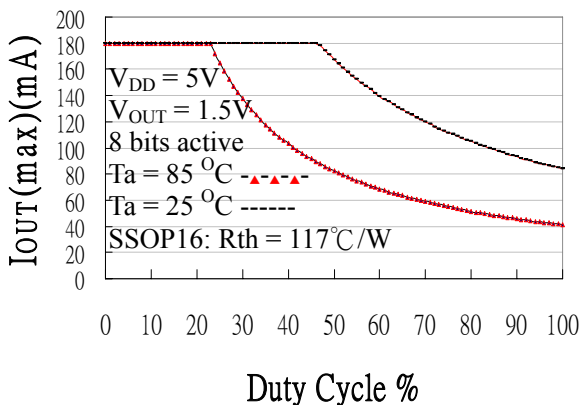
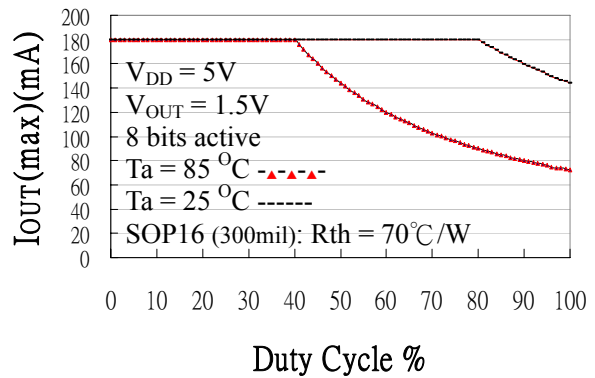
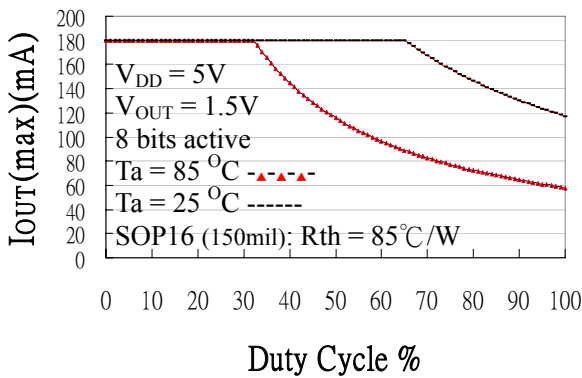

Over Temperature Shutdown

The SCT2168 contains thermal shutdown scheme to prevent damage from over heat. The internal thermal sensor turns off all outputs when the die temperature exceeds approximately +160°C. The outputs are enabled again when the die temperature drops below approximately +110°C.

Typical Application Circuits

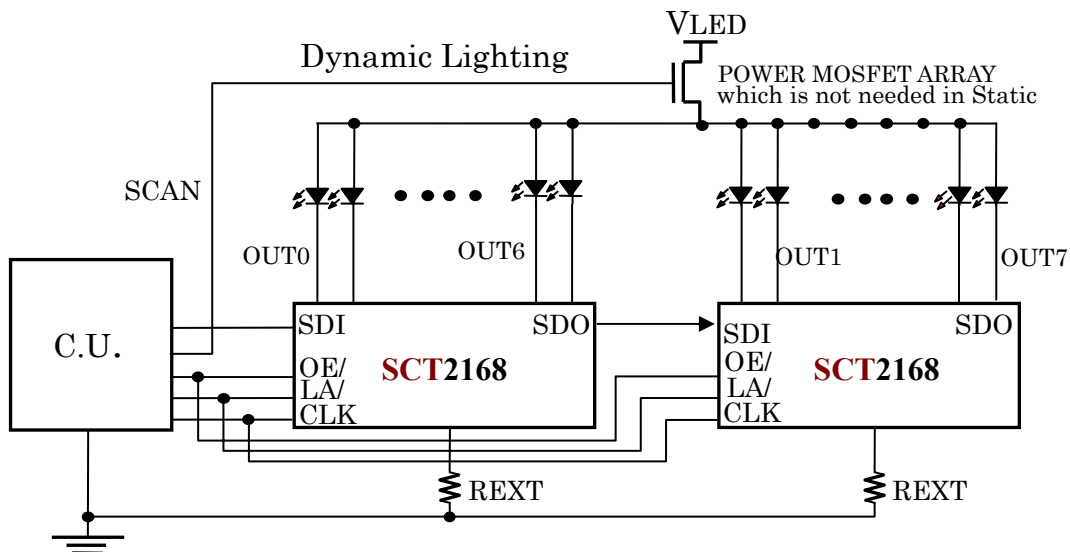

PCB Design Considerations

Use the following general guide-lines when designing printed circuit boards (PCB):

Decoupling Capacitor

Place a decoupling capacitor e.g. 0.1uF between VDD and GND pins of SCT2168. Locate the capacitor as close to the SCT2168 as possible. This is normally adequate for static LED driving. For dynamic scan or PWM applications, it is necessary to add an additional capacitor of 4.7uF or more to each supply for every SCT2168. The necessary capacitance depends on the LED load current, PWM switching frequency, and serial-in data speed. Inadequate VDD decoupling can cause timing problems, and very noisy LED supplies can affect LED current regulation.

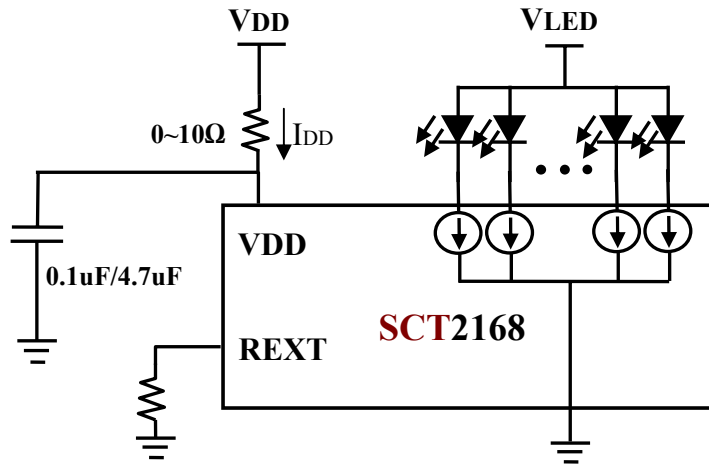

External Resistor (REXT)

Locate the external resistor as close to the REXT pin as possible to avoid the noise influence.

Power and Ground

Maximizing the width and minimizing the length of VDD and GND trace improve efficiency and ground bouncing by effect of reducing both power and ground parasitic resistance and inductance. A small value of resistor e.g. less than 10Ω series in power input pin VDD of SCT2168 in conjunction with decoupling capacitor shunting the ICs is recommended. Separating and feeding the LED power from another supply terminal VLED is strongly recommended as well to get stable supply voltage at pins of VDD.

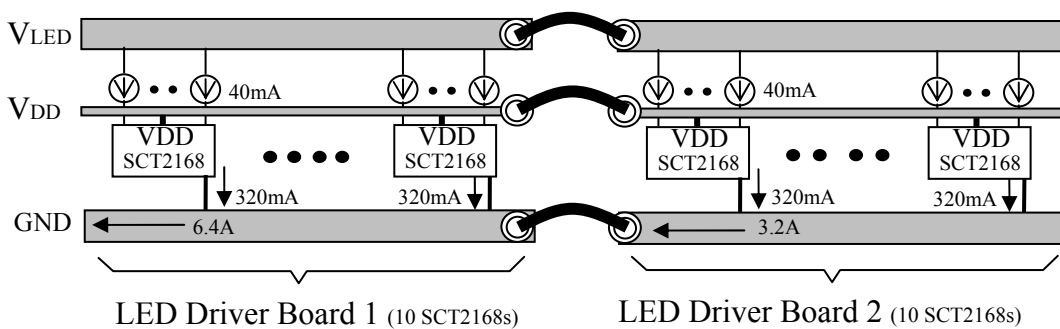

Package Dimension

SOP16([check up-to-date version](#))

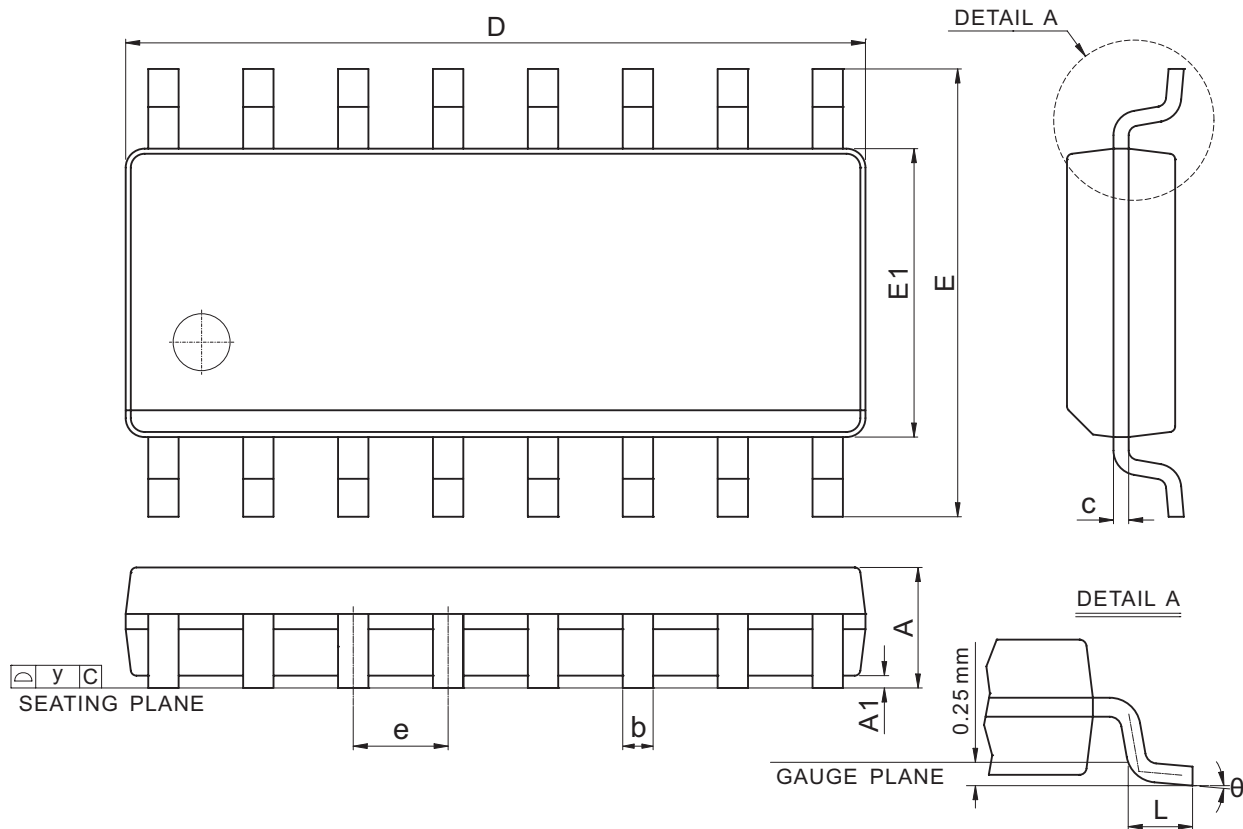

Symbol	Dimension (mm)			Dimension (mil)		
	Min.	Nom.	Max.	Min.	Nom.	Max.
A	1.35	-	1.75	53.1	-	68.9
A1	0.10	-	0.25	3.9	-	9.8
b	0.33	-	0.51	13.0	-	20.1
c	0.19	-	0.25	7.5	-	9.8
D	9.80	-	10.00	385.8	-	393.7
E	5.80	-	6.20	228.3	-	244.1
E1	3.80	-	4.00	149.6	-	157.5
e	1.27 BSC			50.0 BSC		
L	0.40	-	1.27	15.7	-	50.0
θ	0°	-	8°	0°	-	8°
y	-	-	0.10	-	-	3.9

SOP16W([check up-to-date version](#))

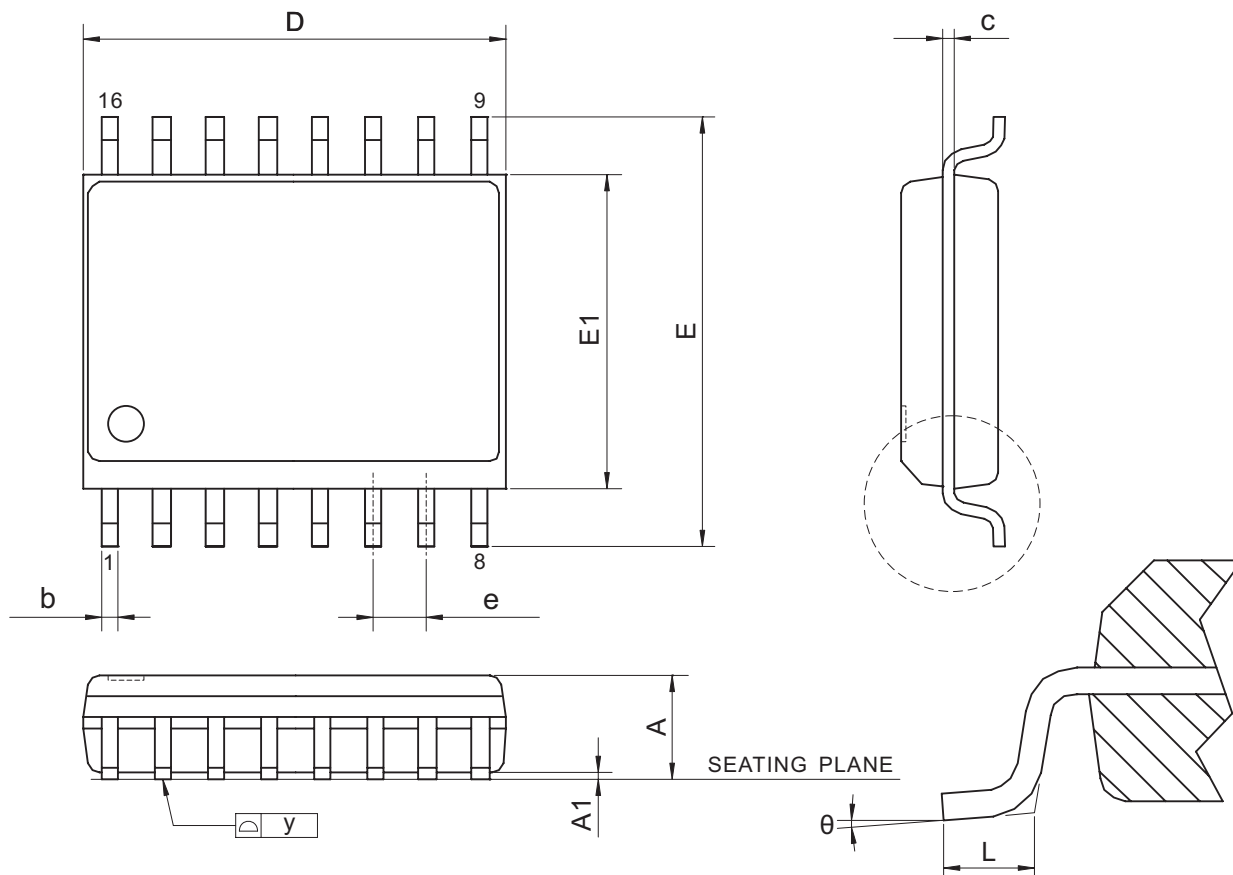

Symbol	Dimension (mm)			Dimension (mil)		
	Min.	Nom.	Max.	Min.	Nom.	Max.
A	2.36	-	2.64	93.0	-	104.0
A1	0.10	-	0.30	4.0	-	12.0
b	-	0.41	-	-	16.0	-
c	-	0.2	-	-	8.0	-
D	10.12	-	10.49	398.0	-	413.0
E	10.01	-	10.64	394.0	-	419.0
E1	7.39	-	7.59	291.0	-	299.0
e	-	1.27	-	-	50.0	-
L	0.41	-	1.27	16.0	-	50.0
θ	0°	-	8°	0°	-	8°
y	-	-	0.10	-	-	4.0

SSOP16([check up-to-date version](#))

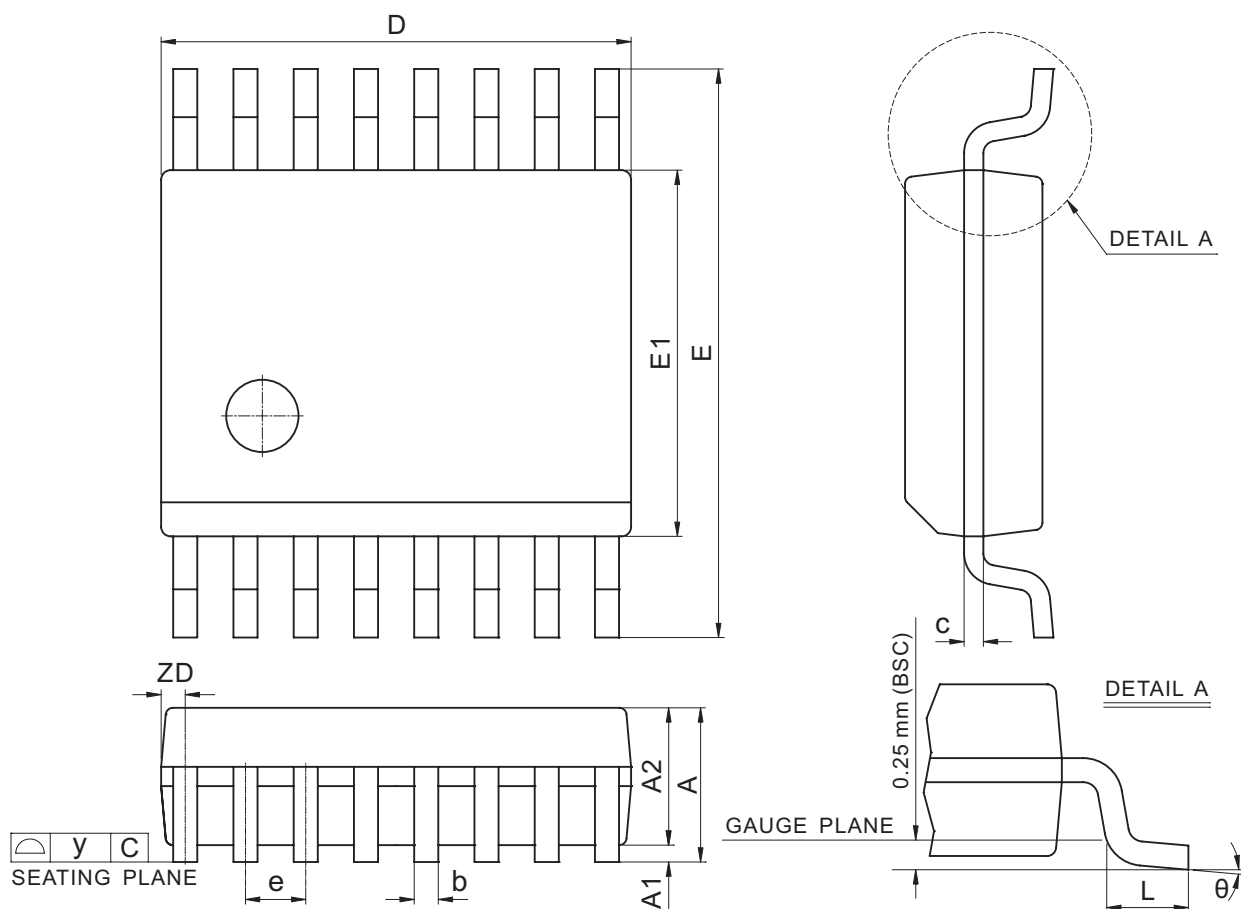

Symbol	Dimension (mm)			Dimension (mil)		
	Min.	Nom.	Max.	Min.	Nom.	Max.
A	1.35	1.63	1.75	53.1	64.2	68.9
A1	0.10	0.15	0.25	3.9	5.9	9.8
A2	-	-	1.50	-	-	59.1
b	0.20	-	0.30	7.9	-	11.8
c	0.18	-	0.25	7.1	-	9.8
D	4.80	4.90	5.00	189.0	192.9	196.9
E	5.79	5.99	6.20	228.0	235.8	244.1
E1	3.81	3.91	3.99	150.0	153.9	157.1
e	0.64 BSC			25.0 BSC		
L	0.41	0.64	1.27	16.1	25.0	50.0
y	-	-	0.10	-	-	3.9
ZD	0.23 REF			9.0 REF		
θ	0°	-	8°	0°	-	8°

Revision History ([check up-to-date version](#))

Data Sheet Version	Remark
V01_01	New Release

Information provided by StarChips Technology is believed to be accurate and reliable. Application circuits shown, if any, are typical examples illustrating the operation of the devices. StarChips can not assume responsibility and any problem raising out of the use of the circuits. StarChips reserves the right to change product specification without prior notice.