



HESTORE.HU

elektronikai alkatrész áruház

EN: This Datasheet is presented by the manufacturer.

Please visit our website for pricing and availability at www.hestore.hu.

Top View of Assembly

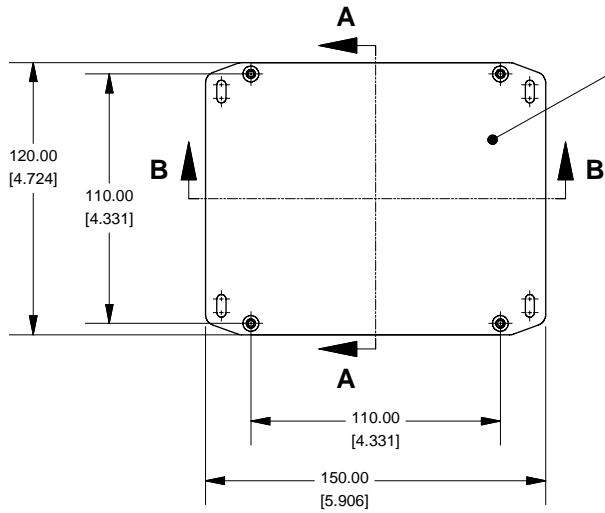

SECTION A-A End View of Assembly

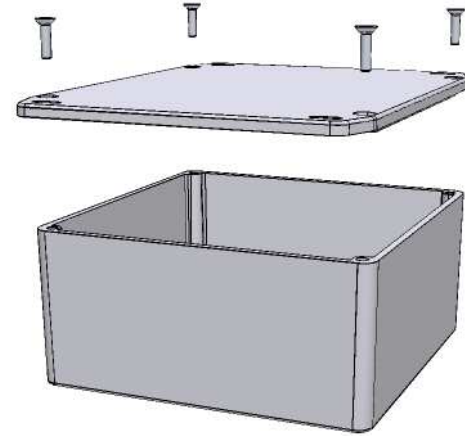
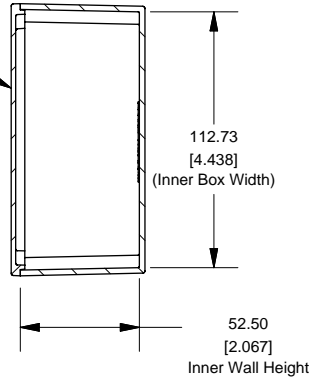

SECTION B-B Side View of Assembly

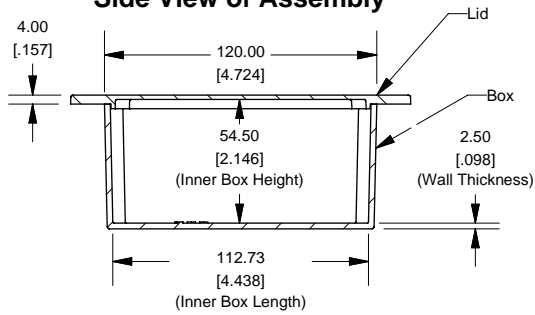

Top View Looking Inside Box

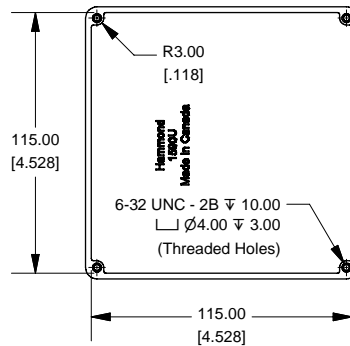

Enclosures can be Factory Modified (Milling, Drilling, Printing etc.)
 Contact Factory mjm@hammondmfg.com for quotes
 Solid models of this enclosure available in STEP or IGES.

NOTE	
Purchased assembly includes box, lid and 4 cover screws.	
Box and lid are made from Diecast Aluminum Alloy (alloy type 380).	
Silicone Gasket Loctite #5950	

PART NUMBERS	
1590UFL Enclosure	
Unfinished	1590UFL
Grey Textured Polyester Powder Paint - RAL 7038	1590UFLGY
Black Textured Polyester Powder Paint - RAL 9011	1590UFLBK
1590UFL Liquid Resistant Enclosure (Silicon Factory Installed Gasket)	
Unfinished	1590WUFL
Black Textured Powder Paint	1590WUFLBK

ACCESSORIES	
Recommended Torque: 75 ozf.in / 55 cN.m	
Black Textured Cover Screws (Pkg 50) [6-32 x 1/2" SS Type 304]	1590WMS100BK
Unfinished Cover Screws (Pkg 100) [6-32 x 1/2" Nickel Plated Screws]	1590WMS100
Standard Cover Screws	
Unfinished Cover Screws (Pkg 100) [6-32 x 1/2" Nickel Plated Screws]	1590MS100
Black Textured Cover Screws (Pkg 50) [6-32 x 1/2" SS Type 304]	1590MS100BK

B

B

A

A

SECTION C-C Side of Slot

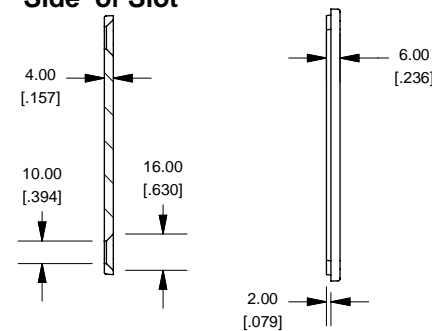

Lid

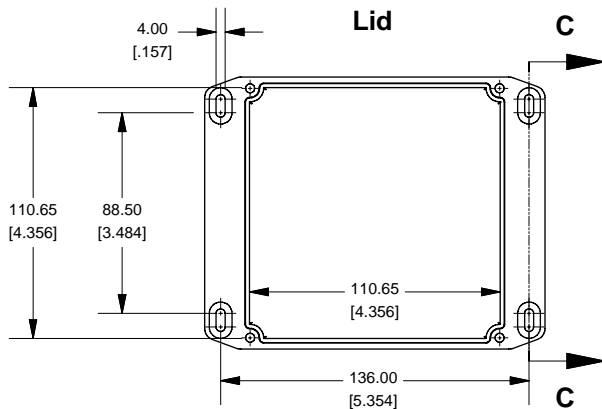

HAMMOND MANUFACTURING™
 1590UFL
www.hammondmfg.com